



SLOVENSKI STANDARD
SIST-TS CEN/TS 14918:2005

01-september-2005

HfXbUV]c[cf]j UË`A YrcXUnUi [cHj `Ub^Y_Ucf] bYj fYXbcgh

Solid Biofuels - Method for the determination of calorific value

Feste Biobrennstoffe - Verfahren Zur Bestimmung des Heizwertes

iTeh STANDARD PREVIEW

Biocombustibles solides - Méthode pour la détermination du pouvoir calorifique

Ta slovenski standard je istoveten z: **CEN/TS 14918:2005**
SIST-TS CEN/TS 14918:2005
<https://standards.iteh.ai/catalog/standards/sist/10264e9d-051e-4b7a-a2d8-846dc833d0d2/sist-ts-cen-ts-14918-2005>

ICS:

75.160.10 Trda goriva Solid fuels

SIST-TS CEN/TS 14918:2005 en

iTeh STANDARD PREVIEW
(standards.iteh.ai)

[SIST-TS CEN/TS 14918:2005](#)

<https://standards.iteh.ai/catalog/standards/sist/10264e9d-031e-4b7a-a2d8-846dc833d0d2/sist-ts-cen-ts-14918-2005>

TECHNICAL SPECIFICATION
SPÉCIFICATION TECHNIQUE
TECHNISCHE SPEZIFIKATION

CEN/TS 14918

May 2005

ICS 75.160.10

English version

Solid Biofuels - Method for the determination of calorific value

Biocombustibles solides - Méthode pour la détermination
du pouvoir calorifique

Feste Biobrennstoffe - Verfahren Zur Bestimmung des
Heizwertes

This Technical Specification (CEN/TS) was approved by CEN on 16 August 2004 for provisional application.

The period of validity of this CEN/TS is limited initially to three years. After two years the members of CEN will be requested to submit their comments, particularly on the question whether the CEN/TS can be converted into a European Standard.

CEN members are required to announce the existence of this CEN/TS in the same way as for an EN and to make the CEN/TS available promptly at national level in an appropriate form. It is permissible to keep conflicting national standards in force (in parallel to the CEN/TS) until the final decision about the possible conversion of the CEN/TS into an EN is reached.

CEN members are the national standards bodies of Austria, Belgium, Cyprus, Czech Republic, Denmark, Estonia, Finland, France, Germany, Greece, Hungary, Iceland, Ireland, Italy, Latvia, Lithuania, Luxembourg, Malta, Netherlands, Norway, Poland, Portugal, Slovakia, Slovenia, Spain, Sweden, Switzerland and United Kingdom.

(standards.iteh.ai)

SIST-TS CEN/TS 14918:2005

<https://standards.iteh.ai/catalog/standards/sist/10264e9d-031e-4b7a-a2d8-846dc833d0d2/sist-ts-cen-ts-14918-2005>



EUROPEAN COMMITTEE FOR STANDARDIZATION
COMITÉ EUROPÉEN DE NORMALISATION
EUROPÄISCHES KOMITEE FÜR NORMUNG

Management Centre: rue de Stassart, 36 B-1050 Brussels

Contents

	page
Contents	2
Foreword.....	3
1 Scope	5
2 Normative references	5
3 Terms and definitions	6
4 Principle.....	7
5 Reagents.....	7
6 Apparatus	8
7 Preparation of test sample.....	11
8 Calorimetric procedure	12
9 Calibration	18
10 Gross calorific value	24
11 Precision.....	28
12 Calculation of net calorific value at constant pressure.....	29
13 Test report	30
Annex A (normative) Adiabatic bomb calorimeters.....	32
Annex B (normative) Isoperibol and static-jacket bomb calorimeters.....	36
Annex C (normative) Automated bomb calorimeters	42
Annex D (informative) Checklists for the design and procedures of combustion experiments	45
Annex E (informative) Examples to illustrate the main calculations used in this Technical Specification when an automated (adiabatic) bomb calorimeter is used for determinations	50
Annex F (informative) List of symbols used in this Technical Specification	54
Annex G (informative) Key-word index	57
Annex H (informative) Default values of most used biofuels for the calculations of calorific values.....	61
Annex I (informative) Flow chart for a routine calorific value determination.....	62

iTech STANDARD PREVIEW
(standards.itech.ai)

[SIST-TS CEN/TS 14918:2005](https://standards.itech.ai/catalog/standards/sist/10264e9d-031e-4b7a-a2d8-8461e833d0d2/sist-ts-cen-ts-14918-2005)

<https://standards.itech.ai/catalog/standards/sist/10264e9d-031e-4b7a-a2d8-8461e833d0d2/sist-ts-cen-ts-14918-2005>

Foreword

This document (CEN/TS 14918:2005) has been prepared by Technical Committee CEN/TC 335 “Solid Biofuels”, the secretariat of which is held by SIS.

According to the CEN/CENELEC Internal Regulations, the national standards organizations of the following countries are bound to announce this CEN Technical Specification: Austria, Belgium, Cyprus, Czech Republic, Denmark, Estonia, Finland, France, Germany, Greece, Hungary, Iceland, Ireland, Italy, Latvia, Lithuania, Luxembourg, Malta, Netherlands, Norway, Poland, Portugal, Slovakia, Slovenia, Spain, Sweden, Switzerland and United Kingdom.

iTeh STANDARD PREVIEW (standards.iteh.ai)

[SIST-TS CEN/TS 14918:2005](https://standards.iteh.ai/catalog/standards/sist/10264e9d-031e-4b7a-a2d8-846dc833d0d2/sist-ts-cen-ts-14918-2005)

<https://standards.iteh.ai/catalog/standards/sist/10264e9d-031e-4b7a-a2d8-846dc833d0d2/sist-ts-cen-ts-14918-2005>

Introduction

WARNING - Strict adherence to all of the provisions prescribed in this Technical Specification should ensure against explosive rupture of the bomb, or a blow-out, provided that the bomb is of proper design and construction and in good mechanical condition.

iTeh STANDARD PREVIEW (standards.iteh.ai)

[SIST-TS CEN/TS 14918:2005](https://standards.iteh.ai/catalog/standards/sist/10264e9d-031e-4b7a-a2d8-846dc833d0d2/sist-ts-cen-ts-14918-2005)

<https://standards.iteh.ai/catalog/standards/sist/10264e9d-031e-4b7a-a2d8-846dc833d0d2/sist-ts-cen-ts-14918-2005>

1 Scope

This document specifies a method for the determination of the gross calorific value of a solid biofuel at constant volume and at the reference temperature 25 °C in a bomb calorimeter calibrated by combustion of certified benzoic acid.

The result obtained is the gross calorific value of the analysis sample at constant volume with all the water of the combustion products as liquid water. In practice, biofuels are burned at constant (atmospheric) pressure and the water is either not condensed (removed as vapour with the flue gases) or condensed. Under both conditions, the operative heat of combustion to be used is the net calorific value of the fuel at constant pressure. The net calorific value at constant volume may also be used; formulae are given for calculating both values.

General principles and procedures for the calibrations and the biofuel experiments are presented in the main text, whereas those pertaining to the use of a particular type of calorimetric instrument are described in Annexes A to C. Annex D contains checklists for performing calibration and fuel experiments using specified types of calorimeters. Annex E gives examples to illustrate some of the calculations.

2 Normative references

The following referenced documents are indispensable for the application of this document. For dated references, only the edition cited applies. For undated references, the latest edition of the referenced document (including any amendments) applies.

prCEN/TS 15234, *Solid biofuels – Fuel quality assurance*

[SIST-TS CEN/TS 14918:2005](#)

CEN/TS 14774-1:2004, *Solid biofuels – Methods for determination of moisture content – Oven dry method – Part 1: Total moisture – Reference method*

[10d2/sist-ts-cen-ts-14918-2005](#)

CEN/TS 14774-2, *Solid biofuels – Methods for determination of moisture content – Oven dry method – Part 2: Total moisture – Simplified method*

CEN/TS 14774-3, *Solid biofuels – Methods for determination of moisture content – Oven dry method – Part 3: Moisture in general analysis sample*

prCEN/TS 14780, *Solid biofuels – Methods of sample preparation*

prCEN/TS XXX¹, *Solid biofuels - Calculation of analyses to different bases*

00335026, *Solid biofuels –Determination of total content of sulfur and chlorine*

EN ISO 10304-1:1995 *Water quality – Determination of dissolved fluoride, chloride, nitrite, orthophosphate, bromide, nitrate, and sulfate ions, using liquid chromatography of ions – Part 1: Method for water with low contamination (ISO 10304-1:1992).*

ISO 651:1975, *Solid-stem calorimeter thermometers.*

ISO 652:1975, *Enclosed-scale calorimeter thermometers.*

ISO 1770:1981, *Solid-stem general purpose thermometers.*

1) Currently being worked on.

CEN/TS 14918:2005 (E)

ISO 1771:1981, *Enclosed-scale general purpose thermometers*.

3 Terms and definitions

For the purposes of this Technical Specification, the following terms and definitions apply.

3.1**gross calorific value at constant volume**

absolute value of the specific energy of combustion, in joules, for unit mass of a solid biofuel burned in oxygen in a calorimetric bomb under the conditions specified. The products of combustion are assumed to consist of gaseous oxygen, nitrogen, carbon dioxide and sulfur dioxide, of **liquid** water (in equilibrium with its vapour) saturated with carbon dioxide under the conditions of the bomb reaction, and of solid ash, all at the reference temperature

3.2**net calorific value at constant volume**

absolute value of the specific energy of combustion, in joules, for unit mass of the biofuel burned in oxygen under conditions of constant volume and such that all the water of the reaction products remains as water vapour (in a hypothetical state at 0,1 Mpa), the other products being as for the gross calorific value, all at the reference temperature

3.3**net calorific value at constant pressure**

absolute value of the specific heat (enthalpy) of combustion, in joules, for unit mass of the biofuel burned in oxygen at constant pressure under such conditions that all the water of the reaction products remains as water vapour (at 0,1 MPa), the other products being as for the gross calorific value, all at the reference temperature

3.4**reference temperature**

international reference temperature for thermochemistry of 25 °C is adopted as the reference temperature for calorific values (see 8.7)

SIST-TS CEN/TS 14918:2005

<https://standards.iteh.ai/catalog/standards/sist/10264e9d-031e-4b7a-a2d8-846cc655d0d2/sist-ts-cen-ts-14918-2005>

NOTE The temperature dependence of the calorific value of biofuels is small [less than 1 J/(g x K)].

3.5**effective heat capacity of the calorimeter**

amount of energy required to cause unit change in temperature of the calorimeter

3.6**corrected temperature rise**

change in calorimeter temperature caused solely by the processes taking place within the combustion bomb. It is the total observed temperature rise corrected for heat exchange, stirring power, etc. (8.6).

NOTE The change in temperature may be expressed in terms of other units: resistance of a platinum or thermistor thermometer, frequency of a quartz crystal resonator, etc., provided that a functional relationship is established between this quantity and a change in temperature. The effective heat capacity of the calorimeter may be expressed in units of energy per such an arbitrary unit. Criteria for the required linearity and closeness in conditions between calibrations and fuel experiments are given in 9.3.

A list of the symbols used and their definitions is given in Annex F

4 Principle

4.1 Gross calorific value

A weighed portion of the analysis sample of the solid biofuel is burned in high-pressure oxygen in a bomb calorimeter under specified conditions. The effective heat capacity of the calorimeter is determined in calibration experiments by combustion of certified benzoic acid under similar conditions, accounted for in the certificate. The corrected temperature rise is established from observations of temperature before, during and after the combustion reaction takes place. The duration and frequency of the temperature observations depend on the type of calorimeter used. Water is added to the bomb initially to give a saturated vapour phase prior to combustion (see 8.2.1 and 9.2.2), thereby allowing all the water formed, from the hydrogen and moisture in the sample, to be regarded as liquid water.

The gross calorific value is calculated from the corrected temperature rise and the effective heat capacity of the calorimeter, with allowances made for contributions from ignition energy, combustion of the fuse(s) and for thermal effects from side reactions such as the formation of nitric acid. Furthermore, a correction is applied to account for the difference in energy between the aqueous sulfuric acid formed in the bomb reaction and gaseous sulfur dioxide, i.e. the required reaction product of sulfur in the biofuel. The corresponding energy effect between aqueous and gaseous hydrochloric acid can be neglected due to the usually low chlorine content of most biofuels.

NOTE The typical chlorine content of solid biofuels is below 0,5 % (m/m) in dry matter.

4.2 Net calorific value

The net calorific value at constant volume and the net calorific value at constant pressure of the biofuel are obtained by calculation from the gross calorific value at constant volume determined on the analysis sample. The calculation of the net calorific value at constant volume requires information about the moisture and hydrogen contents of the analysis sample. In principle, the calculation of the net calorific value at constant pressure also requires information about the oxygen and nitrogen contents of the sample.

[SIST-TS CEN/TS 14918:2005](https://standards.iteh.ai/catalog/standards/sist/10264e9d-031e-4b7a-a2d8-846dc833d0d2/sist-ts-cen-ts-14918-2005)

<https://standards.iteh.ai/catalog/standards/sist/10264e9d-031e-4b7a-a2d8-846dc833d0d2/sist-ts-cen-ts-14918-2005>

5 Reagents

5.1 Oxygen, at a pressure high enough to fill the bomb to 3 MPa, pure with an assay of at least 99,5 % (V/V), and free from combustible matter.

NOTE Oxygen made by the electrolytic process may contain up to 4 % (V/V) of hydrogen.

5.2 Fuse

5.2.1 Ignition wire, of nickel-chromium 0,16 mm to 0,20 mm in diameter, platinum 0,05 mm to 0,10 mm in diameter, or another suitable conducting wire with well-characterized thermal behaviour during combustion.

5.2.2 Cotton fuse, of white cellulose cotton, or equivalent, if required (see Note 8 to 8.2.1).

5.3 Combustion aids of known gross calorific value, composition and purity, like benzoic acid, n-dodecane, paraffin oil, combustion bags or capsules may be used.

5.4 Standard volumetric solutions and indicators, only for use when analysis of final bomb solutions is required.

5.4.1 Barium hydroxide solution, $c[\text{Ba}(\text{OH})_2] = 0,05 \text{ mol/l}$.

5.4.2 Sodium carbonate solution, $c(\text{Na}_2\text{CO}_3) = 0,05 \text{ mol/l}$.

5.4.3 Sodium hydroxide solution, $c(\text{NaOH}) = 0,1 \text{ mol/l}$.

5.4.4 Hydrochloric acid solution, $c(\text{HCl}) = 0,1 \text{ mol/l}$.

CEN/TS 14918:2005 (E)**5.4.5 Screened methyl orange indicator**, 1 g/l solution.

Dissolve 0,25 g of methyl orange and 0,15 g of xylene cyanole FF in 50 ml of 95 % (V/V) ethanol and dilute to 250 ml with water.

5.4.6 Phenolphthalein, 10 g/l solution.

Dissolve 2,5 g of phenolphthalein in 250 ml of 95 % (V/V) ethanol.

5.5 Benzoic acid, of calorimetric-standard quality, certified by (or with certification unambiguously traceable to) a recognized standardizing authority.

NOTE Benzoic acid is the sole substance recommended for calibration of an oxygen-bomb calorimeter. For the purpose of checking the overall reliability of the calorimetric measurements, test substances, e.g. n-dodecane, are used. Test substances are mainly used to prove that certain characteristics of a sample, e.g. burning rate or chemical composition, do not introduce bias in the results. A test substance shall have a certified purity and a well-established energy of combustion.

The benzoic acid is burned in the form of pellets. It is normally used without drying or any treatment other than pelletizing; consult the sample certificate. It does not absorb moisture from the atmosphere at relative humidities below 90 %.

The benzoic acid shall be used as close to certification conditions as is feasible; significant departures from these conditions shall be accounted for in accordance with the directions in the certificate. The energy of combustion of the benzoic acid, as defined by the certificate for the conditions utilized, shall be adopted in calculating the effective heat capacity of the calorimeter (see 9.2).

TECHNICAL STANDARD PREVIEW
(standards.iteh.ai)

6 Apparatus**6.1 General**

<https://standards.iteh.ai/catalog/standards/sist/10264e9d-031e-4b7a-a2d8-846dc833d0d2/sist-ts-cen-ts-14918-2005>

The **calorimeter** (see Figure 1), consists of the assembled combustion bomb, the calorimeter can (with or without a lid), the calorimeter stirrer, water, temperature sensor, and leads with connectors inside the calorimeter can required for ignition of the sample or as part of temperature measurement or control circuits. During measurements the calorimeter is enclosed in a thermostat. The manner in which the thermostat temperature is controlled defines the working principle of the instrument and hence the strategy for evaluation of the corrected temperature rise.

In aneroid systems (systems without a fluid) the calorimeter can, stirrer and water are replaced by a metal block. The combustion bomb itself constitutes the calorimeter in some aneroid systems.

In combustion calorimetric instruments with a high degree of automation, especially in the evaluation of the results, the calorimeter is in a few cases not as well-defined as the traditional, classical-type calorimeter. Using such an automated calorimeter is, however, within the scope of this Technical Specification as long as the basic requirements are met with respect to calibration conditions, comparability between calibration and fuel experiments, ratio of sample mass to bomb volume, oxygen pressure, bomb liquid, reference temperature of the measurements and repeatability of the results. A print-out of some specified parameters from the individual measurements is essential. Details are given in Annex C.

As the room conditions (temperature fluctuation, ventilation etc.) may have an influence on the precision of the determination, the manufacturers instructions for the placing of the instrument shall always be followed.

Equipment, adequate for determinations of calorific value in accordance with this Technical Specification, is specified below.

6.2 Calorimeter with thermostat

6.2.1 Combustion bomb, capable of withstanding safely the pressures developed during combustion. The design shall permit complete recovery of all liquid products. The material of construction shall resist corrosion by the acids produced in the combustion of biofuels. A suitable internal volume of the bomb would be from 250 ml to 350 ml.

WARNING - Bomb parts shall be inspected regularly for wear and corrosion; particular attention shall be paid to the condition of the threads of the main closure. Manufacturers' instructions and any local regulations regarding the safe handling and use of the bomb shall be observed. When more than one bomb of the same design is used, it is imperative to use each bomb as a complete unit. Swapping of parts may lead to a serious accident.

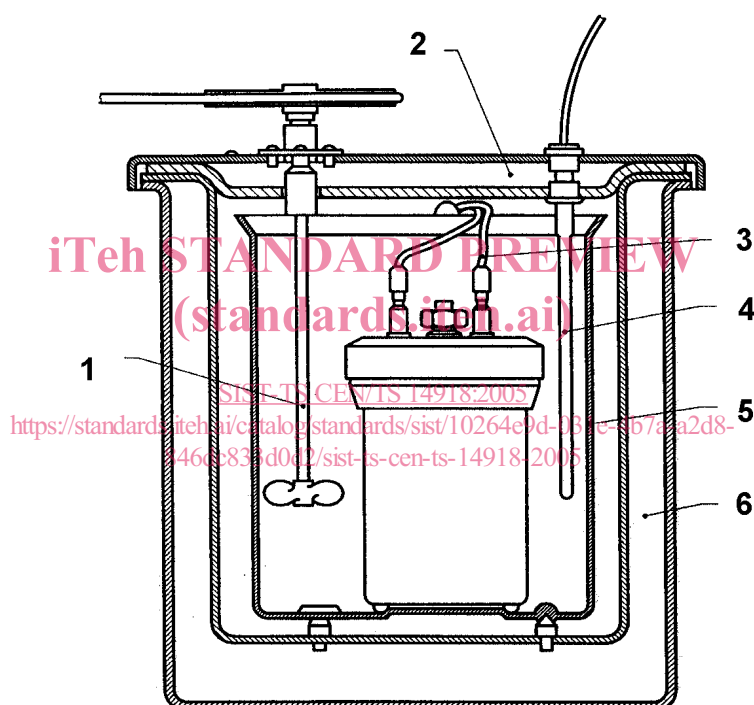

Key

1 Stirrer	4 Thermometer
2 Thermostat lid	5 Calorimeter can
3 Ignition leads	6 Thermostat

Figure 1 - Classical-type bomb combustion calorimeter with thermostat

6.2.2 Calorimeter can, made of metal, highly polished on the outside and capable of holding an amount of water sufficient to completely cover the flat upper surface of the bomb while the water is being stirred. A lid generally helps reduce evaporation of calorimeter water, but unless it is in good thermal contact with the can it

CEN/TS 14918:2005 (E)

lags behind in temperature during combustion, giving rise to undefined heat exchange with the thermostat and a prolonged main period.

6.2.3 Stirrer, working at constant speed. The stirrer shaft should have a low-heat-conduction and/or a low-mass section below the cover of the surrounding thermostat to minimize transmission of heat to or from the system; this is of particular importance when the stirrer shaft is in direct contact with the stirrer motor. When a lid is used for the calorimeter can, this section of the shaft should be above the lid.

NOTE The rate of stirring for a stirred-water type calorimeter should be large enough to make sure that hot spots do not develop during the rapid part of the change in temperature of the calorimeter. A rate of stirring such that the length of the main period can be limited to 10 min or less is usually adequate (see Annexes A and B).

6.2.4 Thermostat (water jacket), completely surrounding the calorimeter, with an air gap of approximately 10 mm separating calorimeter and thermostat.

The mass of water of a thermostat intended for isothermal operation shall be sufficiently large to outbalance thermal disturbances from the outside. The temperature should be controlled to within $\pm 0,1$ K or better throughout the experiment. A passive constant temperature ("static") thermostat shall have a heat capacity large enough to restrict the change in temperature of its water. Criteria for satisfactory behaviour of this type of water jacket are given in Annex B.

NOTE 1 For an insulated metal static jacket, satisfactory properties are usually ensured by making a wide annular jacket with a capacity for water of at least 12,5 l.

NOTE 2 Calorimeters surrounded by insulating material, creating a thermal barrier, are regarded as static-jacket calorimeters.

When the thermostat (water jacket) is required to follow closely the temperature of the calorimeter, it should be of low mass and preferably have immersion heaters. Energy shall be supplied at a rate sufficient to maintain the temperature of the water in the thermostat to within 0,1 K of that of the calorimeter water after the charge has been fired. When in a steady state at 25 °C, the calculated mean drift in temperature of the calorimeter shall not exceed 0,000 5 K/min (see A.3.2).

[SIST-TS CEN/TS 14918:2005](https://standards.iteh.ai/catalog/standards/sist/10264e9d-031e-4b7a-a2d8-100005002314-cen-ts-14918-2005)

[https://standards.iteh.ai/catalog/standards/sist/10264e9d-031e-4b7a-a2d8-](https://standards.iteh.ai/catalog/standards/sist/10264e9d-031e-4b7a-a2d8-100005002314-cen-ts-14918-2005)

6.2.5 Temperature measuring instrument, capable of indicating temperature with a resolution of at least 0,001 K so that temperature intervals of 2 K to 3 K can be determined with a resolution of 0,002 K or better. The absolute temperature shall be known to the nearest 0,1 K at the reference temperature of the calorimetric measurements. The temperature measuring device should be linear, or linearized, in its response to changes in temperature over the interval it is used.

As alternatives to the traditional mercury-in-glass thermometers, suitable temperature sensors are platinum resistance thermometers, thermistors, quartz crystal resonators, etc. which together with a suitable resistance bridge, null detector, frequency counter or other electronic equipment provide the required resolution. The short-term repeatability of this type of device shall be 0,001 K or better. Long-term drift shall not exceed the equivalent of 0,05 K for a period of six months. For sensors with linear response (in terms of temperature), drift is less likely to cause bias in the calorimetric measurements than are non-linear sensors.

Mercury-in-glass thermometers shall conform to ISO 651, ISO 652, ISO 1770 or ISO 1771. A viewer with magnification about 5× is needed for reading the temperature with the resolution required.

A mechanical vibrator to tap the thermometer is suitable for preventing the mercury column from sticking (see 8.4). If this is not available, the thermometer shall be tapped manually before reading the temperature.

6.2.6 Ignition circuit

The electrical supply shall be 6 V to 12 V alternating current from a step-down transformer or direct current from batteries. It is desirable to include a pilot light in the circuit to indicate when current is flowing.

Where the firing is done manually, the firing switch shall be of the spring-loaded, normally open type, located in such a manner that any undue risk to the operator is avoided (see warning in 8.4).

6.3 Crucible, of silica, nickel-chromium, platinum or similar unreactive material.

The crucible should be 15 - 25 mm in diameter, flat based and about 20 mm deep. Silica crucibles should be about 1,5 mm thick and metal crucibles about 0,5 mm thick.

If smears of unburned carbon occur, a small low-mass platinum or nickel-chromium crucible, for example 0,25 mm thick, 15 mm in diameter and 7 mm deep, may be used.

6.4 Ancillary pressure equipment

6.4.1 Pressure regulator, to control the filling of the bomb with oxygen.

6.4.2 Pressure gauge (e.g. 0 MPa to 5 MPa), to indicate the pressure in the bomb with a resolution of 0,05 MPa.

6.4.3 Relief valve or bursting disk, operating at 3,5 MPa, and installed in the filling line, to prevent overfilling the bomb.

CAUTION - Equipment for high-pressure oxygen shall be kept free from oil and grease (high vacuum grease recommended by the manufacturer can be used according to the operating manual of the instrument). Do not test or calibrate the pressure gauge with hydrocarbon fluid.

6.5 Timer, indicating minutes and seconds.

6.6 Balances

6.6.1 Balance for weighing the sample, fuse, etc., with a resolution of at least 0,1 mg; 0,01 mg is preferable and is recommended when the sample mass is of the order of 0,5 g or less (see 8.2.1).

6.6.2 Balance for weighing the calorimeter water, with a resolution of 0,5 g (unless water can be dispensed into the calorimeter by volume with the required accuracy, see 8.3).

6.7 Thermostat (optional), for equilibrating the calorimeter water before each experiment to a predetermined initial temperature, within about $\pm 0,3$ K.

6.8 Pellet press, capable of applying a force of about 10 tonnes, either hydraulically or mechanically, and having a die suitable to press a pellet having a diameter about 13 mm and a mass of $(1,0 \pm 0,1)$ g.

7 Preparation of test sample

The biofuel sample used for the determination of calorific value shall be the general analysis sample (ground to pass a test sieve with an aperture of 1,0 mm) prepared according to the procedure given in prCEN/TS 14780, Solid biofuels –Methods of sample preparation. Sieve with an aperture less than 1,0 mm (0,5 mm or 0,25 mm) might be necessary for many biofuels to ensure the requisite repeatability and a complete combustion.

Due to the low density of solid biofuels they shall be tested in a pellet form. A pellet of mass $(1 \pm 0,1)$ g is pressed with a suitable force to produce a compact, unbreakable test piece. Alternatively the test may be carried out in powder form, closed in a combustion bag or capsule.

The sample shall be well-mixed and in reasonable moisture equilibrium with the laboratory atmosphere. The moisture content shall either be determined simultaneously with the weighing of the samples for the determination of calorific value, or the sample shall be kept in a small, effectively closed container until moisture analyses are performed, to allow appropriate corrections for moisture in the analysis sample.

CEN/TS 14918:2005 (E)

Determination of the moisture content of the analysis sample shall be carried out by the method specified in CEN/TS 14774-3, Solid biofuels – Determination of moisture content – Oven dry method – Part 3: Moisture in general analysis sample.

8 Calorimetric procedure

8.1 General

The calorimetric determination consists of two separate experiments, combustion of the calibrant (benzoic acid) and combustion of the biofuel, both under same specified conditions. The calorimetric procedure for the two types of experiment is essentially the same. In fact, the overall similarity is a requirement for proper cancellation of systematic errors caused, for example, by uncontrolled heat leaks not accounted for in the evaluation of the corrected temperature rise θ .

The experiment consists of carrying out quantitatively a combustion reaction (in high-pressure oxygen in the bomb) to defined products of combustion and of measuring the change in temperature caused by the total bomb process.

The temperature measurements required for the evaluation of the corrected temperature rise θ are made during a fore period, a main (= reaction) period, and an after period as outlined in Figure 2. For the adiabatic type calorimeter, the fore and after periods need, in principle, be only as long as required to establish the initial (firing) and final temperatures, respectively (see Annex A). For the isoperibol (isothermal jacket) and the static-jacket type calorimeters, the fore and after periods serve to establish the heat exchange properties of the calorimeter required to allow proper correction for heat exchange between calorimeter and thermostat during the main period when combustion takes place. The fore and after periods then have to be longer; see Annex B.

The power of stirring shall be maintained constant throughout an experiment which calls for a constant rate of stirring. An excessive rate of stirring results in an undesirable increase in the power of stirring with ensuing difficulties in keeping it constant. A wobbling stirrer is likely to cause significant short-term variations in stirring power.

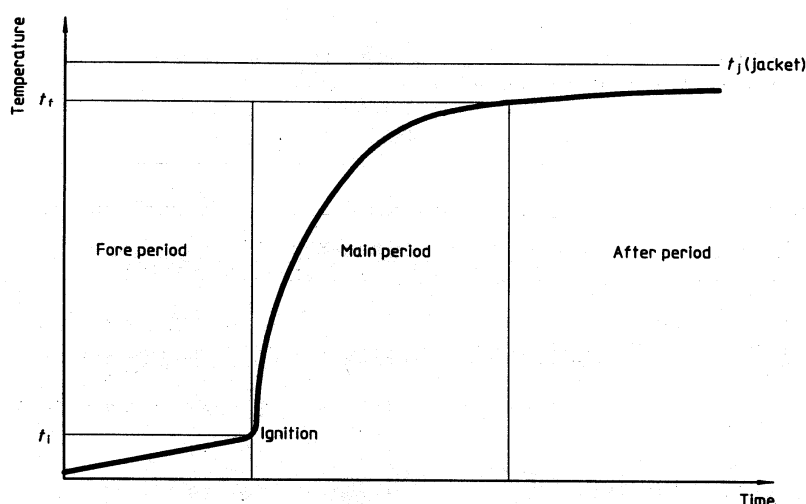

Figure 2 - Time-temperature curve (isoperibol calorimeter)

During combustion, the bomb head will become appreciably hotter than other parts of the bomb, and it is important to have enough well-stirred water above it to maintain reasonably small temperature gradients in the

calorimeter water during the rapid part of the rise in temperature. For aneroid systems, the particular design determines to what extent hot spots may develop (see Annex C).

Certain biofuels may persistently burn incompletely; “exploding” and/or leaving residues that contain significant amounts of unburned sample or soot. By adding known amounts of an auxiliary material (e.g. benzoic acid, n-dodecane or paraffin oil), by using bags or capsules or cotton fuse, or by omitting the distilled water from the bomb, or by using a lower oxygen filling pressure, a clean combustion can in most instances be achieved.

The auxiliary material shall be chemically stable, have known composition and purity, a low vapor pressure and a well-established energy of combustion; the energy should be known to within 0,10 % for particular material used. The amount used should be limited to the minimum amount required to achieve complete combustion of the sample. It should not exceed an amount that contributes half of the total energy in an experiment. The optimum proportion of the sample to auxiliary material depends on the properties of the fuel, and needs to be determined by experiment.

The mass of the auxiliary material shall be determined as accurately as possible so that its contribution can be correctly accounted for; this is particularly important when a hydrocarbon oil is used as its specific energy of combustion is considerably higher than that the biofuel.

8.2 Preparing the bomb for measurement

8.2.1 General procedure

Weigh the sample pellet, or the filled combustion bag or capsule, in the crucible, with a weighing resolution of 0,01 %, or better. For 1 g samples (see 9.2 and 10.2) this means weighing to the nearest 0,1 mg. Weigh the combustible fuse and/or ignition wire either with a precision comparable with that for weighing the sample, or keep its mass constant, within specified limits, for all experiments (see 9.4 and 9.6.1).

Fasten the ignition wire tautly between the electrodes in the bomb (see also NOTE). Check the resistance of the ignition circuit of the bomb; for most bombs it should not exceed 5 Ω to 10 Ω , measured between the outside connectors of the bomb head, or between the connector for the insulated electrode and the bomb head.

Tie, or attach firmly, the fuse (if needed, see NOTE) to the ignition wire, place the crucible in its support and bring the fuse into contact with the sample pellet or capsule. Make sure that the position of the crucible in the assembled bomb will be symmetrical with respect to the surrounding bomb wall.

NOTE When the ignition wire is combustible as well as electrically conducting, an alternative procedure may be adopted. A longer piece of wire, enough to make an open loop, is connected to the electrodes. After mounting of the crucible, the loop is brought in contact with the sample pellet or capsule. (In some cases the ignition process is better controlled when the wire is kept at a small distance above the sample pellet.) Care should be taken to prevent any contact between ignition wire and crucible, in particular when a metal crucible is used since this would result in shorting the ignition circuit. A special fuse is superfluous under these conditions. The resistance of the ignition circuit of the bomb will be increased by a small amount only. For closer details of preparing the bomb refer also manufacturers instructions.

Add a defined amount of distilled water to the bomb. The amount shall always be exactly the same both in calibration and in determinations (see 9.2.1 and 9.2.2). As a main principle for biofuels, (1,0 \pm 0,1) ml distilled water is added into the bomb. With some biofuels (and some calorimeters) the complete combustion can be achieved by omitting the distilled water out from the bomb or by using combustion aid. In some cases the total absorption of the gaseous combustion products might provide the use of a larger amount of distilled water (e.g. 5 ml).

Assemble the bomb and charge it slowly with oxygen to a pressure of (3,0 \pm 0,2) MPa without displacing the original air or, flush the bomb (with the outlet valve open, see manufacturers instructions) with oxygen for about 30 s, close slowly the valve and charge the bomb to the pressure of (3,0 \pm 0,2) MPa. The same procedure shall be used both in calibration and in determinations. If the bomb is inadvertently charged with oxygen above 3,3 MPa, discard the test and begin again.