**Thermal performance of buildings —
Transmission heat loss coefficient —
Calculation method**

*Performance thermique des bâtiments — Coefficient de déperdition par
transmission — Méthode de calcul*

iTeh STANDARD PREVIEW
(standards.iteh.ai)

ISO 13789:1999

<https://standards.iteh.ai/catalog/standards/sist/a7e3b52c-1703-4ccc-9551-24d4ced94cda/iso-13789-1999>



PDF disclaimer

This PDF file may contain embedded typefaces. In accordance with Adobe's licensing policy, this file may be printed or viewed but shall not be edited unless the typefaces which are embedded are licensed to and installed on the computer performing the editing. In downloading this file, parties accept therein the responsibility of not infringing Adobe's licensing policy. The ISO Central Secretariat accepts no liability in this area.

Adobe is a trademark of Adobe Systems Incorporated.

Details of the software products used to create this PDF file can be found in the General Info relative to the file; the PDF-creation parameters were optimized for printing. Every care has been taken to ensure that the file is suitable for use by ISO member bodies. In the unlikely event that a problem relating to it is found, please inform the Central Secretariat at the address given below.

iTeh STANDARD PREVIEW
(standards.iteh.ai)

ISO 13789:1999

<https://standards.iteh.ai/catalog/standards/sist/a7e3b52c-1703-4ccc-9551-24d4ced94cda/iso-13789-1999>

© ISO 1999

All rights reserved. Unless otherwise specified, no part of this publication may be reproduced or utilized in any form or by any means, electronic or mechanical, including photocopying and microfilm, without permission in writing from either ISO at the address below or ISO's member body in the country of the requester.

ISO copyright office
Case postale 56 • CH-1211 Geneva 20
Tel. + 41 22 749 01 11
Fax + 41 22 734 10 79
E-mail copyright@iso.ch
Web www.iso.ch

Printed in Switzerland

Foreword

ISO (the International Organization for Standardization) is a worldwide federation of national standards bodies (ISO member bodies). The work of preparing International Standards is normally carried out through ISO technical committees. Each member body interested in a subject for which a technical committee has been established has the right to be represented on that committee. International organizations, governmental and non-governmental, in liaison with ISO, also take part in the work. ISO collaborates closely with the International Electrotechnical Commission (IEC) on all matters of electrotechnical standardization.

International Standards are drafted in accordance with the rules given in the ISO/IEC Directives, Part 3.

Draft International Standards adopted by the technical committees are circulated to the member bodies for voting. Publication as an International Standard requires approval by at least 75 % of member bodies casting a vote.

Attention is drawn to the possibility that some of the elements of this International Standard may be the subject of patent rights. ISO shall not be held responsible for identifying any or all such patent rights.

International Standard ISO 13789 was prepared by the European Committee for Standardization (CEN) in collaboration with ISO Technical Committee TC 163, *Thermal insulation*, Subcommittee SC 2, *Calculation methods*, in accordance with the Agreement on technical cooperation between ISO and CEN (Vienna Agreement).

Throughout the text of this standard, read "...this European Standard..." to mean "...this International Standard...".

Annex A forms an integral part of this International Standard. Annex B is for information only.

[ISO 13789:1999](https://standards.iteh.ai/catalog/standards/sist/a7e3b52c-1703-4ccc-9551-24d4ced94cda/iso-13789-1999)

<https://standards.iteh.ai/catalog/standards/sist/a7e3b52c-1703-4ccc-9551-24d4ced94cda/iso-13789-1999>

Contents

Foreword	v
Introduction	v
1 Scope	1
2 Normative references	1
3 Definitions	1
4 Transmission heat loss coefficient.....	2
5 Additional conventions	5
6 Report.....	6
Annex A (normative) Temperature in unheated space.....	7
Annex B (informative) Information on type of dimensions.....	8

ITeH STANDARD PREVIEW
(standards.iteh.ai)
ISO 13789:1999
<https://standards.iteh.ai/catalog/standards/sist/a7e3b52c-1705-4ccc-9551-24d4ced94cda/iso-13789-1999>

Foreword

The text of EN ISO 13789:1999 has been prepared by Technical Committee CEN/TC 89 "Thermal performance of buildings and building components", the secretariat of which is held by SIS, in collaboration with Technical Committee ISO/TC 163 "Thermal insulation".

This European Standard shall be given the status of a national standard, either by publication of an identical text or by endorsement, at the latest by February 2000, and conflicting national standards shall be withdrawn at the latest by February 2000.

According to the CEN/CENELEC Internal Regulations, the national standards organizations of the following countries are bound to implement this European Standard: Austria, Belgium, Czech Republic, Denmark, Finland, France, Germany, Greece, Iceland, Ireland, Italy, Luxembourg, Netherlands, Norway, Portugal, Spain, Sweden, Switzerland and the United Kingdom.

This standard is one of a series of standards on calculation methods for the design and evaluation of the thermal performance of buildings and building components.

Introduction

iTeh STANDARD PREVIEW

The aims of this standard are:

(standards.iteh.ai)

- a) to clarify the international market through the harmonised definition of an intrinsic characteristic of buildings,
- b) to help in judging compliance with regulations,
- c) to provide input data for calculation of annual energy use for heating buildings.

The result of the calculation can be used as input for calculation of annual energy use and heating load of buildings, for expressing the thermal transmission characteristic of a building or for judging compliance with specifications expressed in terms of transmission heat loss coefficient. The use of the transmission heat loss coefficient as defined by this standard for sizing heating systems may require appreciable corrections.

iTeh STANDARD PREVIEW
(standards.iteh.ai)

ISO 13789:1999

<https://standards.iteh.ai/catalog/standards/sist/a7e3b52c-1703-4ccc-9551-24d4ced94cda/iso-13789-1999>

1 Scope

This standard specifies a method and provides conventions for the calculation of the transmission heat loss coefficient of whole buildings and parts of buildings. For the purpose of this standard, the heated space is assumed to be at uniform temperature.

Heat loss by ventilation is not within the scope of this standard. However, in order to evaluate transmission heat loss through unheated spaces, this standard gives conventional values of air change rates of such spaces.

Annex A provides a steady state method to calculate the temperature in unheated spaces adjacent to heated buildings.

2 Normative references

This standard incorporates by dated or undated reference, provisions from other publications. These normative references are cited at the appropriate places in the text and the publications are listed hereafter. For dated references, subsequent amendments to or revisions of any of these publications apply to this standard only when incorporated in it by amendment or revision. For undated references the latest edition of the publication referred to applies.

EN ISO 6946	Building components and building elements - Thermal resistance and thermal transmittance - Calculation method (ISO 6946)
EN ISO 7345	Thermal insulation - Physical quantities and definitions (ISO 7345)
EN ISO 10077-1 ¹⁾	Thermal performance of windows, doors and shutters - Calculation of thermal transmittance - Part 1: Simplified method (ISO 10077-1)
EN ISO 10211-1	Thermal bridges in building construction - Calculation of heat flows and surface temperatures - Part 1: General methods (ISO 10211-1)
EN ISO 10211-2 ¹⁾	Thermal bridges in building construction - Calculation of heat flows and surface temperatures - Part 2: Linear thermal bridges (ISO 10211-2)
EN ISO 13370	Thermal performance of buildings - Heat transfer via the ground - Calculation methods (ISO 13370)
EN ISO 14683	Thermal bridges in building construction - Linear thermal transmittance - Simplified methods and default values (ISO 14683)

3 Definitions

For the purposes of this standard, the definitions of EN ISO 7345 and those given below apply:

- 3.1 **heated space:** Room or enclosure which is heated at a given set-point temperature.
- 3.2 **transmission heat loss coefficient:** Heat flow rate from the heated space to the external environment by transmission divided by the temperature difference between internal and external environments.

NOTE Both temperatures being supposed uniform.

¹⁾ To be published.

- 3.3 **ventilation heat loss coefficient:** Heat flow rate from the heated space to the external environment by ventilation divided by the temperature difference between internal and external environments.
- 3.4 **heat loss coefficient:** Sum of transmission and ventilation heat loss coefficients.
- 3.5 **internal dimension:** Length measured from wall to wall and floor to ceiling inside each room of the building.
- 3.6 **overall internal dimension:** Length measured on the interior of the building, ignoring internal partitions.
- 3.7 **external dimension:** Length measured on the exterior of the building.

4 Transmission heat loss coefficient

4.1 Basic equation

The transmission heat loss coefficient, H_T , is calculated by:

$$H_T = L_D + L_s + H_U \quad (1)$$

where

- L_D is the direct coupling coefficient between the heated space and the exterior through the building envelope, defined by equation (2), in W/K;
- L_s is the steady state ground heat loss coefficient defined in 4.4, in W/K;
- H_U is the transmission heat loss coefficient through unheated spaces defined in equation (3), in W/K.

EN ISO 10211-1 gives a general procedure for the calculation of the total thermal coupling coefficient, L , of the complete envelope or any part of it, including ground loss. Where no unheated space is involved, it corresponds to the transmission heat loss coefficient as defined in this standard. EN ISO 10211-1 can then be used as an alternative or when a more accurate result is required.

4.2 Boundaries of heated space

Before calculation, the heated space of the building under consideration shall be clearly defined. The building elements to be considered in the calculations are the boundaries of the heated space.

The building envelope above ground is modelled by plane and beam-shaped elements as shown on figure 1.

Boundaries between the "underground" part, involving heat transmission through the ground, and the "above ground" part of the building, having direct loss to the external environment or loss to unheated spaces, are according to EN ISO 13370:

- for buildings with slab-on-ground floors, suspended floors and unheated basements: the level of the internal surface of the ground floor;
- for buildings with a heated basement: the external ground level.

Annex B provides information on the effect of using various types of dimensions when dividing the envelope into elements.

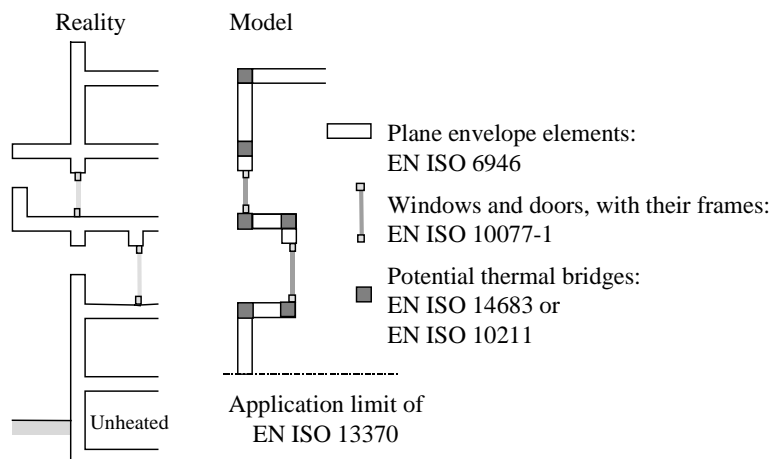

Figure 1 - Modelling the building envelope by plane and beam-shaped components

If calculations are performed for parts of buildings, the boundaries of these parts shall be clearly defined, so that the sum of the transmission heat loss coefficients of all parts equals that of the building.

4.3 Direct transmission to the exterior

The transmission heat loss coefficient through the building elements separating the heated space and the external air is calculated either by:

$$L_D = \sum_i A_i U_i + \sum_k l_k \Psi_k + \sum_j \chi_j \quad \text{or by} \quad L_D = \sum_i A_i U_i + \sum_k L_k^{2D} l_k + \sum_j L_j^{3D} \quad (2)$$

where

- A_i is the area of element i of the building envelope, in m^2 , (the dimensions of windows and doors are taken as the dimensions of the aperture in the wall);
- U_i is the thermal transmittance of element i of the building envelope, calculated according to EN ISO 6946 for opaque elements or according to EN ISO 10077-1 for glazed elements, in $\text{W}/(\text{m}^2 \cdot \text{K})$;
- l_k is the length of linear thermal bridge k , in m ;
- Ψ_k is the linear thermal transmittance of thermal bridge k , taken from EN ISO 14683 or calculated according to EN ISO 10211-2, in $\text{W}/(\text{m} \cdot \text{K})$;
- χ_j is the point thermal transmittance of point thermal bridge j , calculated according to EN ISO 10211-1, in W/K (point thermal bridges which are normally part of plane building elements and already taken into account in their thermal transmittance shall not be added here);
- L_k^{2D} is a thermal coupling coefficient, obtained from a two-dimensional calculation according to EN ISO 10211-1, in $\text{W}/(\text{m} \cdot \text{K})$;
- L_j^{3D} is a thermal coupling coefficient, obtained from a three-dimensional calculation according to EN ISO 10211-1, in W/K ;

The summation shall be done over all the building components separating the internal and the external environments.

For situations not covered by EN ISO 6946, EN ISO 10077-1, EN ISO 14683 or EN ISO 10211-2, EN ISO 10211-1 shall be referred to.