



# SLOVENSKI STANDARD

## SIST EN 859:2009

01-februar-2009

Nadomešča:  
SIST EN 859:2000

---

### Varnost lesnoobdelovalnih strojev - Skobeljni stroji z ročnim podajanjem

Safety of woodworking machines - Hand fed surface planing machines

Sicherheit von Holzbearbeitungsmaschinen - Abrichthobelmaschinen mit Handvorschub

Sécurité des machines pour le travail du bois - Machines à dégauchir à avance manuelle  
**iTeh STANDARD PREVIEW**  
**(standards.iteh.ai)**

Ta slovenski standard je istoveten z: ~~SIST EN 859:2009~~ **EN 859:2007**

<https://standards.iteh.ai/catalog/standards/sist/4dbf5810-afc7-48a0-9767-e9d0177a23ee/sist-en-859-2009>

---

#### **ICS:**

|           |                               |                      |
|-----------|-------------------------------|----------------------|
| 25.080.25 | Stroji za ploščinsko obdelavo | Planing machines     |
| 79.120.10 | Lesnoobdelovalni stroji       | Woodworking machines |

**SIST EN 859:2009**

**en**

**iTeh STANDARD PREVIEW**  
**(standards.iteh.ai)**

SIST EN 859:2009

<https://standards.iteh.ai/catalog/standards/sist/4dbf5810-afc7-48a0-9767-e9d0177a23ce/sist-en-859-2009>

EUROPEAN STANDARD  
NORME EUROPÉENNE  
EUROPÄISCHE NORM

**EN 859**

June 2007

ICS 79.120.10

Supersedes EN 859:1997

English Version

## Safety of woodworking machines - Hand fed surface planing machines

Sécurité des machines pour le travail du bois - Machines à dégauchir à avance manuelle

Sicherheit von Holzbearbeitungsmaschinen - Abrichtobelmaschinen mit Handvorschub

This European Standard was approved by CEN on 10 May 2007.

CEN members are bound to comply with the CEN/CENELEC Internal Regulations which stipulate the conditions for giving this European Standard the status of a national standard without any alteration. Up-to-date lists and bibliographical references concerning such national standards may be obtained on application to the CEN Management Centre or to any CEN member.

This European Standard exists in three official versions (English, French, German). A version in any other language made by translation under the responsibility of a CEN member into its own language and notified to the CEN Management Centre has the same status as the official versions.

CEN members are the national standards bodies of Austria, Belgium, Bulgaria, Cyprus, Czech Republic, Denmark, Estonia, Finland, France, Germany, Greece, Hungary, Iceland, Ireland, Italy, Latvia, Lithuania, Luxembourg, Malta, Netherlands, Norway, Poland, Portugal, Romania, Slovakia, Slovenia, Spain, Sweden, Switzerland and United Kingdom.

[SIST EN 859:2009](https://standards.iteh.ai/catalog/standards/sist/4dbf5810-afc7-48a0-9767-e9d0177a23ce/sist-en-859-2009)

<https://standards.iteh.ai/catalog/standards/sist/4dbf5810-afc7-48a0-9767-e9d0177a23ce/sist-en-859-2009>



EUROPEAN COMMITTEE FOR STANDARDIZATION  
COMITÉ EUROPÉEN DE NORMALISATION  
EUROPÄISCHES KOMITEE FÜR NORMUNG

Management Centre: rue de Stassart, 36 B-1050 Brussels

## Contents

Page

|  |           |
|--|-----------|
| Foreword.....  | 4         |
| Introduction .....   | 5         |
| <b>1</b> <b>Scope</b> .....  | <b>6</b>  |
| <b>2</b> <b>Normative references</b> .....   | <b>6</b>  |
| <b>3</b> <b>Terms and definitions</b> .....  | <b>8</b>  |
| 3.1 <b>General</b> .....   | 8         |
| 3.2 <b>Definitions</b> .....   | 8         |
| 3.3 <b>Terms</b> .....   | 10        |
| <b>4</b> <b>List of significant hazards</b> .....  | <b>12</b> |
| <b>5</b> <b>Safety requirements and/or measures</b> .....                                  | <b>14</b> |
| 5.1 <b>General</b> .....   | 14        |
| 5.2 <b>Controls</b> .....  | 14        |
| 5.2.1 <b>Safety and reliability of control systems</b> .....                               | 14        |
| 5.2.2 <b>Position of controls</b> .....  | 15        |
| 5.2.3 <b>Starting</b> .....  | 16        |
| 5.2.4 <b>Normal stopping</b> .....   | 17        |
| 5.2.5 <b>Emergency stop</b> .....  | 17        |
| 5.2.6 <b>Failure of the power supply</b> .....   | 18        |
| 5.2.7 <b>Failure of the control circuit</b> .....  | 18        |
| 5.3 <b>Protection against mechanical hazards</b> .....                                     | 18        |
| 5.3.1 <b>Stability</b> .....   | 18        |
| 5.3.2 <b>Hazard of break up during operation</b> .....                                     | 19        |
| 5.3.3 <b>Cutterblock holder and cutterblock design</b> .....                               | 19        |
| 5.3.4 <b>Braking</b> .....   | 19        |
| 5.3.5 <b>Work piece supports and guides</b> .....  | 20        |
| 5.3.6 <b>Prevention of access to moving parts</b> .....                                    | 23        |
| 5.3.7 <b>Characteristics of guards</b> .....   | 28        |
| 5.3.8 <b>Safety appliances</b> .....   | 28        |
| 5.4 <b>Protection against non-mechanical hazards</b> .....                                 | 29        |
| 5.4.1 <b>Fire</b> .....  | 29        |
| 5.4.2 <b>Noise</b> .....   | 29        |
| 5.4.3 <b>Emission of chips and dust</b> .....  | 30        |
| 5.4.4 <b>Electricity</b> .....   | 31        |
| 5.4.5 <b>Ergonomics and handling</b> .....   | 31        |
| 5.4.6 <b>Pneumatics</b> .....  | 32        |
| 5.4.7 <b>Hydraulics</b> .....  | 32        |
| 5.4.8 <b>Electromagnetic compatibility</b> .....   | 32        |
| 5.4.9 <b>Supply disconnection (isolation)</b> .....  | 32        |
| 5.4.10 <b>Static electricity</b> .....   | 33        |
| 5.4.11 <b>Maintenance</b> .....  | 33        |
| <b>6</b> <b>Information for use</b> .....  | <b>33</b> |
| 6.1 <b>General</b> .....   | 33        |
| 6.2 <b>Marking</b> .....   | 33        |
| 6.3 <b>Instruction handbook</b> .....  | 34        |
| <b>Annex A (normative) Tests for bridge type guards for surface planing machines</b> ..... | <b>37</b> |
| A.1 <b>General</b> .....   | 37        |
| A.2 <b>Compression test</b> .....  | 37        |
| A.3 <b>Shock test</b> .....  | 37        |

|                     |  |           |
|---------------------|--|-----------|
| <b>A.4</b>          | <b>Strength test</b> .....   | <b>37</b> |
| <b>Annex B</b>      | <b>(normative) Table lip resistance test</b> .....   | <b>39</b> |
| <b>B.1</b>          | <b>General</b> .....   | <b>39</b> |
| <b>B.2</b>          | <b>Work piece</b> .....  | <b>39</b> |
| <b>B.3</b>          | <b>Measurements</b> .....  | <b>41</b> |
| <b>B.4</b>          | <b>Test</b> .....  | <b>42</b> |
| <b>B.5</b>          | <b>Result</b> .....  | <b>43</b> |
| <b>Annex C</b>      | <b>(normative) Stability test for displaceable machines</b> .....  | <b>44</b> |
| <b>Annex D</b>      | <b>(normative) Impact test method for guards</b> .....   | <b>45</b> |
| <b>D.1</b>          | <b>General</b> .....   | <b>45</b> |
| <b>D.2</b>          | <b>Test method</b> .....   | <b>45</b> |
| <b>D.2.1</b>        | <b>Preliminary remarks</b> .....   | <b>45</b> |
| <b>D.2.2</b>        | <b>Testing equipment</b> .....   | <b>45</b> |
| <b>D.2.3</b>        | <b>Projectile for guards</b> .....   | <b>45</b> |
| <b>D.2.4</b>        | <b>Sampling</b> .....  | <b>45</b> |
| <b>D.2.5</b>        | <b>Test procedure</b> .....  | <b>45</b> |
| <b>D.3</b>          | <b>Results</b> .....   | <b>46</b> |
| <b>D.4</b>          | <b>Assessment</b> .....  | <b>46</b> |
| <b>D.5</b>          | <b>Test report</b> .....   | <b>46</b> |
| <b>D.6</b>          | <b>Test equipment for impact test</b> .....  | <b>46</b> |
| <b>Annex E</b>      | <b>(informative) Use of well tried components</b> .....  | <b>48</b> |
| <b>Annex F</b>      | <b>(normative) Use of electronic components</b> .....  | <b>49</b> |
| <b>F.1</b>          | <b>General</b> .....   | <b>49</b> |
| <b>F.2</b>          | <b>SRECS design</b> .....  | <b>49</b> |
| <b>F.2.1</b>        | <b>Components, hardware</b> .....  | <b>49</b> |
| <b>F.2.2</b>        | <b>Safety related software</b> .....   | <b>50</b> |
| <b>Annex G</b>      | <b>(normative) Braking tests</b> .....   | <b>52</b> |
| <b>G.1</b>          | <b>Conditions for all tests</b> .....  | <b>52</b> |
| <b>G.2</b>          | <b>Unbraked run-down time</b> .....  | <b>52</b> |
| <b>G.3</b>          | <b>Braked run-down time</b> .....  | <b>52</b> |
| <b>Annex ZA</b>     | <b>(informative) Relationship between this European Standard and the Essential Requirements of EU Directive 98/37/EC</b> ..... | <b>53</b> |
| <b>Bibliography</b> | .....  | <b>56</b> |

**EN 859:2007 (E)****Foreword**

This document (EN 859:2007) has been prepared by Technical Committee CEN/TC 142 "Woodworking machines - Safety", the secretariat of which is held by UNI.

This European Standard shall be given the status of a national standard, either by publication of an identical text or by endorsement, at the latest by December 2007, and conflicting national standards shall be withdrawn at the latest by December 2008.

This document supersedes EN 859:1997.

This document has been prepared under a mandate given to CEN by the European Commission and the European Free Trade Association, and supports essential requirements of the Machinery Directive.

For relationship with EU Directive, see informative Annex ZA, which is an integral part of this document.

Organisation contributing to the preparation of this document include the European Association of Manufacturer of Woodworking Machines "EUMABOIS".

The European Standards produced by CEN/TC 142 are particular to woodworking machines and complement the relevant A and B standards on the subject of general safety (see introduction of EN ISO 12100-1:2003 for a description of A, B and C standards).

According to the CEN/CENELEC Internal Regulations, the national standards organizations of the following countries are bound to implement this European Standard: Austria, Belgium, Bulgaria, Cyprus, Czech Republic, Denmark, Estonia, Finland, France, Germany, Greece, Hungary, Iceland, Ireland, Italy, Latvia, Lithuania, Luxembourg, Malta, Netherlands, Norway, Poland, Portugal, Romania, Slovakia, Slovenia, Spain, Sweden, Switzerland and United Kingdom.

## Introduction

This document has been prepared to be a harmonised standard to provide one means of conforming to the essential safety requirements of the Machinery Directive, and associated EFTA regulations.

This document is a type C standard as stated in EN ISO 12100-1:2003.

The machinery concerned and the extent to which hazards, hazardous situations and events are covered are indicated in the scope of this document.

When provisions of this type C standard are different from those which are stated in type A or B standards, the provisions of this type C standard take precedence over the provisions of other standards, for machines that have been designed and built according to the provisions of this type C standard.

The requirements of this document are directed to manufacturers and their authorised representatives of hand fed surface planing machines. They are also useful for designers and importers.

This document also includes examples of provisions and examples of information to be provided by the manufacturer to the user.

Common requirements for tooling are given in EN 847-1:2005.

ITIH STANDARD PREVIEW  
(standards.iteh.ai)

SIST EN 859:2009

<https://standards.iteh.ai/catalog/standards/sist/4dbf5810-afc7-48a0-9767-e9d0177a23ce/sist-en-859-2009>

## EN 859:2007 (E)

## 1 Scope

This document deals with the significant hazards, hazardous situation and events as listed in Clause 4 relevant to stationary and displaceable hand fed surface planing machines fitted or not with demountable power feed unit hereinafter referred to as "machines" designed to cut solid wood, chipboard, fibreboard and plywood when they are used as intended and under the conditions foreseen by the manufacturer.

This document does not apply to:

- a) machines set up on a bench or a table similar to a bench, which is intended to carry out work in a stationary position, capable of being lifted by one person by hand;

NOTE 1 Transportable motor-operated electric tools are dealt with by EN 61029-1:2000 together with prEN 61029-2-3:2004.

- b) hand held planers or any adaptation permitting their use in a different mode, i.e. bench mounting.

NOTE 2 Hand-held motor-operated electric tools are dealt with by EN 60745-1:2006 together with EN 60745-2-14:2003.

This document is not applicable to hand fed surface planing machines which are manufactured before the date of its publication as EN.

NOTE 3 Machines covered by this document are listed under A.2 of Annex IV of the Machinery Directive.

## iTeh STANDARD PREVIEW (standards.iteh.ai)

## 2 Normative references

The following referenced documents are indispensable for the application of this document. For dated references, only the edition cited applies. For undated references, the latest edition of the referenced document (including any amendments) applies.

EN 294:1992, *Safety of machinery — Safety distance to prevent danger zones being reached by the upper limbs*

EN 847-1:2005, *Tools for woodworking — Safety requirements — Part 1: Milling tools, circular saw blades*

EN 982:1996, *Safety of machinery — Safety requirements for fluid power systems and their components — Hydraulics*

EN 983:1996, *Safety of machinery — Safety requirements for fluid power systems and their components — Pneumatics*

EN 1005-2:2003, *Safety of machinery — Human physical performance — Part 2: Manual handling of machinery and component parts of machinery*

EN 1005-4:2005, *Safety of machinery — Human physical performance — Part 4: Evaluation of working postures and movements in relation to machinery*

EN 1037:1995, *Safety of machinery — Prevention of unexpected start-up*

EN 50178:1997, *Electronic equipment for use in power installations*

EN 50370-1:2005, *Electromagnetic compatibility (EMC) — Product family standard for machine tools — Part 1: Emission*

EN 50370-2:2003, *Electromagnetic compatibility (EMC) — Product family standard for machine tools — Part 2: Immunity*



- EN 60204-1:2006, *Safety of machinery — Electrical equipment of machines — Part 1: General requirements (IEC 60204-1:2005, modified)*
- EN 60439-1:1999, *Low-voltage switchgear and controlgear assemblies — Part 1: Type-tested and partially type-tested assemblies (IEC 60439-1:1999)*
- EN 60529:1991, *Degrees of protection provided by enclosures (IP code) (IEC 60529:1989)*
- EN 61496-1:2004, *Safety of machinery — Electro-sensitive protective equipment — Part 1: General requirements and tests (IEC 61496-1:2004, modified)*
- EN 61508-3:2001, *Functional safety of electrical/electronic/programmable electronic safety-related systems — Part 3: Software requirements (IEC 61508-3:1998 + Corrigendum 1999)*
- EN 62061:2005, *Safety of machinery — Functional safety of safety-related electrical, electronic and programmable electronic control systems (IEC 62061:2005)*
- EN ISO 3743-1:1995, *Acoustics — Determination of sound power levels of noise sources — Engineering methods for small, movable sources in reverberant fields — Part 1: Comparison method for hard-walled test rooms (ISO 3743-1:1994)*
- EN ISO 3743-2:1996, *Acoustics — Determination of sound power levels of noise sources using sound pressure — Engineering methods for small, movable sources in reverberant fields — Part 2: Methods for special reverberation test rooms (ISO 3743-2:1994)*
- EN ISO 3744:1995, *Acoustics — Determination of sound power levels of noise sources using sound pressure — Engineering method in an essentially free field over a reflecting plane (ISO 3744:1994)*
- EN ISO 3745:2003, *Acoustics — Determination of sound power levels of noise sources using sound pressure — Precision methods for anechoic and semi-anechoic rooms (ISO 3745:2003)*
- EN ISO 3746:1995, *Acoustics — Determination of sound power levels of noise sources using sound pressure — Survey method using an enveloping measurement surface over a reflecting plane (ISO 3746:1995)*
- EN ISO 4871:1996, *Acoustics — Declaration and verification of noise emission values of machinery and equipment (ISO 4871:1996)*
- EN ISO 9614-1:1995, *Acoustics — Determination of sound power levels of noise sources using sound intensity — Part 1: Measurement at discreet points (ISO 9614-1:1993)*
- EN ISO 11202:1995, *Acoustics — Noise emitted by machinery and equipment — Measurement of emission sound pressure levels at the work station and at other specified positions — Survey method in situ (ISO 11202:1995)*
- EN ISO 11204:1995, *Acoustics — Noise emitted by machinery and equipment — Measurement of emission sound pressure levels at a work station and at other specified positions — Method requiring environmental corrections (ISO 11204:1995)*
- EN ISO 11688-1:1998, *Acoustics — Recommended practice for the design of low-noise machinery and equipment — Part 1: Planning (ISO/TR 11688-1:1995)*
- EN ISO 12100-1:2003, *Safety of machinery — Basic concepts, general principles for design — Part 1: Basic terminology, methodology (ISO 12100-1:2003)*
- EN ISO 12100-2:2003, *Safety of machinery — Basic concepts, general principles for design — Part 2: Technical principles (ISO 12100-2:2003)*

**EN 859:2007 (E)**

EN ISO 13849-1:2006<sup>1)</sup>, *Safety of machinery — Safety-related parts of controls systems — Part 1: General principles for design (ISO 13849-1:2006)*

EN ISO 13849-2:2003, *Safety of machinery — Safety-related parts of control systems — Part 2: Validation (ISO 13849-2:2003)*

HD 22.4 S4:2004, *Cables of rated voltages up to and including 450/750 V and having crosslinked insulation — Part 4: Cords and flexible cables*

ISO 7571:1986, *Woodworking machines — Surface planing machines with cutterblock for one-side dressing — Nomenclature and acceptance conditions*

ISO 7960:1995, *Airborne noise emitted by machine tools — Operating conditions for woodworking machines*

**3 Terms and definitions****3.1 General**

For the purposes of this document, the terms and definitions given in EN ISO 12100-1:2003 and the following apply:

**3.2 Definitions****3.2.1****handfed surface planing machine**

machine designed for cutting off layers of the lower surface of a work piece by a cutterblock rotating around a horizontal axis, mounted at right angles to the infeed direction between two tables designed to position and support the work piece

NOTE The cutterblock is a cylindrical shaped complex tool equipped with blades with horizontal straight cutting line that cuts while rotating (see also for a description of the complex tool EN 847-1:2005). The work piece is fed into the machine against the direction of the cut

**3.2.2****hand feed**

manual holding and/or guiding of the work-piece. Hand feed includes the use of a demountable power feed unit

**3.2.3****stationary machine**

machine designed to be located on or fixed to the floor or other parts of the structure of the premises and to be stationary during use

**3.2.4****displaceable machine**

machine which is located on the floor, stationary during use and equipped with a device, normally wheels, which allows it to be moved between locations

**3.2.5****demountable power feed unit**

feed mechanism which is mounted on the machine so that it can be moved from its working position without the use of a spanner or similar additional device

<sup>1)</sup> Superseded EN 954-1:1996.

**3.2.6****kickback**

particular form of ejection describing the uncontrolled movement of the work piece or parts of it opposite to the direction of feed during processing

**3.2.7****run-down time**

elapsed time from the actuation of the stop control device to cutterblock stand still

**3.2.8****run-up time**

elapsed time from the actuation of the start control device until the spindle reaches the actual speed related to the intended speed

**3.2.9****operator position**

position in which the operator feeds the machine with the work piece

**3.2.10****machine actuator**

power mechanism used to effect motion of the machine

**3.2.11****safety programmable logic controller (PLC)**

programmable logic controller dedicated to safety related application designed in the required category according to EN ISO 13849-1:2006

**3.2.12****safety related electrical control system (SRECS)**

electrical part of a control system whose failure can result in an immediate increase of the risk(s)

[3.2.4 of EN 62061:2005]

**3.2.13****embedded software**

software that is part of the system supplied by the manufacturer that is not normally accessible for modification

NOTE 1 Firmware or system software are examples of embedded software (3.2.47 of EN 62061:2005).

NOTE 2 Manufacturer means manufacturer of the system.

NOTE 3 For example, the operating system of a speed monitoring device.

**3.2.14****application software**

software specific to the application that is specifically implemented by the designer of the SRECS generally containing logic sequences, limits and expressions that control the appropriate inputs, outputs, calculations and decisions necessary to meet SRECS functional requirements

[3.2.46 of EN 62061:2005]

NOTE For example, the PLC program to run a machine.

**3.2.15****safety related part of a control system (SRP(CS))**

part or subpart(s) of a control system that responds to input signals and generates safety-related output signals

**EN 859:2007 (E)**

NOTE The combined safety-related parts of a control system start at the point where the safety-related signals are initiated (including e.g. the actuating cam and the roller of the position switch) and end at the output of the power control elements (including e.g. the main contacts of the contactor). This also includes monitoring systems (3.1 of EN ISO 13849-1:2006)

**3.2.16****information from the supplier**

statement, sales literature, leaflets or other documents, where a manufacturer (or supplier) declares either the characteristics or the compliance of the material or product to a relevant standard

**3.3 Terms**

The names of the main parts of the machine are shown in Figure 1. Working operations when using the machine in the surfacing mode are shown in Figure 2.

## iTeh STANDARD PREVIEW (standards.iteh.ai)

[SIST EN 859:2009](https://standards.iteh.ai/catalog/standards/sist/4dbf5810-afc7-48a0-9767-e9d0177a23ce/sist-en-859-2009)

<https://standards.iteh.ai/catalog/standards/sist/4dbf5810-afc7-48a0-9767-e9d0177a23ce/sist-en-859-2009>

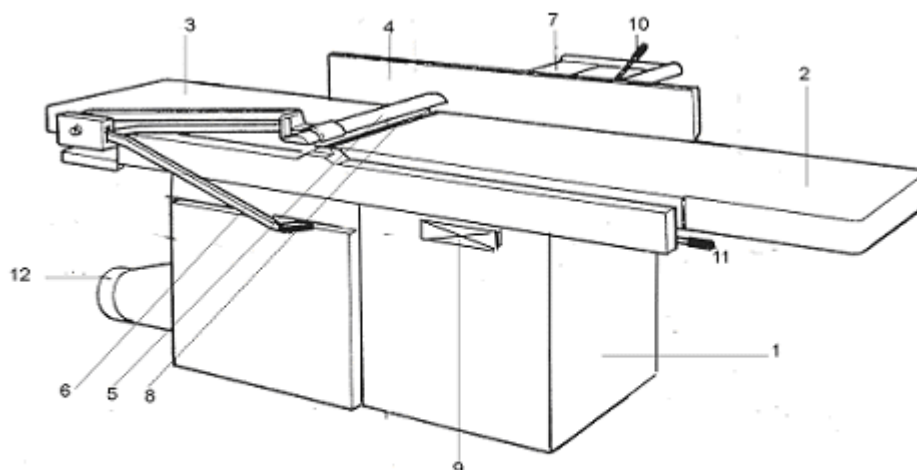
**Key**

- 1 main frame
- 2 infeed table
- 3 outfeed table
- 4 tiltable fence
- 5 bridge guard
- 6 bridge guard adjustment
- 7 guard rear the fence
- 8 cutterblock
- 9 controls
- 10 fence tilting adjustment
- 11 table height adjustment
- 12 dust extraction outlet

**iTeh STANDARD PREVIEW**  
**(standards.iteh.ai)**

[SIST EN 859:2009](https://standards.iteh.ai/catalog/standards/sist/4dbf5810-afc7-48a0-9767-e9d0177a23ce/sist-en-859-2009)

<https://standards.iteh.ai/catalog/standards/sist/4dbf5810-afc7-48a0-9767-e9d0177a23ce/sist-en-859-2009>

**Figure 1 — Example of hand fed surface planing machine**

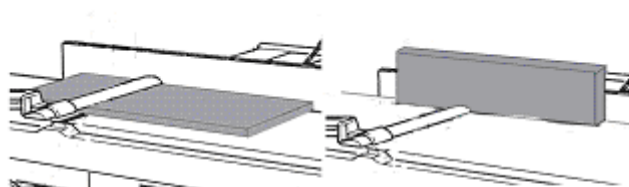

**Figure 2 — Planing (left) and edging (right)**

#### 4 List of significant hazards

This clause contains the significant hazards, hazardous situations and events (see EN 1050:1996), as far as they are dealt with in this document, identified by risk assessment as significant for the machines as defined in the scope and which require action to eliminate or reduce the risk. This document deals with these significant hazards by defining safety requirements and / or measures or by reference to relevant standards.

These hazards are listed in Table 1 in accordance with Annex A of EN 1050:1996.

**Table 1 — List of significant hazards**

| No                     | Hazards, hazardous situations and hazardous events   | EN ISO 12100 |                    | Relevant clause of this document |
|------------------------|--|--------------|--------------------|----------------------------------|
|                        |  | Part 1: 2003 | Part 2: 2003       |                                  |
| <b>1</b>               | <b>Mechanical hazards</b> related to:<br>- machine parts or work pieces due to:                  |              |                    |                                  |
|                        | a) shape;  | 4.2          | 4.2.1,<br>4.2.2, 5 | 5.3.3, 5.3.5,<br>5.3.6           |
|                        | b) relative location;  |              |                    | 5.2.2, 5.3.5,<br>5.3.6           |
|                        | c) mass and stability (potential energy of elements which may move under the effect of gravity); |              |                    | 5.3.1, 5.3.5                     |
|                        | e) mechanical strength;  |              |                    | 5.3.5, 5.3.6,<br>5.3.7           |
|                        | - accumulation of energy inside the machinery by:  |              |                    |                                  |
|                        | f) elastic elements (springs);   | 4.2          | 4.10,<br>5.5.4     | 5.3.6                            |
|                        | g) liquids and gases under pressure.   |              |                    | 5.4.6, 5.4.7                     |
| 1.1                    | Crushing hazard  | 4.2.1        |                    | 5.3.7                            |
| 1.3                    | Cutting or severing hazard   |              |                    | 5.3.3, 5.3.7                     |
| 1.4                    | Entanglement hazard  |              |                    | 5.3.7                            |
| 1.5                    | Drawing-in or trapping hazard  |              |                    | 5.3.7                            |
| 1.6                    | Impact hazard  |              |                    | 5.3.5                            |
| 1.9                    | High pressure fluid injection or ejection hazard   |              |                    | 5.4.6, 5.4.7                     |
| <b>2</b>               | <b>Electrical hazards</b> due to:  |              |                    |                                  |
| 2.1                    | Contact of persons with live parts (direct contact)  | 4.3          | 4.9,<br>5.5.4      | 5.4.4                            |
| 2.2                    | Contact of persons with parts which have become live under faulty conditions (indirect contact)  | 4.3          | 4.9                | 5.4.4                            |
| <i>to be continued</i> |  |              |                    |                                  |

Table 1 — List of significant hazards (continued)

| No                     | Hazards, hazardous situations and hazardous events  | EN ISO 12100 |                                   | Relevant clause of this document             |
|------------------------|---|--------------|-----------------------------------|--|
|                        |   | Part 1: 2003 | Part 2: 2003                      |  |
| <b>4</b>               | <b>Hazards generated by noise</b> , resulting in:   |              |                                   |  |
| 4.1                    | Hearing loss (deafness), other physiological disorders (loss of balance, loss of awareness)                               | 4.5          | 4.2.2, 5                          | 5.4.2  |
| 4.2                    | Interference with speech communication, acoustic signals  |              |                                   | 5.4.2  |
| <b>7</b>               | <b>Hazards generated by materials and substances</b> (and their constituent elements) processed or used by the machinery: |              |                                   |  |
| 7.1                    | Hazards from contact with or inhalation of harmful fluids and dusts   | 4.8          | 4.3b, 4.4                         | 5.4.3  |
| 7.2                    | Fire  | 4.8          | 4.4                               | 5.4.1  |
| <b>8</b>               | <b>Hazards generated by neglecting ergonomic principles in machinery design:</b>  |              |                                   |  |
| 8.1                    | Unhealthy postures or excessive effort  | 4.9          | 4.7, 4.8.2, 4.11.12, 5.5.5, 5.5.6 | 5.2.2  |
| 8.2                    | Hand-arm or foot-leg anatomy  | 4.9          | 4.8.3                             | 5.3.6  |
| 8.4                    | Local lighting  |              | 4.8.6                             | 6.3  |
| 8.6                    | Human error, human behaviour  | 4.9          | 4.8, 4.11.8, 4.11.10, 5.5.2, 6    | 6.3  |
| 8.7                    | Design, location or identification of manual controls   |              | 4.8.7, 4.11.8                     | 5.2.2  |
| 8.8                    | Design or location of visual display units  |              | 4.8.2, 6.2                        | 5.4.5, 6.2                                   |
| 9                      | Hazard combination  | 4.11         |                                   | 5.2.3, 5.2.5, 5.2.6, 5.2.7, 5.4.9 and 5.4.10 |
| <b>10</b>              | <b>Unexpected start-up, unexpected overrun/overspeed</b> (or any similar malfunction) from:                               |              |                                   |  |
| 10.1                   | Failure/disorder of the control system  |              | 4.11, 5.5.4                       | 5.2.1, 5.2.6, 5.2.7                          |
| 10.2                   | Restoration of energy supply after an interruption  |              | 4.11.4                            | 5.2.6  |
| 10.3                   | External influences on electrical equipment   |              | 4.11.11                           | 5.2.1, 5.4.8, Annex F                        |
| <i>to be continued</i> |   |              |                                   |  |