



SLOVENSKI STANDARD SIST ISO 3550-2:1998

01-februar-1998

7][UfYhY!'8c`c Ub^Y]n[i V'hcVU_UbU_cbW\ `V][UfYh!'&"XY.'A YrcXUi dcfUVY
fchfUrc Y_i V] bY_cW_Yfb]ga YUrcZfz

Cigarettes -- Determination of loss of tobacco from the ends -- Part 2: Method using a rotating cubic box (sismelatophore)

iTeh STANDARD PREVIEW

Cigarettes -- Détermination de la perte de tabac par les extrémités -- Partie 2: Méthode utilisant une boîte rotative cubique (sismélatophore)

SIST ISO 3550-2:1998

Ta slovenski standard je istoveten z: **ISO 3550-2:1997**

<https://standards.iteh.ai/catalog/standards/sist/4f3aac36-e82c-4f8f-b0e0-4c5c425ef610/sist-iso-3550-2-1998>

ICS:

65.160 V[àæ É[àæ} àæ à^| àæ Tobacco, tobacco products
[]!^{ æ and related equipment

SIST ISO 3550-2:1998

en

iTeh STANDARD PREVIEW
(standards.iteh.ai)

SIST ISO 3550-2:1998

<https://standards.iteh.ai/catalog/standards/sist/4f3aac36-e82c-4f8f-b0e0-4e5c425ef610/sist-iso-3550-2-1998>

INTERNATIONAL STANDARD

ISO
3550-2

First edition
1997-09-01

Cigarettes — Determination of loss of tobacco from the ends —

Part 2:

**Method using a rotating cubic box
(sismelatophore)**

iTeh STANDARD PREVIEW

*Cigarettes — Détermination de la perte de tabac par les extrémités —
Partie 2: Méthode utilisant une boîte rotative cubique (sismelatophore)*

[SIST ISO 3550-2:1998](https://standards.iteh.ai/catalog/standards/sist/4f3aac36-e82c-4f8f-b0e0-4e5c425ef610/sist-iso-3550-2-1998)

<https://standards.iteh.ai/catalog/standards/sist/4f3aac36-e82c-4f8f-b0e0-4e5c425ef610/sist-iso-3550-2-1998>



Reference number
ISO 3550-2:1997(E)

ISO 3550-2:1997(E)

Foreword

ISO (the International Organization for Standardization) is a worldwide federation of national standards bodies (ISO member bodies). The work of preparing International Standards is normally carried out through ISO technical committees. Each member body interested in a subject for which a technical committee has been established has the right to be represented on that committee. International organizations, governmental and non-governmental, in liaison with ISO, also take part in the work. ISO collaborates closely with the International Electrotechnical Commission (IEC) on all matters of electrotechnical standardization.

Draft International Standards adopted by the technical committees are circulated to the member bodies for voting. Publication as an International Standard requires approval by at least 75 % of the member bodies casting a vote.

International Standard ISO 3550-2 was prepared by Technical Committee ISO/TC 126, *Tobacco and tobacco products*, Subcommittee SC 1, *Physical and dimensional tests*.

ISO 3550 consists of the following parts, under the general title *Cigarettes — Determination of loss of tobacco from the ends*:

- Part 1: Method using a rotating cylindrical cage
- Part 2: Method using a rotating cubic box (sismelatorphore)

SIST ISO 3550-2:1998

<https://standards.iteh.ai/catalog/standards/sist/4f3aac36-e82c-4f8f-b0e0-4e5c425ef610/sist-iso-3550-2-1998>

© ISO 1997

All rights reserved. Unless otherwise specified, no part of this publication may be reproduced or utilized in any form or by any means, electronic or mechanical, including photocopying and microfilm, without permission in writing from the publisher.

International Organization for Standardization
Case postale 56 • CH-1211 Genève 20 • Switzerland
Internet central@iso.ch
X.400 c=ch; a=400net; p=iso; o=isocs; s=central

Printed in Switzerland

Introduction

The loss of tobacco from cigarette ends, which particularly affects short strands, is a nuisance for the industry as well as for the consumer.

From this standpoint, the greater a cigarette's resistance to loss from its ends, the higher its quality.

The measuring devices available are based on the rotation of a cigarette-containing device. This International Standard describes two particular types of devices. The first, described in ISO 3550-1, comprises a rotating cylindrical cage through which tobacco is allowed to fall into a weighing vessel; the second, described in this part of ISO 3550, uses a cubic box rotating about its main diagonal axis.

The first system principally permits determination of losses undergone by the cigarette during the manufacturing and packaging processes, and the second one losses undergone throughout the distribution network and in the smoker's pocket.

The two methods are not mutually exclusive and other acceptable methods exist which are based upon slightly different types of device.

iTeh STANDARD PREVIEW (standards.iteh.ai)

SIST ISO 3550-2:1998

<https://standards.iteh.ai/catalog/standards/sist/4f3aac36-e82c-4f8f-b0e0-4e5c425ef610/sist-iso-3550-2-1998>

iTeh STANDARD PREVIEW
This page intentionally left blank
(standards.iteh.ai)

SIST ISO 3550-2:1998

<https://standards.iteh.ai/catalog/standards/sist/4f3aac36-e82c-4f8f-b0e0-4e5c425ef610/sist-iso-3550-2-1998>

Cigarettes — Determination of loss of tobacco from the ends —

Part 2:

Method using a rotating cubic box (sismelatophore)

1 Scope

This part of ISO 3550 specifies a method for the determination of loss of tobacco from cigarette ends using a cubic rotative box (sismelatophore).

It applies mainly to the determination of the losses undergone throughout the distribution network and in the smoker's pocket.

NOTE — A method of determination of loss of tobacco from the ends using a rotating cylindrical cage is described in ISO 3550-1.

2 Normative references

The following standards contain provisions which, through reference in this text, constitute provisions of this part of ISO 3550. At the time of publication, the editions indicated were valid. All standards are subject to revision, and parties to agreements based on this part of ISO 3550 are encouraged to investigate the possibility of applying the most recent editions of the standards indicated below. Members of IEC and ISO maintain registers of currently valid International Standards.

ISO 2971:—¹, *Cigarettes and filter rods — Determination of nominal diameter — Method using the laser beam measuring apparatus.*

ISO 3402:1991, *Tobacco and tobacco products — Atmosphere for conditioning and testing.*

ISO 6488:—², *Tobacco — Determination of water content — Karl Fischer method.*

ISO 8243:1991, *Cigarettes — Sampling.*

3 Principle

A test portion of a given number of cigarettes is subjected to a random series of impacts repeated in such a way as to bring about artificially a loss of tobacco strands at the ends.

These impacts are achieved by tumbling the portion in a cubic box revolving uniformly around an axis coincident with a principal diagonal.

The tobacco loss, expressed in parts per thousand (‰), is given by calculating the ratio of the loss of mass of cigarettes in a given time to the initial mass of the test portion.

As a first result of the test, the mass, m_L , of tobacco falling from the test portion is determined. From this mass, m_L , and the non-tobacco mass, m_2 (cigarette paper, filter, glue, etc.), the characteristics of the

¹ To be published. (Revision of ISO 2971:1987)

² To be published. (Revision of ISO 6488:1981)

cigarette (i.e. the loss rate of tobacco, the loss of tobacco per open end and per unit cross section of the open end) are determined.

4 Apparatus

4.1 Conditioning chamber, capable of controlling the enclosed atmosphere in accordance with the requirements of ISO 3402.

4.2 Cubic rotating box (sismelatophore) (see figure 1), consisting of:

- a cubic box, made of poly(methyl methacrylate) or any other plastics material having equivalent properties, the inside edge of which measures $140 \text{ mm} \pm 5 \text{ mm}$, held by two trihedral supports in such a way that one of the principal diagonals is horizontal; one of the faces of the cubic box can be opened (groove or hinge);
- one half-spindle, clamped to a timing micromotor device, which rotates the cube at $60 \text{ min}^{-1} \pm 2 \text{ min}^{-1}$. The other half-spindle supports a spring which holds the cube in position during rotation; this allows the cube to be freed for filling or emptying;
- a time-switch for regulating the duration of operation of the micromotor.

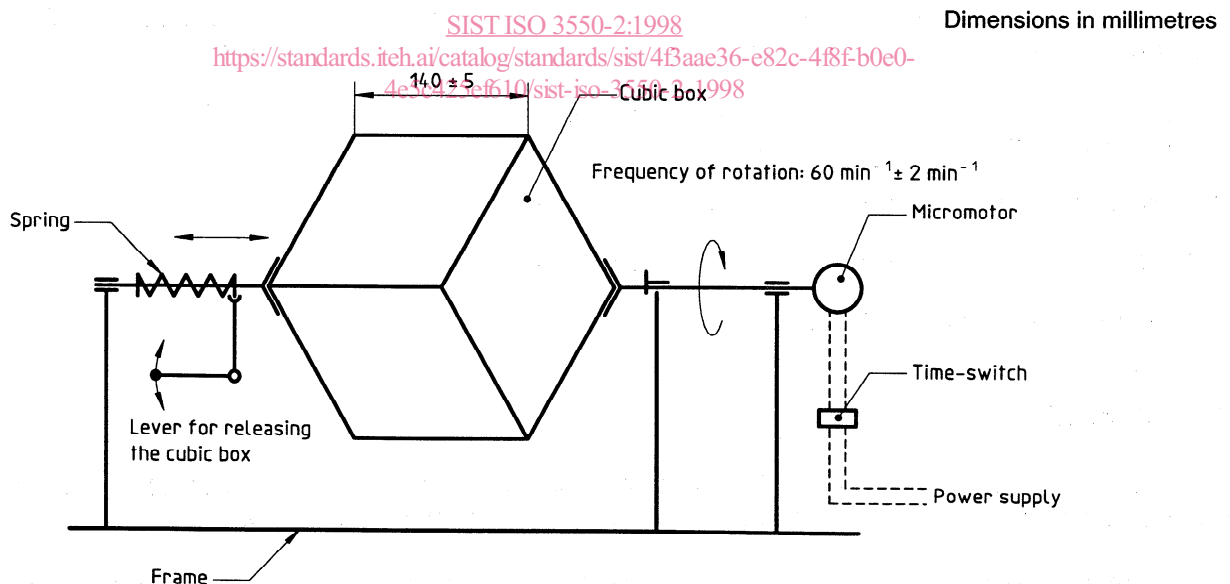

Figure 1 — Cubic rotating box (sismelatophore)

4.3 Device for the measurement of the diameter of the cigarettes, in accordance with ISO 2971.

4.4 Analytical balance, capable of weighing to an accuracy of $\pm 0,000$ 1 g.

5 Sampling

Carry out sampling in accordance with one of the procedures given in ISO 8243 where applicable or, if not, by a procedure relevant to the aim of the test. In the latter case, an appropriate reference to, or details of, the sampling procedure used shall be given in the test report.

6 Procedure

6.1 Conditioning of test sample

Place the test sample in the conditioning chamber (4.1) and condition the sample in accordance with ISO 3402.

6.2 Test portion

Take, as the test portion, 20 cigarettes from the conditioned test sample (see 6.1).

6.3 Determination of water content

Take a new test portion conditioned as specified in 6.1 and determine the water content in accordance with ISO 6488.

NOTE — Although the water content is not used when calculating the loss of tobacco from cigarette ends, it may affect the results considerably. The water content should, therefore, be determined and reported.

6.4 Determination

6.4.1 Operate in the test atmosphere specified in ISO 3402.

6.4.2 Determine the mean diameter of the cigarettes to be tested to the nearest 0,001 mm in accordance with ISO 2971.

6.4.3 Weigh the test portion (6.2) to the nearest 0,001 g, m_0 , immediately introduce it into the sismelatophore (4.2) and operate the apparatus for $120 \text{ s} \pm 6 \text{ s}$.

NOTE — This duration was selected experimentally as giving good sensitivity in an acceptable time.

6.4.4 Open the apparatus and remove the cigarettes with care.

6.4.5 Weigh the test portion again to the nearest 0,001 g after tumbling (m_1) and calculate the fallout quantity $(m_0 - m_1) = m_L$ or weigh directly the mass of the debris collected from the apparatus. Cut the paper lengthways with a sharp blade and separate the tobacco from the paper, adhesive and, if necessary, from the filter (in the case of filter cigarettes). Weigh separately materials other than tobacco (corresponding to mass m_2).

Repeat the test 5 to 10 times according to the accuracy desired.