



# SLOVENSKI STANDARD

## SIST EN 15388:2008

01-julij-2008

---

5 [ `ca Yf]fUb`\_Ua Yb`!`D`cý Yž\_cdUb]ý\_]`YYa Ybh`]b`\_i \ ]b`g\_]`di `hž]nXYUb]`dc  
a Yf]

Agglomerated stone - Slabs and cut-to-size products for vanity and kitchen tops

Künstlich hergestellter Stein - Platten und auf Maß geschnittene Produkte für  
Sanitärbereichs- und Küchenarbeitsflächen

Pierre agglomérée - Dalles et produits mis aux dimensions pour tables de toilette et  
plans de travail

<https://standards.iteh.ai/catalog/standards/sist/a060c319-48ec-4231-89f8-2ffb5da05bd/sist-en-15388-2008>

**Ta slovenski standard je istoveten z: EN 15388:2008**

---

### ICS:

91.100.15 Mineralni materiali in izdelki Mineral materials and products

**SIST EN 15388:2008**

**en,fr,de**

**iTeh STANDARD PREVIEW**  
**(standards.iteh.ai)**

[SIST EN 15388:2008](#)

<https://standards.iteh.ai/catalog/standards/sist/a060c319-48ec-4231-89f8-2ffb5da05bd/sist-en-15388-2008>

ICS 91.100.15

English Version

## Agglomerated stone - Slabs and cut-to-size products for vanity and kitchen tops

Pierre reconstituée - Plaques et produits coupés sur  
mesure pour tables de toilette et plans de travail de cuisine

Künstlich hergestellter Stein - Platten und auf Maß  
geschnittene Produkte für Sanitärbereichs- und  
Küchenarbeitsflächen

This European Standard was approved by CEN on 7 February 2008.

CEN members are bound to comply with the CEN/CENELEC Internal Regulations which stipulate the conditions for giving this European Standard the status of a national standard without any alteration. Up-to-date lists and bibliographical references concerning such national standards may be obtained on application to the CEN Management Centre or to any CEN member.

This European Standard exists in three official versions (English, French, German). A version in any other language made by translation under the responsibility of a CEN member into its own language and notified to the CEN Management Centre has the same status as the official versions.

CEN members are the national standards bodies of Austria, Belgium, Bulgaria, Cyprus, Czech Republic, Denmark, Estonia, Finland, France, Germany, Greece, Hungary, Iceland, Ireland, Italy, Latvia, Lithuania, Luxembourg, Malta, Netherlands, Norway, Poland, Portugal, Romania, Slovakia, Slovenia, Spain, Sweden, Switzerland and United Kingdom.

[SIST EN 15388:2008](https://standards.iteh.ai/catalog/standards/sist/a060c319-48ec-4231-89f8-2ffbc5da05bd/sist-en-15388-2008)

<https://standards.iteh.ai/catalog/standards/sist/a060c319-48ec-4231-89f8-2ffbc5da05bd/sist-en-15388-2008>



EUROPEAN COMMITTEE FOR STANDARDIZATION  
COMITÉ EUROPÉEN DE NORMALISATION  
EUROPÄISCHES KOMITEE FÜR NORMUNG

Management Centre: rue de Stassart, 36 B-1050 Brussels

**Contents**

Page

Foreword.....	3
<b>1 Scope .....</b>	<b>4</b>
<b>2 Normative references .....</b>	<b>4</b>
<b>3 Terms and definitions .....</b>	<b>4</b>
<b>4 Requirements .....</b>	<b>5</b>
4.1 Requirements for geometric characteristics .....	5
4.2 Requirements for surface finish.....	6
<b>5 Characteristics of agglomerated stones for vanity and kitchen tops .....</b>	<b>7</b>
5.1 General.....	7
5.2 Denomination .....	7
5.3 Visual appearance .....	7
5.4 Reference sample, visual inspection and acceptance criteria .....	7
5.5 Reaction to fire.....	8
5.6 Apparent density and water absorption.....	8
5.7 Flexural strength.....	8
5.8 Thermal conductivity.....	8
5.9 Thermal shock resistance.....	8
5.10 Impact resistance.....	8
5.11 Chemical resistance .....	8
5.12 Linear thermal expansion coefficient.....	9
5.13 Electrical resistivity .....	9
<b>6 Marking, labelling and packaging .....</b>	<b>9</b>
<b>7 Evaluation of conformity.....</b>	<b>9</b>
7.1 Evaluation for conformity – General rules .....	9
7.2 Initial type testing of the agglomerated stone material properties .....	9
7.3 Factory production control – Tests to be carried out by the manufacturer .....	10
<b>Bibliography .....</b>	<b>12</b>

iTech STANDARD PREVIEW  
 (standards.iteh.ai)  
 SIST EN 15388:2008  
<https://standards.iteh.ai/catalog/standards/sist/a060c319-48ec-4231-89f8-211bc5da05bd/sist-en-15388-2008>

## Foreword

This document (EN 15388:2008) has been prepared by Technical Committee CEN/TC 246 “Natural stones”, the secretariat of which is held by UNI.

This European Standard shall be given the status of a national standard, either by publication of an identical text or by endorsement, at the latest by September 2008, and conflicting national standards shall be withdrawn at the latest by September 2008.

Attention is drawn to the possibility that some of the elements of this document may be the subject of patent rights. CEN [and/or CENELEC] shall not be held responsible for identifying any or all such patent rights.

This European Standard is one of a series of standards for specifications of agglomerated stone products which includes the following:

- EN 15285, Agglomerated stone – Modular tiles for flooring and stairs (internal and external),
- prEN 15286, Agglomerated stone – Slabs and tiles for wall finishes (internal and external).

According to the CEN/CENELEC Internal Regulations, the national standards organizations of the following countries are bound to implement this European Standard: Austria, Belgium, Bulgaria, Cyprus, Czech Republic, Denmark, Estonia, Finland, France, Germany, Greece, Hungary, Iceland, Ireland, Italy, Latvia, Lithuania, Luxembourg, Malta, Netherlands, Norway, Poland, Portugal, Romania, Slovakia, Slovenia, Spain, Sweden, Switzerland and the United Kingdom.

[SIST EN 15388:2008](https://standards.iteh.ai/catalog/standards/sist/a060c319-48ec-4231-89f8-2ffbc5da05bd/sist-en-15388-2008)

<https://standards.iteh.ai/catalog/standards/sist/a060c319-48ec-4231-89f8-2ffbc5da05bd/sist-en-15388-2008>

## 1 Scope

This European Standard specifies requirements for slabs and cut-to-size products of agglomerated stone which are made for use as vanity and kitchen tops, or other similar use in furnishing.

## 2 Normative references

The following referenced documents are indispensable for the application of this document. For dated references, only the edition cited applies. For undated references, the latest edition of the referenced document (including any amendments) applies.

EN 13501-1, *Fire classification of construction products and building elements – Part 1: Classification using data from reaction to fire tests*

EN 14617-1, *Agglomerated stone – Test methods – Part 1: Determination of apparent density and water absorption*

EN 14617-2, *Agglomerated stone – Test methods – Part 2: Determination of flexural strength (bending)*

EN 14617-6, *Agglomerated stone – Test methods – Part 6: Determination of thermal shock resistance*

EN 14617-9, *Agglomerated stone – Test methods – Part 9: Determination of impact resistance*

EN 14617-10, *Agglomerated stone – Test methods – Part 10: Determination of chemical resistance*

EN 14617-11, *Agglomerated stone – Test methods – Part 11: Determination of linear thermal expansion coefficient*

EN 14617-13, *Agglomerated stone – Test methods – Part 13: Determination of electrical resistivity*

EN 14617-16, *Agglomerated stone – Test methods – Part 16: Determination of dimensions, geometric characteristics and surface quality of modular tiles*

EN 14618:2005, *Agglomerated stone – Terminology and classification*

NOTE In addition to the European Standards for test methods mentioned in clause 2, there exist further test method standards which can be used for scientific examinations, but which are not relevant for the application in practice according to this standard.

## 3 Terms and definitions

For the purposes of this document, the terms and definitions given in EN 14618:2005 and the following apply.

**3.1 slab for vanity and kitchen tops**  
flat slab which can be obtained from the sawing of a block, directly from moulding or cut-to-size which form a covering for use in furnishing, fixed to a structure either mechanically or by means of specific adhesives

NOTE Rough products are obtained from the sawing of a block, directly from moulding, refining the edges and finishing the surface.

The products cut-to-size can be subsequently used to manufacture composites whose tolerances and performances do not fall under the responsibility of the producer of the agglomerated stone slab

### 3.2

#### dimensions of slab for vanity and kitchen tops

length  $l$ , width  $b$  and thickness  $d$  of a slab for use in furnishing. The dimensions are given in the stated sequence in millimetres (see Figure 1)

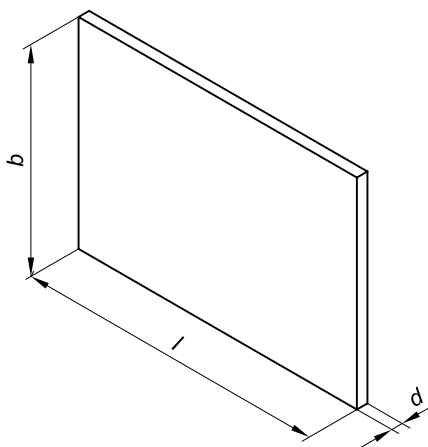

Figure 1 — Dimensions of the slab

## 4 Requirements iTeh STANDARD PREVIEW

(standards.iteh.ai)

### 4.1 Requirements for geometric characteristics

#### 4.1.1 General

SIST EN 15388:2008

[https://standards.iteh.ai/catalog/standards/sist/a060c319-48ec-4231-89f8-](https://standards.iteh.ai/catalog/standards/sist/a060c319-48ec-4231-89f8-28fbc5da05fd/sist-en-15388-2008)

[28fbc5da05fd/sist-en-15388-2008](https://standards.iteh.ai/catalog/standards/sist/a060c319-48ec-4231-89f8-28fbc5da05fd/sist-en-15388-2008)

All measured values of individual units shall fall within the required tolerances. The measurement shall be performed by a Venier calliper or other suitable apparatus for linear measurements to the nearest 0,1 mm.

#### 4.1.2 Requirements for thickness

The thickness shall not deviate from the nominal thickness by more than  $\pm 1,2$  mm.

The thickness shall result from an analysis which takes into account the whole size of the slab. The nominal thickness shall be the result of 3 measurements for each meter of the slab length.

Stricter tolerances may be declared by the manufacturer. This is particularly important when the edges of the slabs will be visible.

#### 4.1.3 Requirements for flatness

The deviation from flatness of the surface shall not exceed 4 mm over the slab length and shall not exceed 2 mm over the slab width.

Flatness shall be measured in the middle of the slab using the full length and width (not the diagonals) when the slab is horizontal.

#### 4.1.4 Requirements for length and width of rough products

The length and width shall not deviate from the nominal size by more than given in Table 1.

Stricter tolerances may be declared by the manufacturer.

**Table 1 — Tolerances for length and width**

Nominal length/width in mm	Tolerances
From 1850 to 3060 (nominal length)	-20 mm / +10 mm
From 1250 to 1400 (nominal width)	-15 mm / +10 mm
For other nominal lengths and widths tolerances shall be calculated proportionally.	

**4.1.5 Requirements for special shapes (only for cut-to-size products)**

Pieces of special or irregular shapes shall be checked for compliance with the required shape. The permissible tolerance at any point shall be  $\pm 1,2$  mm, which may be measured by using a suitable template.

Stricter tolerances may be declared by the manufacturer.

**4.2 Requirements for surface finish**

**4.2.1 General**

Surface finishes shall extend uniformly to the edges of the slab. The uniformity shall be guaranteed on at least 90 % of the total surface of the element

Stricter values may be declared by the manufacturer.

**4.2.2 Requirements for surfaces after surface finishing**

Surfaces shall have a regular appearance as a function of the finishing process and shall be worked to meet the finish declared (e.g. by submission of samples beforehand between the purchaser and supplier).

The surface roughness of the visible face can be directly obtained by moulding and to present an aspect structured with relief.

Example of the surface finishes are:

- sandblasted surfaces (obtained for example by means of a sandblasting action),
- fine ground surfaces (obtained for example by means of a grinding disk of grain size F 200),
- honed finished surfaces (obtained for example by means of a polishing disk with grain size F 400),
- highly polished surfaces (obtained for example by means of a polishing disk or felt),
- structured aspect (obtained by catch of print or artistic creation).

If other types of surface finishes are used, these shall be declared by the manufacturer.

For finely ground surfaces, honed surfaces and highly polished surfaces, it falls under the responsibility of the manufacturer to declare, according to the colour of the product, the minimum degree of gloss to be expected.

**4.2.3 Requirements for the unexposed surface**

The unexposed surface shall have a regular appearance. Small cracks or cuts are permitted within 10 cm from the sides of the slabs.



When the finishing process for the unexposed surface foresees a calibrated surface, the maximum surface roughness shall not exceed 0,5 mm.

## 5 Characteristics of agglomerated stones for vanity and kitchen tops

### 5.1 General

The following characteristics shall be declared when subject to regulatory requirements and may be declared otherwise with reference to the conditions of the end usage.

Contractual specifications may be used to establish reference values e.g. stated in design or supplier data sheet, due account taken of any regulatory requirements applicable.

### 5.2 Denomination

The denomination shall always be declared.

The denomination is the indication of the commercial family of the product, commercial type, binders and type of aggregate, see EN 14618.

### 5.3 Visual appearance

This characteristic shall always be declared.

The colour, surface finish, etc. of the agglomerated stone shall be identified visually e.g. by a range of samples selected in agreement by supplier and purchaser.

Any aesthetic visual variation is permissible provided that it is a declared aspect of the relevant type of agglomerated stone and provided that it does not adversely affect the performance of the slabs.

### 5.4 Reference sample, visual inspection and acceptance criteria

A reference sample shall be an adequate number of pieces of agglomerated stone of sufficient size to indicate the general appearance of the finished work. The dimensions of individual pieces shall be at least 0,01 m<sup>2</sup> (typical values are between 0,01 and 0,25 m<sup>2</sup> in face area but may be more) and shall indicate the range of general appearance regarding the colouring, the physical structure and the surface finish.

The reference sample does not imply strict uniformity between the sample itself and the actual supply (e.g. variations in tonality may always occur due to natural raw materials). All the differences in aesthetical pattern between the slabs and the reference sample shall be considered typical of the agglomerated stone and not as flaws. Therefore they shall not become a reason for rejection, unless their presence exceeds 15 % of the surface and the typical pattern of the agglomerated stone is lost.

Any comparison between production slab and reference sample shall be carried out by placing the reference sample in a vertical position against the production slab and viewing them at a distance of about two metres under normal daylight conditions and recording any visible differences in the characteristics of the agglomerated stone.

NOTE The pieces should be analysed under similar conditions: for example, wet/dry, light, etc.

According to this method, the difference in tonality and the gloss value (in the case of finely ground, honed or highly polished surfaces) measured at six different points of the slab shall be evaluated.