INTERNATIONAL STANDARD



2759

INTERNATIONAL ORGANIZATION FOR STANDARDIZATION • МЕЖДУНАРОДНАЯ ОРГАНИЗАЦИЯ ПО СТАНДАРТИЗАЦИИ • ORGANISATION INTERNATIONALE DE NORMALISATION

Board — Determination of bursting strength

Carton — Détermination de la résistance à l'éclatement

First edition — 1974-11-01

UDC 676.017.42 : 539.42

Ref. No. ISO 2759-1974 (E)

Descriptors : papers, paperboards, tests, mechanical tests, burst tests.

Price based on 7 pages

FOREWORD

ISO (the International Organization for Standardization) is a worldwide federation of national standards institutes (ISO Member Bodies). The work of developing International Standards is carried out through ISO Technical Committees. Every Member Body interested in a subject for which a Technical Committee has been set up has the right to be represented on that Committee. International organizations, governmental and non-governmental, in liaison with ISO, also take part in the work.

Draft International Standards adopted by the Technical Committees are circulated to the Member Bodies for approval before their acceptance as International Standards by the ISO Council.

International Standard ISO 2759 was drawn up by Technical Committee ISO/TC 6, *Paper, board and pulps*, and circulated to the Member Bodies in July 1972.

It has been approved by the Member Bodies of the following countries :

Australia	India	South Africa, Rep. of
Austria	Iran	<u>Spain</u>
Belgium	Ireland	Sweden
Czechoslovakia	Israel	Switzerland
Egypt, Arab Rep. of	Netherlands	Thailand
Finland	New Zealand	Turkey
France	Norway	United Kingdom
Germany	Poland	U.S.A.
Hungary	Romania	

No Member Body expressed disapproval of the document.

Board — Determination of bursting strength

0 INTRODUCTION

This International Standard is applicable to boards with bursting strengths between 350 kPa (250 kPa for the components of boards with a combined bursting strength of above 350 kPa) and 5 500 kPa.

An alternative method for materials with bursting strengths of less than 1 100 kPa is given in ISO 2758.

Many instruments in use for determining this property are at present scaled in kilograms-force per square centimetre. For the purpose of this International Standard, $1 \text{ kgf/cm}^2 = 98,1 \text{ kPa}$.

1 SCOPE

This International Standard specifies a method for measuring the bursting strength of board submitted to increasing hydraulic pressure.

2 FIELD OF APPLICATION

This International Standard is applicable in principle to all types of board (including solid and corrugated fibreboard) with bursting strengths within the range 350 to 5 500 kPa.

It may also be used for papers or boards with bursting strength as low as 250 kPa if the paper or board is to be used to prepare a material of higher bursting strength, such as corrugated board. In such cases, the measurements will not necessarily have the accuracy or precision stated for this method and the test report shall carry a note that the test gave results that were below the minimum value required by the method.

3 REFERENCES

ISO/R 186, *Method of sampling paper for testing*.

ISO/R 187, *Method for the conditioning of paper and board test samples*.¹⁾

ISO/R 536, *Determination of paper substance*.¹⁾

ISO 2758, *Paper — Determination of bursting strength*.

4 DEFINITIONS

For the purpose of this International Standard, the following definitions apply:

4.1 bursting strength: The maximum uniformly distributed pressure, applied at right angles to its surface, that a test piece of board will stand under the conditions of this test.

4.2 burst index: The bursting strength of the board divided by the grammage of the conditioned board determined by the standard method of the test.

5 PRINCIPLE

A test piece, placed over a circular elastic diaphragm, is rigidly clamped at the periphery but free to bulge with the diaphragm. Hydraulic fluid is pumped at a constant rate, bulging the diaphragm until the test piece ruptures. The bursting strength of the test piece is the maximum value of the applied hydraulic pressure.

6 APPARATUS

The apparatus shall be installed on a horizontal surface and be free from externally induced vibrations.

All air shall be removed from the hydraulic system by bleeding. The apparatus shall be checked for expansion and for leaks using the methods given in annex E.

6.1 Clamping system for clamping the test piece firmly and uniformly between two annular plane, parallel, hard surfaces, which shall be smooth (but not polished) and grooved as described in annex A, which also gives the dimensions of the clamping system.

The upper clamping plate shall be held in a swivel joint or otherwise so as to ensure that the clamping pressure is distributed evenly.

During tests, the apertures in the two clamping plates shall be concentric to within 0,25 mm and the clamping surfaces shall be flat and parallel. Methods of checking the clamps are given in annex B.

1) At present under revision.

For materials other than corrugated boards the clamping force shall be sufficient to prevent slippage during a test but not so great as to damage the test piece in such a way that rupture occurs around the periphery of the test area. Normally the clamping force shall be not less than 5 000 N (see annex C).

For corrugated boards, two alternative methods of clamping may be used :

a) a minimum clamping force of 5 000 N is applied. This is equivalent to about 800 kPa on most instruments and is sufficient to collapse the flutes of the clamped area of most corrugated boards, but generally holds the test piece without slippage.

b) a clamping force sufficient to hold the board without excessive slippage during the test, but not to collapse the flutes is applied.

Under this condition some slippage occurs with most boards.

Maximum and minimum clamping forces may be agreed between the parties concerned.

The clamping pressure or force used shall be given in the test report which, for corrugated boards, shall also state whether the corrugations collapsed under the conditions used.

In the absence of any agreement to the contrary a minimum clamping force of 5 000 N shall be used.

6.2 Diaphragm, circular, of elastic material, clamped securely with its upper surface about 5,5 mm below the top plane of the lower clamping plate. The material and construction of the diaphragm shall be such as to require the following pressure to bulge the diaphragm above the top face of the lower clamp :

— bulge height: 10 mm, pressure range: 170 to 220 kPa;

— bulge height: 18 mm, pressure range: 250 to 350 kPa.

A new diaphragm will frequently require a higher pressure for a given bulge height than one which has been used for a while. Diaphragms shall be checked at frequent intervals and re-fitted or changed if the bulge height requirements are not met. Care shall be taken during the fitting of a diaphragm to eliminate all air trapped under the diaphragm.

6.3 Hydraulic system to apply a controlled hydraulic pressure to the underside of the diaphragm until the test piece bursts. The pressure shall be generated by a piston forcing a suitable liquid (chemically pure glycerol, ethylene glycol containing a corrosion inhibitor, or a low viscosity silicone oil) against the under surface of the diaphragm. The hydraulic system and liquid used shall be free from air bubbles. The pumping rate shall be 170 ± 15 ml/min (see annex E).

The piston shall be motor operated.

6.4 Pressure gauge, maximum reading Bourdon type, of appropriate capacity. It shall preferably be used within the range 25 to 75 % and in no case outside the range 15 to 85 % of the capacity of the scale¹⁾. The scale shall have a minimum diameter of 95 mm and graduations extending over a minimum arc of 270° . At any point within the working range it shall be accurate to within $\pm 0,5$ % of the maximum capacity of the scale. The scale shall be sub-divided into at least 70 divisions.

The expansibility of the gauge shall be constant to within ± 20 % over its full working range and be such that the hydraulic fluid required to give a full scale reading does not exceed 0,4 ml (see annex E). The gauge shall be fitted with a scale adjustment device for fine setting.

The maximum reading pointer shall not introduce errors into the scale readings during use. This can only be confirmed by dynamic calibration of the gauge, but gauges with pointers having a frictional couple of about 0,3 mN·m and a moment of inertia of between 1 and 10 g·cm² have been found to be satisfactory (see annex D).

The gauge shall be provided with a bleed hole or other device to facilitate the complete filling of the gauge with hydraulic fluid.

The total measuring range of the instrument may be divided by the use of two gauges. The gauges shall be independent of each other in use; by checking the expansibility of the system on each range with the selector valve in the appropriate position, the suitability of the selector valve will be confirmed (see annex E).

7 CALIBRATION

Each gauge shall be calibrated before initial use and afterwards at sufficiently frequent intervals to maintain the specified accuracy. A deadweight tester may be used (see annex D). Calibration shall be carried out with the gauge mounted in the same position as it occupies on the instrument and preferably when mounted on the instrument. If the gauge is accidentally used beyond its capacity it shall be recalibrated before being used again.

1) Unless the capacity of the gauge is known to exceed the graduated scale reading by 20 %, in which case the upper limits of scale reading may be increased to 90 % and 100 % respectively.

8 SAMPLING AND PREPARATION OF TEST PIECES

The board to be tested shall be sampled in accordance with ISO/R 186. Test pieces shall be larger in area than the clamp of the burst tester and no area covered by the clamp in one test shall be included in subsequent test areas.

Test pieces shall not include areas containing creases, or visible damage.

Test pieces shall be conditioned in accordance with ISO/R 187.

The number of test pieces required depends on whether or not separate results are required for burst tests carried out with each surface in contact with the diaphragm.

NOTE — When laboratory sheets are being tested and when only narrow samples are available for testing, it may not be possible to avoid the clamped area overlapping the edges of the test piece or an adjacent clamped area. In such instances the overlap shall be carefully minimized and the test piece inspected after use to ensure that the overlap has not caused the clamped board to slip. If clamping is not in accordance with the stated procedure this fact shall be stated in the test report.

9 PROCEDURE

Tests shall be carried out in a standard atmosphere as defined in ISO/R 187, used for the conditioning of test pieces in accordance with clause 8.

Where alternative gauges are available, select the most suitable gauge, if necessary by carrying out a preliminary test using the gauge with the greatest range, and isolate the other gauges.

Raise the clamp and insert the test piece in a position enabling the full clamping area to be used (see note to clause 8); then firmly apply the clamp to the test piece at the appropriate clamping force specified in 6.1.

Apply hydraulic pressure at the correct rate until the test piece bursts. Retract the piston, until the diaphragm is below the level of the lower clamping plate. Read the pressure indicated on the gauge to three significant figures. Then release the clamp and return the maximum reading pointer to its starting position for the next test. Readings shall be rejected when visible slippage of the test piece (as shown by movement of the test piece area outside the clamps or by creasing of the test piece in the clamped area) has occurred. In cases of doubt, the use of a larger test piece will frequently establish whether slippage is occurring. Readings shall also be rejected if the type of failure (for example severance at the periphery of the test zone) indicates that the test piece was damaged by excessive clamping pressure or by rotation of the clamps during clamping.

NOTE — Care shall be taken when returning the pointer to the starting position. On some instruments too rapid a return may damage the pointer.

If separate results are required with each surface of the board in contact with the diaphragm, twenty tests shall be carried out for each result. If separate results are not required for the two surfaces of the material, ten tests shall be made with one side uppermost and ten tests with the other side uppermost.

NOTE — The surface in contact with the diaphragm is considered as the surface under test.

10 CALCULATION AND EXPRESSION OF RESULTS

The burst index, X , in kilonewtons per gram, may be calculated from the bursting strength as follows :

$$X = \frac{P}{W}$$

where

P is the mean bursting strength in kilopascals;

W is the grammage of the specimen, in grams per square metre, determined in accordance with ISO/R 536.

11 PRECISION OF RESULTS

The precision of results depends to a great extent on the variability of the material tested and the accuracy on a large number of factors, the most important possibly being the efficiency of clamping.

It is difficult under practical circumstances to separate these but some typical results will illustrate the variations likely to be encountered.

Within laboratory (12 materials) :

Coefficient of variation of individual results 3,8 to 8,5 %;

95 % confidence limits of mean result $\pm 1,8$ to 4,0 %.

Between laboratories (randomized test pieces) :

Coefficient of variation of mean results 5,8 to 9,6 %.

Thus it can be seen that, generally, differences in the mean results for two boards of less than about 5 % on a single instrument or about 10 % on instruments in different laboratories cannot be taken as proof of a real difference in bursting strength.

12 SOURCES OF ERROR

The main sources of error are :

— faulty calibration of the pressure gauge (see annex D);

— incorrect rate of rise of pressure (increased rates lead to an apparent increase in bursting strength) (see annex E);

- incorrect diaphragm (see 6.2);
- inadequate or uneven clamping (which generally leads to an apparent increase in bursting strength) (see annexes B and C);
- air in the system (which generally leads to an apparent decrease in bursting strength) (see annex E).

13 TEST REPORT

The test report shall include the following particulars :

- a) a reference to this International Standard;
- b) the date and place of testing, the make of instrument and the model number;

- c) the standard conditioning atmosphere used;
- d) the mean value of the bursting strength in kilopascals to three significant figures (from each surface of the board where appropriate);
- e) if required, the burst index to three significant figures;
- f) the 95 % confidence limits of the mean bursting strength;
- g) the clamping pressure or clamping force used;
- h) in the case of corrugated boards, whether corrugation collapse occurred;
- i) any deviations from the recommended method.

ANNEX A

DIMENSIONS OF THE CLAMPING SYSTEM

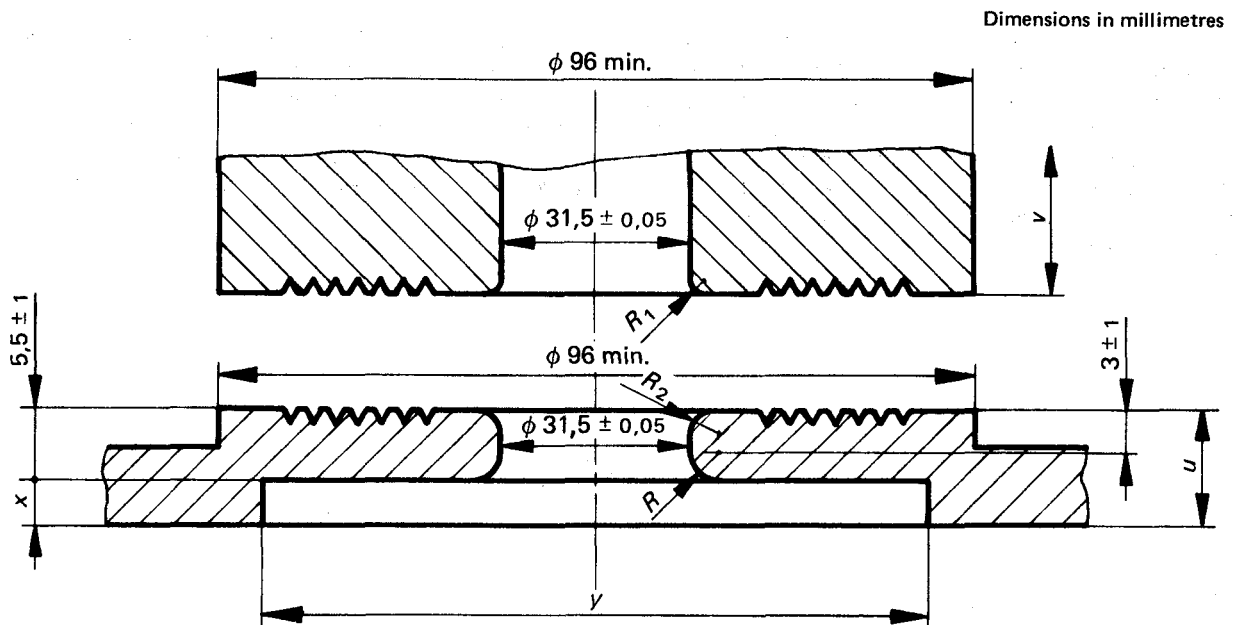

R , R_1 , R_2 , u , v , x and y are specified in the text.

FIGURE — The clamps

Dimensions u and v are not critical but shall be large enough to ensure that the clamps do not distort during use. For the top clamp, a minimum thickness of 9,5 mm has been found satisfactory in use.

Dimensions x and y depend on the construction of the remainder of the burst tester and on the diaphragm used but shall be such that the diaphragm is securely clamped.

Radius R is set by the limits imposed by the dimensions $5,5 \pm 1$ and 3 ± 1 mm. The arc shall be tangential to the vertical face of the orifice and to the horizontal bottom surface of the lower clamp. The radius shall be about 3 mm.

To reduce the danger of damage to the test piece or diaphragm, R_1 and R_2 shall be slightly rounded off. Radii of curvature of about 0,6 mm for R_1 and 0,4 mm for R_2 are recommended.

To minimize slippage, the clamp surfaces which come into contact with the board during test shall have spiral or concentric tool marks in the surface.

The following have been found very satisfactory :

- a) a continuous spiral 60° V-groove not less than 0,25 mm deep, with a pitch of $0,9 \pm 0,1$ mm, the groove starting at $3,2 \pm 0,1$ mm from the edge of the circular opening;
- b) a series of concentric 60° V-grooves not less than 0,25 mm deep and $0,9 \pm 0,1$ mm apart, the centre of the innermost groove being $3,2 \pm 0,1$ mm from the edge of the circular opening.

The space above the orifice in the upper clamp shall be of sufficient size to allow free bulging of the test piece and shall be connected to the atmosphere by an orifice of sufficient size to allow air trapped above the test piece to escape. An orifice of diameter about 4 mm has been found adequate.