



SLOVENSKI STANDARD
SIST-TS CEN ISO/TS 17892-4:2004
01-december-2004

; YchM b] bc`dfY]g_cj Ub`Y]b`dfYg_i yUb`Y`E`@UvcfUrcf]`g_c`dfYg_i yUb`Y`nYa``j]b`E`
("XY. :I [cHJ`Ub`Y`nfbUj cglbY`gYglUj Y`fIGC#HG`%&, - &!(.&\$\$ (£

Geotechnical investigation and testing - Laboratory testing of soil - Part 4: Determination of particle size distribution (ISO/TS 17892-4:2004)

Geotechnische Erkundung und Untersuchung - Laborversuche an Bodenproben - Teil 4: Bestimmung der Korngrößenverteilung (ISO/TS 17892-4:2004)

Reconnaissance et essais géotechniques - Essais de laboratoire sur les sols - Partie 4: Détermination de la distribution granulométrique des particules (ISO/TS 17892-4:2004)

<https://standards.iteh.ai/catalog/standards/sist/a7c569f7-8c52-434a-b09e-eebd9ce52aa0/sist-ts-cen-iso-ts-17892-4-2004>

Ta slovenski standard je istoveten z: CEN ISO/TS 17892-4:2004

ICS:

13.080.20	Fizikalne lastnosti tal	Physical properties of soils
93.020	Zemeljska dela. Izkopavanja.	Earthworks. Excavations.
	Gradnja temeljev. Dela pod zemljo	Foundation construction. Underground works

SIST-TS CEN ISO/TS 17892-4:2004 en

iTeh STANDARD PREVIEW
(standards.iteh.ai)

[SIST-TS CEN ISO/TS 17892-4:2004](https://standards.iteh.ai/catalog/standards/sist/a7c569f7-8c52-434a-b09e-ebd9ce52aa0/sist-ts-cen-iso-ts-17892-4-2004)

<https://standards.iteh.ai/catalog/standards/sist/a7c569f7-8c52-434a-b09e-ebd9ce52aa0/sist-ts-cen-iso-ts-17892-4-2004>

TECHNICAL SPECIFICATION
SPÉCIFICATION TECHNIQUE
TECHNISCHE SPEZIFIKATION

CEN ISO/TS 17892-4

October 2004

ICS 13.080.20; 93.020

English version

**Geotechnical investigation and testing - Laboratory testing of
soil - Part 4: Determination of particle size distribution (ISO/TS
17892-4:2004)**

Reconnaissance et essais géotechniques - Essais de sol
au laboratoire - Partie 4: Détermination de la granulométrie
(ISO/TS 17892-4:2004)

Geotechnische Erkundung und Untersuchung -
Laborversuche an Bodenproben - Teil 4: Bestimmung der
Korngrößenverteilung (ISO/TS 17892-4:2004)

This Technical Specification (CEN/TS) was approved by CEN on 2 December 2003 for provisional application.

The period of validity of this CEN/TS is limited initially to three years. After two years the members of CEN will be requested to submit their comments, particularly on the question whether the CEN/TS can be converted into a European Standard.

CEN members are required to announce the existence of this CEN/TS in the same way as for an EN and to make the CEN/TS available promptly at national level in an appropriate form. It is permissible to keep conflicting national standards in force (in parallel to the CEN/TS) until the final decision about the possible conversion of the CEN/TS into an EN is reached.

CEN members are the national standards bodies of Austria, Belgium, Cyprus, Czech Republic, Denmark, Estonia, Finland, France, Germany, Greece, Hungary, Iceland, Ireland, Italy, Latvia, Lithuania, Luxembourg, Malta, Netherlands, Norway, Poland, Portugal, Slovakia, Slovenia, Spain, Sweden, Switzerland and United Kingdom.

<https://standards.iteh.ai/catalog/standards/sist/a7c569f7-8c52-434a-b09e-cebd9ce52aa0/sist-ts-cen-iso-ts-17892-4-2004>



EUROPEAN COMMITTEE FOR STANDARDIZATION
COMITÉ EUROPÉEN DE NORMALISATION
EUROPÄISCHES KOMITEE FÜR NORMUNG

Management Centre: rue de Stassart, 36 B-1050 Brussels

CEN ISO/TS 17892-4:2004 (E)

Contents

Foreword.....	3
1 Scope	5
2 Normative references	5
3 Terms and definitions	6
4 Equipment	6
4.1 General.....	6
4.2 Sieving	7
4.3 Hydrometer method.....	7
5 Test procedure	10
5.1 Selection of test method	10
5.2 Sieving	10
5.3 Hydrometer analysis	15
6 Test results.....	21
6.1 Sieving	21
6.2 Hydrometer.....	21
6.3 Pipette method	23
7 Test report	24
Annex A (informative) Calibration of hydrometer	26
A.1 Volume calibration.....	26
A.2 Scale calibration	26
A.3 Meniscus correction.....	27
Annex B (informative) Calibration of hydrometer	29
B.1 Pretreatment for organic material.....	29
B.2 Pretreatment for carbonate material.....	29
B.3 Final pretreatment stage.....	29
Bibliography	30

Tables

Table 1 — Minimum mass required for sieving as a function of particle diameter D_{90}	12
Table 2 — Maximum mass of soil retained on each sieve.....	14
Table 3 — Dry mass of soil specimen for sedimentation test.....	17
Table 4 — Insertion depth of pipette.....	20
Table 5 — Dynamic viscosity of water.....	23
Table A.1 — Temperature correction.....	28

Figures

Figure 1 — Example of pipette configuration	9
Figure 2 — Sieving procedure	11
Figure 3 — General procedure for sedimentation	16
Figure 4 — Example of a particle size distribution result.....	25
Figure A.1 — Example of calibration of hydrometer scale	27

Foreword

This document (CEN ISO/TS 17892-4:2004) has been prepared by Technical Committee CEN/TC 341 "Geotechnical investigation and testing", the secretariat of which is held by DIN, in collaboration with Technical Committee ISO/TC 182 "Geotechnics".

According to the CEN/CENELEC Internal Regulations, the national standards organizations of the following countries are bound to announce this Technical Specification: Austria, Belgium, Cyprus, Czech Republic, Denmark, Estonia, Finland, France, Germany, Greece, Hungary, Iceland, Ireland, Italy, Latvia, Lithuania, Luxembourg, Malta, Netherlands, Norway, Poland, Portugal, Slovakia, Slovenia, Spain, Sweden, Switzerland and United Kingdom.

CEN ISO/TS 17892 consists of the following parts, under the general title *Geotechnical investigation and testing — Laboratory testing of soil*:

- Part 1: Determination of water content
- Part 2: Determination of density of fine grained soil
- Part 3: Determination of particle density - Pycnometer method
- Part 4: Determination of particle size distribution
- Part 5: Incremental loading oedometer test
- Part 6: Fall cone test
- Part 7: Unconfined compression test on fine grain soils
- Part 8: Unconsolidated undrained triaxial test
- Part 9: Consolidated triaxial compression tests on water saturated soils
- Part 10: Direct shear tests
- Part 11: Determination of permeability by constant and falling head
- Part 12: Determination of the Atterberg limits

CEN ISO/TS 17892-4:2004 (E)**Introduction**

This document covers areas in the international field of geotechnical engineering never previously standardised. It is intended that this document presents broad good practice throughout the world and significant differences with national documents is not anticipated. It is based on international practice (see [1]).

**iTeh STANDARD PREVIEW
(standards.iteh.ai)**

[SIST-TS CEN ISO/TS 17892-4:2004](https://standards.iteh.ai/catalog/standards/sist/a7c569f7-8c52-434a-b09e-ebd9ce52aa0/sist-ts-cen-iso-ts-17892-4-2004)

<https://standards.iteh.ai/catalog/standards/sist/a7c569f7-8c52-434a-b09e-ebd9ce52aa0/sist-ts-cen-iso-ts-17892-4-2004>

1 Scope

This document describes methods for the determination of the particle size distribution of soil samples.

The particle size distribution is one of the most important physical characteristics of soil. Classification of soils is mainly based on the particle size distribution. Many geotechnical and geohydrological properties of soil are related to the particle size distribution.

The particle size distribution provides a description of soil, based on a subdivision in discrete classes of particle sizes. The size of each class can be determined by sieving and/or sedimentation. For soils with less than 10 % fines, the sieving method is applicable. Soils with more than 10 % fines can be analysed by a combination of sieving and sedimentation.

Sieving is the process whereby the soil is separated in particle size classes by the use of test sieves. Sedimentation is the process of the setting of soil particles in a liquid. The difference in settling rate enables the particle size classes to be separated. Two sedimentation methods are described; the hydrometer method and the pipette method.

The methods described are applicable to all non-cemented soils with particle sizes less than 125 mm.

Depending on the purpose for the determination of the particle size distribution, pretreatment or correction for calcium carbonate, dissolved salts and/or organic matter can be required. The use of these methods should be stated in the laboratory report.

Modern methods that incorporate detection systems using x-rays, laser beams, density measurements and particle counters are not covered by this document.

[SIST-TS CEN ISO/TS 17892-4:2004](https://standards.iteh.ai/catalog/standards/sist/a7c569f7-8c52-434a-b09e-cebd9ce52aa0/sist-ts-cen-iso-ts-17892-4-2004)

<https://standards.iteh.ai/catalog/standards/sist/a7c569f7-8c52-434a-b09e-cebd9ce52aa0/sist-ts-cen-iso-ts-17892-4-2004>

2 Normative references

The following referenced documents are indispensable for the application of this document. For dated references, only the edition cited applies. For undated references, the latest edition of the referenced document (including any amendments) applies.

CEN ISO/TS 17892-1, *Geotechnical investigation and testing — Laboratory testing of soil — Part 1: Determination of water content (ISO/TS 17892-1:2004)*.

CEN ISO/TS 17892-3, *Geotechnical investigation and testing — Laboratory testing of soil — Part 3: Determination of particle density — Pycnometer method (ISO/TS 17892-3:2004)*.

ISO 565, *Test sieves - Metal wire cloth, perforated metal plate and electroformed sheet - Nominal sizes of openings*.

ISO 3310-1, *Test sieves - Technical requirements and testing - Part 1: Test sieves of metal wire cloth*.

ISO 3310-2, *Test sieves - Technical requirements and testing - Part 2: Test sieves of perforated metal plate*.

CEN ISO/TS 17892-4:2004 (E)

3 Terms and definitions

For the purposes of this document, the following terms and definitions apply.

3.1

particle size distribution

proportions by mass of the various particle size classes present in a specific soil

3.2

equivalent diameter

particle diameter calculated from sedimentation data using Stoke's law, and assuming spherical particles

3.3

coarse-grained cohesionless soils

soils comprising gravel and/or sand sized particles with less than about 10 % of fines, and which are virtually non-cohesive

NOTE The fines content is measured only quantitatively, by difference after washing the material away.

3.4

fine-grained soils

soils comprising more than about 10 % of fines, sometimes with sand but with little or no gravel-sized particles. This category includes both non-cohesive and cohesive soils

3.5

mixed soils

soils comprising gravel, sand, and more than about 10 % of fines

iTeh STANDARD PREVIEW
(standards.iteh.ai)

NOTE These soils may or may not be cohesive, depending on the amount of clay present.

3.6

fines

particles passing the 0,063 mm sieve

[SIST-TS CEN ISO/TS 17892-4:2004](https://standards.iteh.ai/catalog/standards/sist/a7c569f7-8c52-434a-b09e-eebd9ce52aa0/sist-ts-cen-iso-ts-17892-4-2004)

<https://standards.iteh.ai/catalog/standards/sist/a7c569f7-8c52-434a-b09e-eebd9ce52aa0/sist-ts-cen-iso-ts-17892-4-2004>

3.7

D_{90}

the smallest sieve mesh aperture through which 90 % or more of the particles will pass

4 Equipment

4.1 General

4.1.1 Balances

Balances shall have an accuracy of 0,3 % of the total dry specimen mass and a readability of 0,1 % of total dry specimen mass.

4.1.2 Drying ovens

Drying ovens shall be capable of maintaining a temperature of $105\text{ °C} \pm 5\text{ °C}$ and $50\text{ °C} \pm 5\text{ °C}$.

4.1.3 Desiccator

Desiccator shall contain anhydrous silica gel.

WARNING — Traditional blue self-indicating silica gel contains cobalt chloride which has been reclassified as potential carcinogen by inhalation by EU Directive 98/98/EC.

4.1.4 Evaporating dish

Evaporating dish shall be made of porcelain or non-corroding metal, having a minimum content of 100 ml.

4.1.5 Sieves

Sieves shall comprise a sieve of 0,063 mm, suitably reinforced for use as a washing sieve, with receiver, and one sieve of 2,0 mm.

4.2 Sieving

4.2.1 Test sieves

Test sieves of metal wire cloth or perforated metal plate in accordance with ISO 565 and ISO 3310, together with appropriate receivers shall be used.

The aperture of the test sieves should adequately cover the range for the particular soil tested, but it is recommended that within the full range of 125 mm to 0,063 mm not less than 12 sieves are used. The smallest test sieve should have an aperture of 0,063 mm. The number of sieves used shall be sufficient to ensure that any discontinuities in the grading curve are detected. The test sieves should be visually checked before every use.

4.2.2 Ancillary apparatus

The ancillary apparatus shall consist of

- corrosion resistant trays;
- large corrosion resistant or plastic tray or bucket;
- scoop;
- sieve brushes;
- rubber tubing;
- cylindrical beaker, 800 ml or more;
- riffle box (optional);
- mechanical sieve shaker (optional).

iteh STANDARD PREVIEW
(standards.iteh.ai)

[SIST-TS CEN ISO/TS 17892-4:2004](#)

<https://standards.iteh.ai/catalog/standards/sist/a7c569f7-8c52-434a-b09e-eebd9ce52aa0/sist-ts-cen-iso-ts-17892-4-2004>

4.3 Hydrometer method

4.3.1 Hydrometer

The hydrometer shall be torpedo-shaped and made of glass as free as possible from visible defects. The glass shall be resistant to chemicals and well annealed. The hydrometer stem and bulb shall be circular in cross section and symmetrical around the main axis, without abrupt change in cross section. The hydrometer shall always float, at all points within its range, within the stem within 1,5° of the vertical. The scale and inscription shall be marked clearly and permanently, showing no apparent irregularities in spacing. The graduation lines shall be at intervals of 0,0005 g/ml and the range of the hydrometer shall be between 0,9950 g/ml and 1,0300 g/ml. The hydrometer shall be indelibly marked with a unique identification number.

4.3.2 Graduated glass cylinders

Graduated glass cylinders shall be provided with parallel sides and with constant cross sectional area across their length. The diameter shall be at least twice that of the hydrometer bulb and the length be sufficient to ensure that the hydrometer can float freely in 1000 ml of pure water.

CEN ISO/TS 17892-4:2004 (E)**4.3.3 Thermometers**

Thermometer shall cover a temperature range of 0 °C to 50 °C and be accurate to 0,5 °C.

4.3.4 Water bath

The water bath shall be insulated and may have a temperature controller.

4.3.5 Mechanical shaker or mixer

The mechanical shaker or mixer shall be capable of keeping the appropriate quantities of soil and water in continuous suspension.

4.3.6 Timer

The stop watch or stop clock shall be readable to 1 s.

4.3.7 Working bench

The working bench shall be free from vibrations.¹⁾

4.3.8 Centrifuge

The centrifuge or vacuum filter and ancillaries, or any other apparatus shall be suitable for separating out the soil particles following pretreatment for the removal of salts, organic and/or calcareous matter (optional).

4.4 Pipette method**4.4.1 Pipette**

[SIST-TS CEN ISO/TS 17892-4:2004
https://standards.iteh.ai/catalog/standards/sist/a7c569f7-8c52-434a-b09e-cebd9ce52aa0/sist-ts-cen-iso-ts-17892-4-2004](https://standards.iteh.ai/catalog/standards/sist/a7c569f7-8c52-434a-b09e-cebd9ce52aa0/sist-ts-cen-iso-ts-17892-4-2004)

The pipette shall be calibrated. It shall have a volume of 20 ml and be mounted in a pipette configuration (Figure 1).

1) Free from vibrations means no ripples can be seen on the surface of a suspension placed on the working bench.

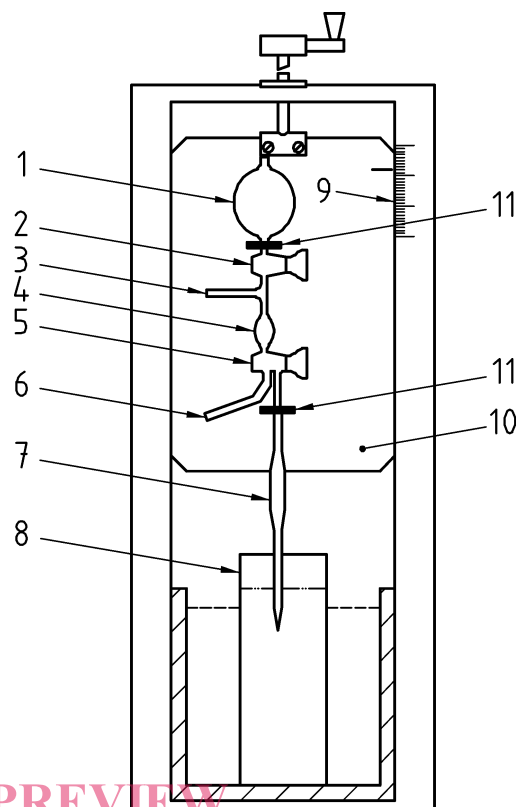
**Key**

- 1 Bulb
- 2 Stop cock
- 3 Safety bulb suction inlet
- 4 Safety bulb
- 5 Three-way stop cock
- 6 Outlet tube
- 7 Sampling pipette
- 8 Sedimentation cylinder
- 9 Graduated scale
- 10 Sliding panel
- 11 Clamps

iTeh STANDARD PREVIEW
(standards.iteh.ai)

Figure 1 — Example of pipette configuration

[SIST-TS CEN ISO/TS 17892-4:2004](https://standards.iteh.ai/catalog/standards/sist/a7c569f7-8c52-434a-b09e-eebd9ce52aa0/sist-ts-cen-iso-ts-17892-4-2004)

4.4.2 Balance <https://standards.iteh.ai/catalog/standards/sist/a7c569f7-8c52-434a-b09e-eebd9ce52aa0/sist-ts-cen-iso-ts-17892-4-2004>

The balance shall have an accuracy of 0,3 mg.

4.4.3 Thermometers

Thermometers shall cover a temperature range of 0 °C to 50 °C and be accurate to 0,5 °C.

4.4.4 Water bath

The water bath shall be insulated and may have a temperature controller.

4.4.5 Mechanical shaker or mixer

The mechanical shaker or mixer shall be capable of keeping the appropriate quantities of soil and water in continuous suspension.

4.4.6 Timer

A stop watch or stop clock shall be readable to 1 s.

4.4.7 Working bench

The working bench shall be free from vibrations.^{a)}

4.4.8 Centrifuge

The centrifuge or vacuum filter and ancillaries, or any other apparatus shall be suitable for separating out the soil particles following pretreatment for the removal of salts, organic and/or calcareous matter (optional).

CEN ISO/TS 17892-4:2004 (E)

4.5 Reagents

4.5.1 General

Reagents shall be of analysis quality.

4.5.2 Water

The water shall be distilled, de-ionised or demineralised.

4.5.3 Dispersing agent

The dispersing agent may be water. However, if flocculation occurs, this can be prevented by adding a dispersing agent. Options include but are not limited to:

- Sieving: sodium hexametaphosphate, approximately 2 g/l or sodium pyrophosphate, approximately 2 g/l;
- Sedimentation: sodium hexametaphosphate approximately 40 g/l (0,07 M) or sodium pyrophosphate, approximately 20 g/l (0,07 M).

Solutions shall be renewed monthly. Sodium carbonate shall not be added to the sodium hexametaphosphate.

4.5.4 Hydrogen peroxide

Hydrogen peroxide (20% V/V) may be used to remove organic material.

4.5.5 Hydrochlorid acid

Hydrochlorid acid (0,2 M (± 1 %)) may be used to remove carbonates (optional).

iteh STANDARD PREVIEW
(standards.iteh.ai)
SIST-TS CEN ISO/TS 17892-4:2004
<https://standards.iteh.ai/catalog/standards/sist/a7c569f7-8c52-434a-b09e-eebd9ce52aa0/sist-ts-cen-iso-ts-17892-4-2004>

5 Test procedure

5.1 Selection of test method

The test method shall be selected as follows:

For mixed soils separate sieving and sedimentation shall be performed.

If 90 % or more of the particles are larger than 0,063 mm sieving shall be performed.

If more than 10 % of the particles are smaller than 0,063 mm sedimentation shall be performed.

If the complete curve of the grain size distribution is required, sieving and sedimentation test shall be carried out.

5.2 Sieving

5.2.1 General

5.2.1.1 The general procedure for sieving is outlined in Figure 2.