**Safety of machinery — Safety distances to
prevent danger zones being reached by the
lower limbs**

*Sécurité des machines — Distances de sécurité pour empêcher l'atteinte des
zones dangereuses par les membres inférieurs*

iTeh STANDARD PREVIEW
(standards.iteh.ai)

[ISO 13853:1998](https://standards.iteh.ai/catalog/standards/sist/e0f95e33-146c-4582-b574-ad9325143e4d/iso-13853-1998)

[https://standards.iteh.ai/catalog/standards/sist/e0f95e33-146c-4582-b574-
ad9325143e4d/iso-13853-1998](https://standards.iteh.ai/catalog/standards/sist/e0f95e33-146c-4582-b574-ad9325143e4d/iso-13853-1998)



Contents	Page
1 Scope.....	1
2 Normative references	1
3 Definitions	2
4 Safety distances to prevent access by lower limbs	2
5 Distances to impede free access by lower limbs	4
Annex A Impeding free movement under protective structures.....	5
Annex B European equivalents to cited normative International Standards.....	6

iTeh STANDARD PREVIEW
(standards.iteh.ai)

<https://standards.iteh.ai/catalog/standards/sist/e0f95e33-146c-4582-b574-ad9325143e4d/iso-13853-1998>

© ISO 1998

All rights reserved. Unless otherwise specified, no part of this publication may be reproduced or utilized in any form or by any means, electronic or mechanical, including photocopying and microfilm, without permission in writing from the publisher.

International Organization for Standardization
Case postale 56 • CH-1211 Genève 20 • Switzerland
Internet iso@iso.ch

Printed in Switzerland

Foreword

ISO (the International Organization for Standardization) is a worldwide federation of national standards bodies (ISO member bodies). The work of preparing International Standards is normally carried out through ISO technical committees. Each member body interested in a subject for which a technical committee has been established has the right to be represented on that committee. International organizations, governmental and non-governmental, in liaison with ISO, also take part in the work. ISO collaborates closely with the International Electrotechnical Commission (IEC) on all matters of electrotechnical standardization.

Draft International Standards adopted by the technical committees are circulated to the member bodies for voting. Publication as an International Standard requires approval by at least 75 % of the member bodies casting a vote.

iTeh STANDARD PREVIEW

International Standard ISO 13853 was prepared by Technical Committee ISO/TC 199, *Safety of machinery*. It has been published by the European Committee for Standardization (CEN) as EN 811:1996.

[ISO 13853:1998](https://standards.iteh.ai/catalog/standards/sist/60410e3d-2024-4000-9325-143e4d/iso-13853-1998)

[Annexes A and B of this International Standard are for information only.](https://standards.iteh.ai/catalog/standards/sist/60410e3d-2024-4000-9325-143e4d/iso-13853-1998)

Introduction

In accordance with ISO/TR 12100-1, in general machinery is said to be safe if it is probable that the machinery can perform its function, to be transported, installed, adjusted, maintained, dismantled and disposed of under the conditions of its intended use without causing injury or damaging human health.

One method of eliminating or reducing risks caused by machinery is to make use of safety distances preventing danger zones from being reached. This International Standard specifies safety distances only for the lower limbs. Safety distances for the upper limbs are covered by ISO 13852.

Sometimes reasonably foreseeable reach situations can occur, e.g. while persons

- try to use a foot to clean out discharge and/or feed openings, or
- operate foot-controlled machinery.

In specifying safety distances to prevent lower-limb access (see clause 4) and distances to impede free access (see clause 5), a number of aspects have to be taken into consideration, such as:

- reach situations of the lower limbs occurring when machinery is being used;
- reliable surveys of anthropometric data, taking into account ethnic groups likely to be found in the countries concerned;
- biomechanical facts, such as compression and stretching of parts of the human body and limits of joint rotation;
- technical and practical aspects.

If these aspects were further developed, the current state of the art reflected in this International Standard could be improved.

Safety of machinery — Safety distances to prevent danger zones being reached by the lower limbs

1 Scope

This International Standard establishes values for safety distances to prevent access and distances to impede free access to machinery danger zones to prevent their being reached by the lower limbs of persons of 14 years of age and above.

NOTE 1 The values given are based on practical experience which has been found to be adequate for this group of persons.

These distances apply when adequate safety can be achieved by distance alone, and when access by the upper limbs is not foreseeable according to the risk assessment.

NOTE 2 These safety distances will not provide sufficient protection against certain hazards, for example radiation and emission of substances. For such hazards, additional or other measures need to be taken.

The safety distances to prevent access relate to openings, and serve to protect those persons trying to reach danger zones under the conditions specified for different reaching situations.

The distances to impede free access relate to the height from ground level to the protective structure, and serve to reduce risk to persons by limiting the free movement of the lower limbs.

NOTE 3 If persons below 14 years of age are to be taken into account, it is not relevant to establish values other than those for upper limbs. In this case the safety distances to prevent danger zones being reached by the upper limbs, derived from table 5 of ISO 13852:1996, will apply.

For certain applications, there are justifiable reasons to deviate from these distances. Standards dealing with these applications should indicate how adequate safety can be achieved.

2 Normative references

The following standards contain provisions which, through reference in this text, constitute provisions of this International Standard. At the time of publication, the editions indicated were valid. All standards are subject to revision, and parties to agreements based on this International Standard are encouraged to investigate the possibility of applying the most recent editions of the standards listed below. Members of IEC and ISO maintain registers of currently valid International Standards.

ISO/TR 12100-1:1992, *Safety of machinery — Basic concepts, general principles for design — Part 1: Basic terminology, methodology*.

ISO 13852:1996, *Safety of machinery — Safety distances to prevent danger zones being reached by the upper limbs*.

ISO 14121:—¹, *Safety of machinery — Principles for risk assessment*.

¹) To be published.

3 Definitions

For the purposes of this International Standard, the definitions given in ISO/TR 12100-1 and ISO 13852 apply.

4 Safety distances to prevent access by lower limbs

4.1 General

4.1.1 Assumptions

The safety distances have been derived by making the following assumptions:

- the protective structures and any openings in them retain their shape and position; otherwise further consideration shall be given to achieve adequate safety;
- safety distances are measured from the surface restricting the body or the relevant part of the body.

4.1.2 Risk assessment

A risk assessment (see ISO/TR 12100-1 and ISO 14121) shall be made before determination of the required safety distance for preventing reaching danger zones.

This International Standard shall be used if the risk assessment justifies that there is a risk only to the lower limbs. Where there is a risk to both upper and lower limbs, then for a given opening the largest safety distance given in table 1 of this International Standard or in table 4 of ISO 13852:1996 shall be used.

The minimum safety distances s_r given in table 1 apply to persons reaching through openings using the lower limbs in an attempt to reach a danger zone.

4.2 Reaching through openings using the lower limbs

4.2.1 Openings of regular shape

The dimension e of openings corresponds to the side of a square opening, the diameter of a round opening or the narrowest dimension of a slot opening.

Slot openings with $e > 180$ mm and square or round openings with $e > 240$ mm will allow access for the whole body.

The values given in table 1 are independent of whether clothing or footwear is being worn.

4.2.2 Openings of irregular shape

In the case of openings of irregular shape, the following steps shall be carried out.

a) Determine first:

- the diameter of the smallest round opening and
- the side of the smallest square opening and
- the width of the narrowest slot opening

into which the irregular opening can be completely inserted (see hatched area in figure 1).

- b) Select the corresponding three safety distances in accordance with table 1.
- c) The shortest safety distance of the three values selected in b) can be used as the safety distance for this opening of irregular shape.

Table 1

Dimensions in millimetres

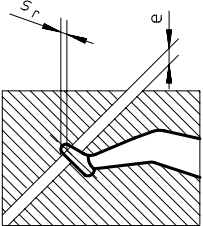
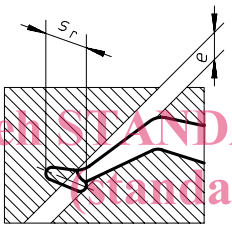
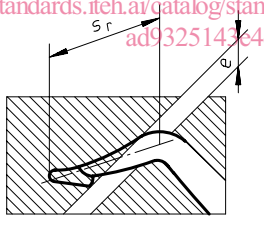
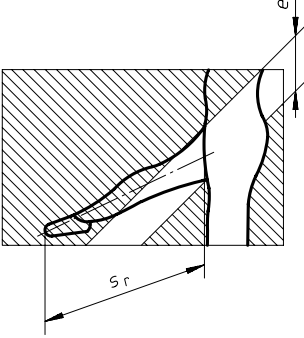
Part of lower limb	Illustration	Opening	Safety distance s_r	
			Slot	Square or round
Toe tip		$e \leq 5$	0	0
Toe		$5 < e \leq 15$	≥ 10	0
		$15 < e \leq 35$	$\geq 80^1)$	≥ 25
Foot		$35 < e \leq 60$	≥ 180	≥ 80
		$60 < e \leq 80$	$\geq 650^2)$	≥ 180
Leg (toe tip to knee)		$80 < e \leq 95$	$\geq 1100^3)$	$\geq 650^2)$
		$95 < e \leq 180$	$\geq 1100^3)$	$\geq 1100^3)$
Leg (toe tip to crotch)		$180 < e \leq 240$	not admissible	$\geq 1100^3)$

1) If the length of the slot opening is ≤ 75 mm, the distance can be reduced to ≥ 50 mm.
 2) The value corresponds to Leg (toe tip to knee).
 3) The value corresponds to Leg (toe tip to crotch).

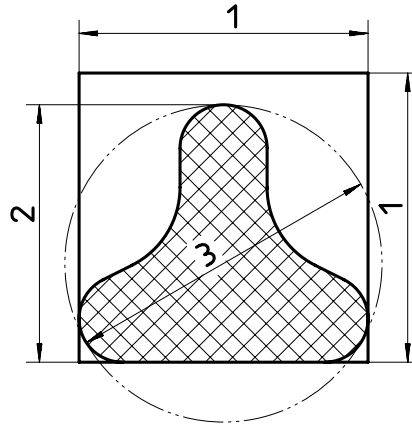
**Key**

- 1 Side
- 2 Width
- 3 Diameter

Figure 1**5 Distances to impede free access by lower limbs**

An additional protective structure can be used to restrict the free movement of the lower limbs under existing protective structures. For this method, the distances given in annex A relate to the height from the ground or reference plane to the protective structure.

NOTE 1 This method provides limited protection; in many cases other methods will be more appropriate.

NOTE 2 Additional precautions may be required to restrict access of the upper limbs and/or to prevent access of the whole body to the danger zone.

Annex A
(informative)

Impeding free movement under protective structures

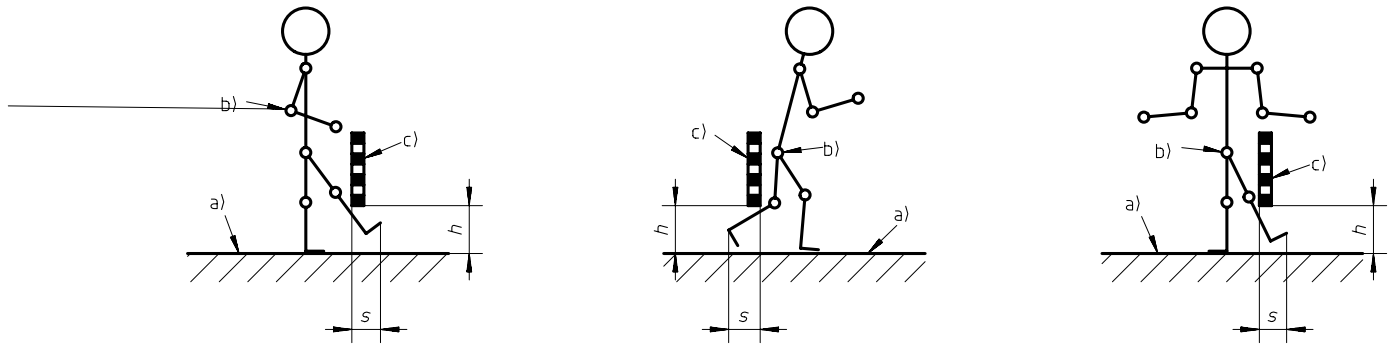

- a) Reference plane
- b) Hip joint
- c) Protective structure
- h Height to protective structure
- s Safety distance for impedance

Figure A.1

Table A.1 gives distances s for particular cases where access of the lower limbs is impeded with the person remaining in a standing position (see figure A.1) without any additional support.

Where there is a risk of slipping or misuse, applying the values given in table A.1 can be inappropriate.

There should be no interpolation between the values in this table. If the height h up to the protective structure lies between two values, then the distance for the higher value of h should be used.

Table A.1

Dimensions in millimetres

Height, h , up to protective structure	Distance s		
	Case 1	Case 2	Case 3
$h \leq 200$	≥ 340	≥ 665	≥ 290
$200 < h \leq 400$	≥ 550	≥ 765	≥ 615
$400 < h \leq 600$	≥ 850	≥ 950	≥ 800
$600 < h \leq 800$	≥ 950	≥ 950	≥ 900
$800 < h \leq 1000$	≥ 1125	≥ 1195	≥ 1015