



# SLOVENSKI STANDARD

## SIST EN 14187-9:2006

01-april-2006

---

### Hladno nanosljive tesnilne mase za stike – 9. del: Preskušanje funkcionalnosti tesnilnih mas za stike

Cold applied joint sealants - Test methods - Part 9: Function testing of joint sealants

Kalt verarbeitbare Fugenmassen - Prüfverfahren - Teil 9: Funktionsprüfung von Fugenmassen

Mastics pour joints appliqués a froid - Methodes d'essai - Partie 9 : Fonctionnalité des mastics pour joints

iTeh STANDARD PREVIEW

(standards.itteh.ai)

SIST EN 14187-9:2006

Ta slovenski standard je istoveten z: EN 14187-9:2006

<https://standards.itteh.ai/catalog/standards/sist/b7e02213-c5d4-4b9d-871c-001001a5d4fe/sist-en-14187-9-2006>

---

#### ICS:

91.100.50	Veziva. Tesnilni materiali	Binders. Sealing materials
93.080.20	Materiali za gradnjo cest	Road construction materials

**SIST EN 14187-9:2006**

**en**

**iTeh STANDARD PREVIEW**  
**(standards.iteh.ai)**

SIST EN 14187-9:2006

<https://standards.iteh.ai/catalog/standards/sist/b7e02213-c5d4-4b9d-871c-60f0b1a5d4fe/sist-en-14187-9-2006>

EUROPEAN STANDARD  
NORME EUROPÉENNE  
EUROPÄISCHE NORM

**EN 14187-9**

February 2006

ICS 93.080.20

English Version

## Cold applied joint sealants - Test methods - Part 9: Function testing of joint sealants

Mastics pour joints appliqués à froid - Méthodes d'essai -  
Partie 9 : Fonctionnalité des mastics pour joints

Kalt verarbeitbare Fugenmassen - Prüfverfahren - Teil 9:  
Funktionsprüfung von Fugenmassen

This European Standard was approved by CEN on 30 December 2005.

CEN members are bound to comply with the CEN/CENELEC Internal Regulations which stipulate the conditions for giving this European Standard the status of a national standard without any alteration. Up-to-date lists and bibliographical references concerning such national standards may be obtained on application to the Central Secretariat or to any CEN member.

This European Standard exists in three official versions (English, French, German). A version in any other language made by translation under the responsibility of a CEN member into its own language and notified to the Central Secretariat has the same status as the official versions.

CEN members are the national standards bodies of Austria, Belgium, Cyprus, Czech Republic, Denmark, Estonia, Finland, France, Germany, Greece, Hungary, Iceland, Ireland, Italy, Latvia, Lithuania, Luxembourg, Malta, Netherlands, Norway, Poland, Portugal, Romania, Slovakia, Slovenia, Spain, Sweden, Switzerland and United Kingdom.

SIST EN 14187-9:2006

<https://standards.iteh.ai/catalog/standards/sist/b7e02213-c5d4-4b9d-871c-60f0b1a5d4fe/sist-en-14187-9-2006>



EUROPEAN COMMITTEE FOR STANDARDIZATION  
COMITÉ EUROPÉEN DE NORMALISATION  
EUROPÄISCHES KOMITEE FÜR NORMUNG

Management Centre: rue de Stassart, 36 B-1050 Brussels

Contents	Page
Foreword .....	3
1 Scope .....	4
2 Normative references .....	4
3 Terms and definitions .....	4
4 Principle.....	4
5 Apparatus and materials .....	4
5.1 Concrete test blocks .....	4
5.2 Tensile/compression test rig.....	4
5.3 Climate chamber .....	5
5.4 Temperature indicator .....	5
6 Preparation of the test specimens.....	5
7 Procedure .....	6
7.1 Conditioning cycle .....	6
7.2 After conditioning .....	8
7.3 Test procedure .....	8
8 Calculation and expression of results.....	9
9 Test report .....	10

SIST EN 14187-9:2006  
<https://standards.iteh.ai/catalog/standards/sist/b7e02213-c5d4-4b9d-871c-60f0b1a5d4fe/sist-en-14187-9-2006>

## Foreword

This European Standard (EN 14187-9:2006) has been prepared by Technical Committee CEN/TC 227 "Road materials", the secretariat of which is held by DIN.

This European Standard shall be given the status of a national standard, either by publication of an identical text or by endorsement, at the latest by August 2006, and conflicting national standards shall be withdrawn at the latest by December 2006.

This European Standard is one of a series of standards as listed below:

EN 14187-1, *Cold applied joint sealants - Part 1: Test method for the determination of rate of cure*

EN 14187-2, *Cold applied joint sealants - Part 2: Test method for the determination of tack free time*

EN 14187-3, *Cold applied joint sealants - Part 3: Test method for the determination of self-levelling properties*

EN 14187-4, *Cold applied joint sealants - Part 4: Test method for the determination of the change in mass and volume after immersion in test fuel*

EN 14187-5, *Cold applied joint sealants - Part 5: Test method for the determination of the resistance to hydrolysis*

EN 14187-6, *Cold applied joint sealants - Part 6: Test method for the determination of the adhesion/cohesion properties after immersion in chemical liquids*

EN 14187-7, *Cold applied joint sealants - Part 7: Test method for the determination of the resistance to flame*

EN 14187-8, *Cold applied joint sealants - Part 8: Test method for the determination of the artificial weathering by UV-irradiation*

EN 14187-9, *Cold applied joint sealants — Part 9: Test method for the function testing of joint sealants*

No existing European Standard is superseded.

According to the CEN/CENELEC Internal Regulations, the national standards organizations of the following countries are bound to implement this European Standard: Austria, Belgium, Cyprus, Czech Republic, Denmark, Estonia, Finland, France, Germany, Greece, Hungary, Iceland, Ireland, Italy, Latvia, Lithuania, Luxembourg, Malta, Netherlands, Norway, Poland, Portugal, Romania, Slovakia, Slovenia, Spain, Sweden, Switzerland and United Kingdom.

**EN 14187-9:2006 (E)****1 Scope**

This European Standard specifies a function test for cold applied joint sealants intended for use in joints in roads and airfield pavements in cold climate areas where the total joint movement can be greater than 35 % and the temperature can go below  $-25\text{ }^{\circ}\text{C}$ .

**2 Normative references**

The following referenced documents are indispensable for the application of this document. For dated references, only the edition cited applies. For undated references, the latest edition of the referenced document (including any amendments) applies.

EN 13880-12, *Hot applied joint sealants - Part 12: Test method for the manufacture of concrete test blocks for bond testing (recipe methods)*

EN 14187-2, *Cold applied joint sealants - Part 2: Test method for the determination of tack free time*

EN 26927:1990, *Building construction - Jointing products - Sealants - Vocabulary (ISO 6927:1981)*

EN ISO 7390, *Building construction - Jointing products - Determination of resistance to flow of sealants (ISO 7390:2003)*

iTeh STANDARD PREVIEW  
(standards.iteh.ai)

**3 Terms and definitions**

For the purposes of this European Standard, the terms and definitions given in EN 26927:1990 apply.

SIST EN 14187-9:2006  
<https://standards.iteh.ai/catalog/standards/sist/b7e02213-c5d4-4b9d-871c-60f0b1a5d4fe/sist-en-14187-9-2006>

**4 Principle**

This method describes an accelerated test for the assessment of damage of the cold applied sealants arising from the influence of fluctuating temperatures, water-spraying and simultaneous dynamic load.

**5 Apparatus and materials****5.1 Concrete test blocks**

Concrete supports in accordance with EN 13880-12, for the preparation of the test specimens, of dimensions as shown in Figure 1. Two supports are required for each test specimen.

**5.2 Tensile/compression test rig**

Apparatus, which allows specimens to be inserted into holding clamps, conveniently and without disturbing the specimens before, during or after removal shall be used. The apparatus shall be capable of testing a number of test specimens simultaneously and shall not be significantly affected by the failure of one or more specimens.

The apparatus shall have the following characteristics:

- Be motor driven through positive drives without slip or significant backlash, so that cycles of extension and compression are carried out steadily and automatically;

- be capable of moving the test blocks and specimens smoothly and linearly, so that their alignment is maintained at all times without subjecting them to torsion, bending, shock, or significant vibration;
- be capable of exerting on each specimen an appropriate tensile/compression force and extending the specimen uniformly under the specified conditions according to 7.2 and 7.4;
- be capable of measuring and recording the force with an uncertainty of maximum 2 % after application of the force to each system;
- the tolerance of the movement shall not exceed 0,01 mm.

### 5.3 Climate chamber

Climate chamber shall be capable of reducing the temperature of the specimens to the specified temperature in the range from  $-30\text{ }^{\circ}\text{C}$  to  $30\text{ }^{\circ}\text{C}$  drop/rise throughout the period of examination.

The chamber shall be fitted with a time controlled device to allow the specimen to be subjected to spraying with distilled or demineralized water for 20 % of the total conditioning time at the fixed temperatures as provided in 7.4.

### 5.4 Temperature indicator

The temperature indicator shall consist of an electronic device capable of measuring temperatures in the range of  $-40\text{ }^{\circ}\text{C}$  to  $50\text{ }^{\circ}\text{C}$  to an accuracy of  $\pm 1\text{ }^{\circ}\text{C}$ .

## 6 Preparation of the test specimens

For each test, at least three test specimens shall be prepared.

Prepare the test specimens in accordance with the manufacturer's instructions including the application of a primer, etc. where stipulated. The test specimens shall be as shown in Figure 1.

Prior to conditioning, the gelation time of the sealant shall be determined in the following way.

Measure tack free time in accordance with EN 14187-2. Thereafter, prepare test specimens in accordance with EN ISO 7390.

After the preparation, place test specimens in standard conditions ( $(23 \pm 2)\text{ }^{\circ}\text{C}$ ,  $(50 \pm 5)\text{ \% r. h.}$ ).

Examine the first test specimen as described in EN ISO 7390, procedure B after the time equal to the tack free time. If no flow is observed, the gelation time is equal to the tack free time. In other cases, the examination shall be repeated in steps of additional 10% of the tack free time until no flow is observed.

Prepare the test specimens and immediately after the sealant has gelled carefully mount them in the tensile test rig.

Dimensions in millimetres

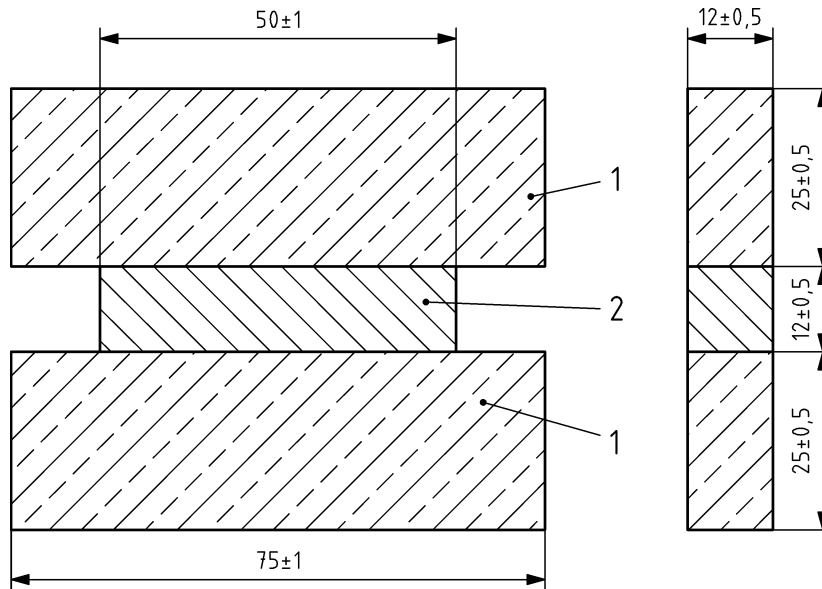
**Key**

- 1 Concrete test blocks
- 2 Sealant

**iTeh STANDARD PREVIEW**  
(standards.iteh.ai)

**Figure 1 — Test specimen mounted between the concrete test blocks**

[SIST EN 14187-9:2006](https://standards.iteh.ai/catalog/standards/sist/b7e02213-c5d4-4b9d-871c-60f0b1a5d4fe/sist-en-14187-9-2006)

<https://standards.iteh.ai/catalog/standards/sist/b7e02213-c5d4-4b9d-871c-60f0b1a5d4fe/sist-en-14187-9-2006>

**7 Procedure****7.1 Conditioning cycle**

Prior to testing, the test specimens shall be subjected to the conditioning procedure described below.

Mount the test specimens on a tensile test rig in the climate chamber as shown in Figure 2.

Subject the test specimens to the following conditioning cycle shown in Figure 3.

Temperature cycling:    minimum temperature     $(10 \pm 1) ^\circ\text{C}$ ,  
   maximum temperature     $(25 \pm 1) ^\circ\text{C}$ .

Rate of deformation:     $(0,010 \pm 0,002) \text{ mm/min}$ .

Movement:                Extension                     $(0,40 \pm 0,03) \text{ mm}$              $(3,33 \pm 0,25) \%$ ,  
   Compression                 $(0,10 \pm 0,03) \text{ mm}$              $(0,83 \pm 0,25) \%$ .

Water spraying:            20 % of total time (1 min water spraying, 4 min pause),  
   Water temperature         $10 ^\circ\text{C}$  to  $20 ^\circ\text{C}$ .

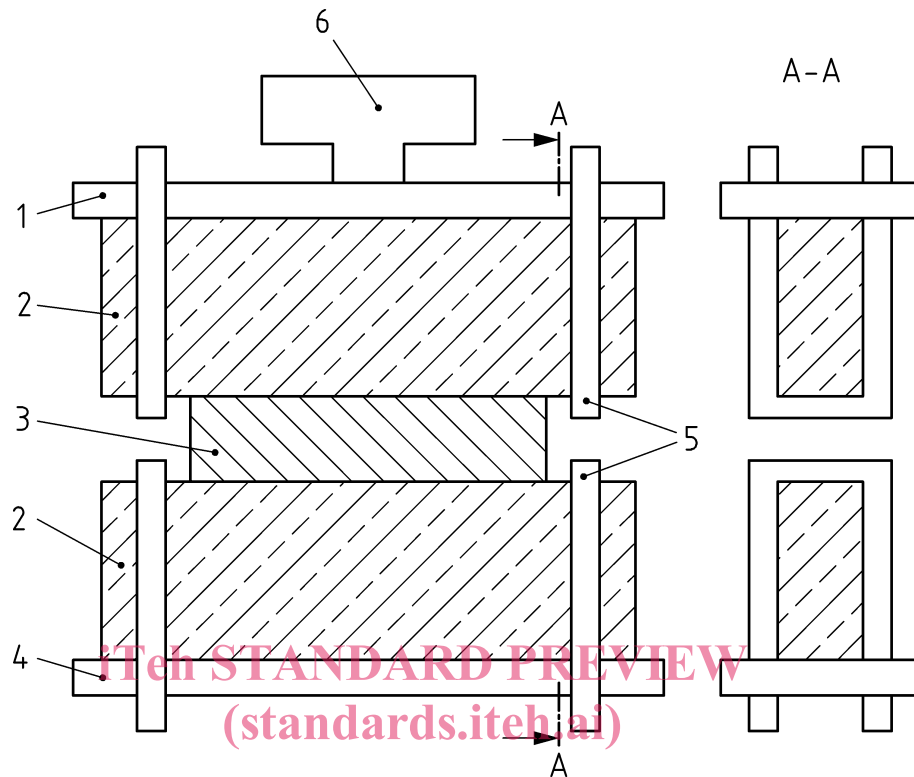

**Key**

- 1 Stationary beam
- 2 Concrete test blocks according to EN 13880-12
- 3 Sealant
- 4 Moveable beam
- 5 Grips
- 6 Load cell

SIST EN 14187-9:2006

<https://standards.iteh.ai/catalog/standards/sist/b7e02213-c5d4-4b9d-871c-60f0b1a5d4fe/sist-en-14187-9-2006>

**Figure 2 — Test specimen mounted in the test rig**