

---

---

**Textiles — Burning behaviour of bedding  
items —**

**Part 3:**

General test methods for the ignitability by  
a small open flame

iTeh STANDARD PREVIEW

*Textiles — Comportement au feu des articles de literie —*

*Partie 3: Méthodes d'essai générales pour l'allumabilité par une petite  
flamme nue*

[ISO 12952-3:1998](https://standards.iso.org/iso-12952-3-1998)

<https://standards.iteh.ai/catalog/standards/sist/30daaa48-8ee6-42ab-9b9f-6a3e0caa00d5/iso-12952-3-1998>



## Foreword

ISO (the International Organization for Standardization) is a worldwide federation of national standards bodies (ISO member bodies). The work of preparing International Standards is normally carried out through ISO technical committees. Each member body interested in a subject for which a technical committee has been established has the right to be represented on that committee. International organizations, governmental and non-governmental, in liaison with ISO, also take part in the work. ISO collaborates closely with the International Electrotechnical Commission (IEC) on all matters of electrotechnical standardization.

International Standards are drafted in accordance with the rules given in the ISO/IEC Directives, Part 3.

Draft International Standards adopted by the technical committees are circulated to the member bodies for voting. Publication as an International Standard requires approval by at least 75 % of the member bodies casting a vote.

Attention is drawn to the possibility that some of the elements of this part of ISO 12952 may be the subject of patent rights. ISO shall not be held responsible for identifying any or all such patent rights.

International Standard ISO 12952-3 was prepared by the European Committee for Standardization (CEN) in collaboration with ISO Technical Committee TC 38, *Textiles*, Subcommittee SC 19, *Burning behaviour of textiles and textile products*, in accordance with the Agreement on technical cooperation between ISO and CEN (Vienna Agreement).

Throughout the text of this standard, read “..this European Standard...” to mean “...this International Standard...”.

ISO 12952 consists of the following parts, under the general title *Textiles — Burning behaviour of bedding items*:

- *Part 1: General test methods for the ignitability by a smouldering cigarette*
- *Part 2: Specific test methods for the ignitability by a smouldering cigarette*
- *Part 3: General test methods for the ignitability by a small open flame*
- *Part 4: Specific test methods for the ignitability by a small open flame*

Annexes A and B of this part of ISO 12952 are for information only.

© ISO 1998

All rights reserved. Unless otherwise specified, no part of this publication may be reproduced or utilized in any form or by any means, electronic or mechanical, including photocopying and microfilm, without permission in writing from the publisher.

International Organization for Standardization  
Case postale 56 • CH-1211 Genève 20 • Switzerland  
Internet iso@iso.ch

Printed in Switzerland

## Contents

	Page
Foreword	iv
Introduction	iv
1 Scope	1
2 Normative references	1
3 Definitions	1
4 Principle	1
5 Criteria of ignition	2
6 Health and safety of operators	2
7 Apparatus	2
8 Cleaning	5
9 Atmospheres for conditioning and testing	5
10 Test specimens	5
11 Test procedures	6
12 Final examination	7
13 Test report	7
Annex A (informative) Preferred test report layout	8
Annex B (informative) Gas flow control recommended	9

ITC STANDARD PREVIEW  
(standards.iteh.ai)

[ISO 12952-3:1998](https://standards.iteh.ai/catalog/standards/sist/30daaa48-8ee6-42ab-9b9f-6a3e0caa00d5/iso-12952-3-1998)

<https://standards.iteh.ai/catalog/standards/sist/30daaa48-8ee6-42ab-9b9f-6a3e0caa00d5/iso-12952-3-1998>

## Foreword

The text of EN ISO 12952-3:1999 has been prepared by Technical Committee CEN/TC 248 "Textiles and textile products", the secretariat of which is held by BSI, in collaboration with Technical Committee ISO/TC 38 "Textiles".

This European Standard shall be given the status of a national standard, either by publication of an identical text or by endorsement, at the latest by July 1999, and conflicting national standards shall be withdrawn at the latest by July 1999.

According to the CEN/CENELEC Internal Regulations, the national standards organizations of the following countries are bound to implement this European Standard: Austria, Belgium, Czech Republic, Denmark, Finland, France, Germany, Greece, Iceland, Ireland, Italy, Luxembourg, Netherlands, Norway, Portugal, Spain, Sweden, Switzerland and the United Kingdom.

## Introduction

Fires are sometimes caused by the ignition of bedding items by smokers' materials; the ignitability of bedding items by a smouldering cigarette or a small open flame is therefore an important feature in the assessment of the risk of fire.

It cannot be assumed that protection against a smouldering ignition source will automatically give protection against flaming ignition. Users of this standard should, thus, consider the need to submit test specimens to both cigarette and flaming ignition tests.

EN ISO 12952-1 and EN ISO 12952-2 describe a method of test with the smouldering cigarette as ignition source. Testing against the ignition source of a small open flame forms the contents of EN ISO 12952-3 and EN ISO 12952-4.

This European Standard can be used for the assessment of ignitability of individual items of bedding and of composite arrangements.

EN ISO 12952-1 and EN ISO 12952-3 describe general testing procedure and aspects of testing common to all bedding items; EN ISO 12952-2 and EN ISO 12952-4 contain all details necessary for the testing of the specific bedding items.

**WARNING:** This test relates only to the ignitability of materials under the particular conditions of test. It is not intended as a means of assessing the full potential fire hazard of the bedding item in use.

Particular attention is drawn to the possibility of ignition of lower parts of a bedding assembly when using bedding items which are not themselves ignited.

## 1 Scope

This European Standard specifies a general test method common to all bedding items, for assessment of their ignitability when subjected to a smouldering cigarette.

EN ISO 12952-4 describes a specific test method for bedding items, which can normally be placed on a mattress, for example:

- mattress covers;
- underlays;
- incontinence-sheets and -pads;
- sheets;
- blankets;
- electric blankets;
- quilts (duvets) and covers;
- pillows (whatever the filling) and bolsters;
- pillowcases.

This standard does not apply to mattresses, bed-bases and mattress pads.

## 2 Normative references

This European Standard incorporates by dated or undated reference, provisions from other publications. These normative references are cited at the appropriate places in the text and the publications are listed hereafter. For dated references, subsequent amendments to or revisions of any of these publications apply to this draft European Standard only when incorporated in it by amendment or revision. For undated references the latest edition of the publication referred to applies.

EN ISO 12952-1	Textiles - Burning behaviour of bedding items - Part 1: General test methods for the ignitability by a smouldering cigarette (ISO 12952-1:1999)
EN ISO 12952-4	Textiles - Burning behaviour of bedding items - Part 4: Specific test methods for the ignitability by a small open flame (ISO 12952-4:1999)
EN ISO 3175	Textiles - Evaluation of stability to machine dry-cleaning (ISO 3175:1995)
ISO 26330	Textiles - Domestic washing and drying procedures for textile testing (ISO 6330:1984)
ISO/IEC GUIDE 52	Glossary of fire terms and definitions

## 3 Definitions

For the purposes of this standard, the definitions given in EN ISO 12952-1 apply.

## 4 Principle

A test specimen placed on a testing substrate is subjected to a small open flame placed on top of and/or below the test specimen (see EN ISO 12952-4). Any progressive smouldering and/or flaming is noted.

Where the actual mattress is known, it can replace the testing substrate.

## 5 Criteria of ignition

### 5.1 Progressive smouldering ignition

All the following types of behaviour given in a) to d) are considered to be progressive smouldering ignition:

- a) any test specimen that displays escalating combustion behaviour so that it is unsafe to continue the test and requires forcible extinction;
- b) any test specimen that smoulders until it is essentially consumed within the test duration;
- c) any test specimen that produces externally detectable amounts of smoke, heat or glowing after a period of 15 min following the removal of the ignition source;
- d) any test specimen that, on final examination, shows evidence of smouldering other than discolouration more than 100 mm in any horizontal direction from the nearest part of the original position of the ignition source.

NOTE: In practice, it has been found that there is usually a clear distinction between materials which char under the influence of an ignition source but which do not propagate further (non-progressive) and those where smouldering develops and spreads (progressive).

### 5.2 Flaming ignition

The following type of behaviour is considered to be flaming ignition:

- a) any test specimen that displays escalating combustion behaviour so that it is unsafe to continue the test and requires forcible extinction;
- b) any test specimen that continues to flame for more than 120 s after removal of the ignition source.

ITeB STANDARD PREVIEW

(standards.iteb.ai)

ISO 12952-3:1998

https://standards.iteb.ai/catalog/standards/sstd/368130000416-9000-12952-3

6a3e0caa00d5/iso-12952-3-1998

## 6 Health and safety of operators

There is considerable risk with these tests and it is essential that suitable precautions be taken, which can include the provision of breathing apparatus and protective clothing.

### 6.1 Enclosure

For safety, the tests shall be conducted in a suitable fume cupboard or purpose-built room so that individuals are not exposed to any fumes (see 7.4).

### 6.2 Extinguishers

Readily accessible suitable means of extinguishing the test specimens shall be provided. Extinction of test specimens can be difficult and care should be taken that they are only disposed of when completely inert. It can be necessary to immerse smouldering specimens in water, or place them in a sealed non-combustible enclosure. To ensure complete safety other suitable steps can be required.

## 7 Apparatus

### 7.1 Test rig

A suitable test rig is illustrated in figure 1. It consists of a platform of open mesh ( $400 \pm 50$ ) mm supported by a solid base. The test rig shall correspond to the dimensions of the test specimen, but can be larger than the test specimen.

The size of the mesh is not critical, nor are the angle iron dimensions given in figure 1. For the tests, the rig is placed within the test enclosure (see 7.4).

## 7.2 Clock

A stop clock reading to the nearest second and capable of measuring for at least 1 h.

## 7.3 Ignition source: propane gas flame

A burner tube consisting of stainless steel of  $(8,0 \pm 0,1)$  mm outside diameter,  $(6,5 \pm 0,1)$  mm internal diameter and  $(200 \pm 5)$  mm in length, is connected by flexible tubing via a flowmeter, fine control valve, on-off valve and cylinder regulator providing an outlet pressure of nominal  $2,8 \text{ kPa}^{1)}$  to a cylinder providing commercial propane.

The flowmeter shall be calibrated to supply a propane gas flow rate at  $25^\circ\text{C}$  of nominally  $(45 \pm 1)$  ml/min. The flexible tubing connecting the output of the flowmeter to the burner tube shall be 2,5 m to 3 m in length (see annex B).

NOTE: Under these conditions the flame height is approximately 35 mm.

## 7.4 Test enclosure

A suitable room with volume greater than  $20 \text{ m}^3$ , which contains adequate oxygen for testing, or a smaller enclosure with a throughflow of air equipped with inlet and extraction systems. Air flow rates shall not exceed 0,2 m/s in the locality of the test specimen position. This limit provides adequate oxygen without disturbing the burning behaviour.

## 7.5 Testing substrate

The testing substrate, which is used to simulate the mattress, over which the bedding items are tested, shall be a mineral wool fibre pad having a thermal conductivity of 0,04 W/m-K.

The nominal dimensions of the testing substrate are 450 mm x 450 mm x 25 mm thickness (see figure 2).

iteh STANDARD PREVIEW  
(standards.iteh.ai)

6a3e0caa00d5/iso-12952-3-1998

---

<sup>1)</sup> 1 kPa =  $1000 \text{ N/m}^2$  = 10 mbar

Dimensions in millimetres

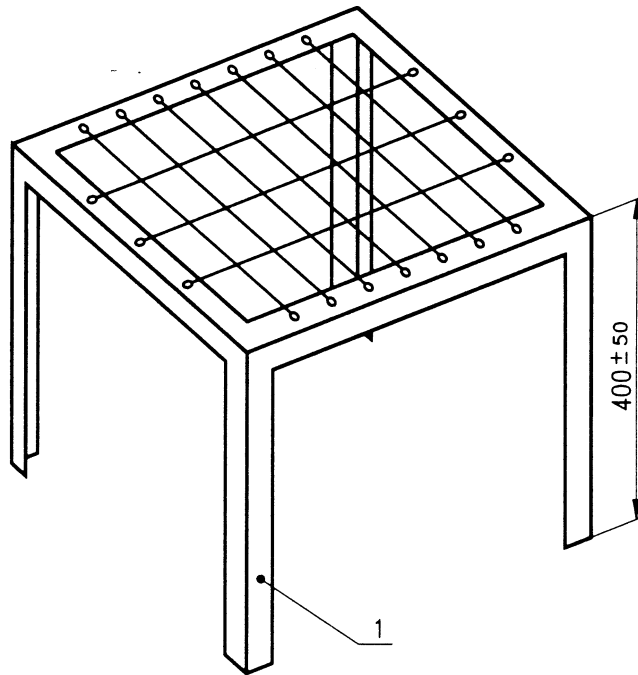

1) Nominal 25x25x3 angle iron

**iTeh STANDARD PREVIEW**  
**(standards.iteh.ai)**

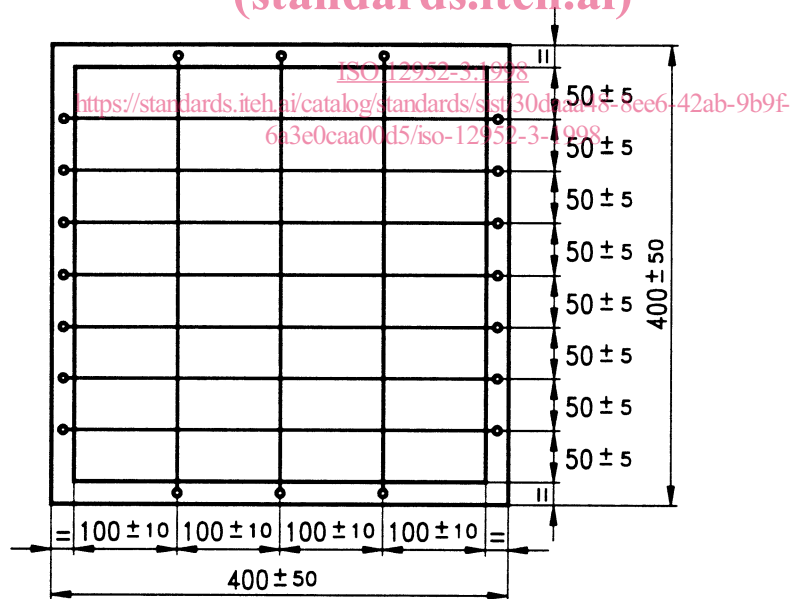

Figure 1 : Test rig



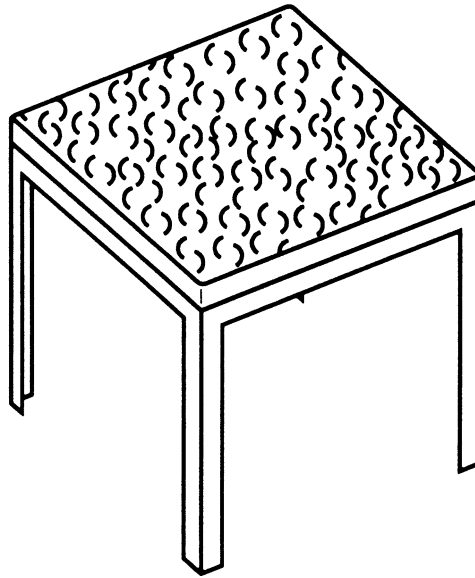

Figure 2 : Test rig with testing substrate

## 8 Cleaning

NOTE: Cleaning operations can have a considerable influence on the ignitability of bedding items. Bedding items that will normally undergo cleaning operations in use should therefore be tested also after an appropriate cleaning treatment.

Generally cleaning shall be carried out in agreement with the method specified by the producer of the bedding item. A cleaning specification can also be specified by the purchaser of the item (e.g. hospitals) or regulators (e.g. in the case of hotels).

If no cleaning procedure is specified, an appropriate method shall be chosen from either method 2A ISO 26330 or EN ISO 3175 and the method is indicated in the test report.

## 9 Atmospheres for conditioning and testing

### 9.1 Conditioning

The materials to be tested, as well as the testing substrate shall be conditioned immediately before the test for 72 h in indoor ambient conditions and then for at least 16 h in an atmosphere having a temperature of  $(20 \pm 2)^\circ\text{C}$  and a relative humidity of  $(65 \pm 5)\%$ .

### 9.2 Testing

For testing a draught-free environment having a temperature of  $15^\circ\text{C}$  to  $30^\circ\text{C}$  and a relative humidity of  $(55 \pm 20)\%$  shall be used. If the test is not carried out immediately after conditioning, place the conditioned specimens in a sealed container until the start of the test. Begin testing each test specimen within 10 min of removing it from the sealed container.

## 10 Test specimens

The test specimens shall be representative of the components and make-up of the finished item.