



SLOVENSKI STANDARD

SIST EN 1282-2:2005

01-september-2005

BUXca Yý U
SIST EN 1282-2:2000

Traheostomske cevke - 2. del: Cevke, ki se uporabljajo pri otrocih (ISO 5366-3:2001, spremenjen)

Tracheostomy tubes - Part 2: Paediatric tubes (ISO 5366-3:2001, modified)

Tracheotomietuben - Teil 2: Pädiatrische Tuben (ISO 5366-3:2001, geändert)

Tubes de trachéostomie - Partie 2: Tubes pédiatriques (ISO 5366-3:2001, modifiée)

<https://standards.iteh.ai/catalog/standards/sist/44d5f53b-de8e-47f9-aa96-78bc3db5ab0e/sist-en-1282-2-2005>

Ta slovenski standard je istoveten z: EN 1282-2:2005

ICS:

11.040.10	Anestezijska, respiratorna in reanimacijska oprema	Anaesthetic, respiratory and reanimation equipment
-----------	--	--

SIST EN 1282-2:2005

en

iTeh STANDARD PREVIEW
(standards.iteh.ai)

[SIST EN 1282-2:2005](https://standards.iteh.ai/catalog/standards/sist/44d5f53b-de8e-47f9-aa96-78bc3db5ab0e/sist-en-1282-2-2005)

<https://standards.iteh.ai/catalog/standards/sist/44d5f53b-de8e-47f9-aa96-78bc3db5ab0e/sist-en-1282-2-2005>

EUROPEAN STANDARD
NORME EUROPÉENNE
EUROPÄISCHE NORM

EN 1282-2

June 2005

ICS 11.040.10

Supersedes EN 1282-2:1997

English version

Tracheostomy tubes - Part 2: Paediatric tubes (ISO 5366-3:2001, modified)

Tubes de trachéostomie - Partie 2: Tubes pédiatriques (ISO 5366-3:2001, modifiée)

Tracheotomietuben - Teil 2: Pädiatrische Tuben (ISO 5366-3:2001, geändert)

This European Standard was approved by CEN on 25 April 2005.

CEN members are bound to comply with the CEN/CENELEC Internal Regulations which stipulate the conditions for giving this European Standard the status of a national standard without any alteration. Up-to-date lists and bibliographical references concerning such national standards may be obtained on application to the Central Secretariat or to any CEN member.

This European Standard exists in three official versions (English, French, German). A version in any other language made by translation under the responsibility of a CEN member into its own language and notified to the Central Secretariat has the same status as the official versions.

CEN members are the national standards bodies of Austria, Belgium, Cyprus, Czech Republic, Denmark, Estonia, Finland, France, Germany, Greece, Hungary, Iceland, Ireland, Italy, Latvia, Lithuania, Luxembourg, Malta, Netherlands, Norway, Poland, Portugal, Slovakia, Slovenia, Spain, Sweden, Switzerland and United Kingdom.

[SIST EN 1282-2:2005](https://standards.iteh.ai/catalog/standards/sist/44d5f53b-de8e-47f9-aa96-78bc3db5ab0e/sist-en-1282-2-2005)

<https://standards.iteh.ai/catalog/standards/sist/44d5f53b-de8e-47f9-aa96-78bc3db5ab0e/sist-en-1282-2-2005>



EUROPEAN COMMITTEE FOR STANDARDIZATION
COMITÉ EUROPÉEN DE NORMALISATION
EUROPÄISCHES KOMITEE FÜR NORMUNG

Management Centre: rue de Stassart, 36 B-1050 Brussels

Contents

Page

Foreword.....	3
Introduction.....	4
1 Scope	5
2 Normative references	5
3 Terms and definitions	5
4 Size designation and dimensions	6
4.1 Designation of size of tube	6
4.2 Outside diameter.....	6
4.3 Length.....	7
4.4 Angle θ	8
5 Materials	8
6 Design and finish.....	8
6.1 Machine end.....	8
6.2 Paediatric tracheostomy tube connector.....	8
6.3 Inner tube.....	9
6.4 Neck-plate.....	9
6.5 Cuff.....	9
6.6 Inflating tubes for cuffs.....	10
6.7 Patient end.....	10
6.8 Introducer	10
7 Requirements for tracheostomy tubes supplied sterile.....	10
7.1 Sterility assurance	10
7.2 Packaging for tracheostomy tubes supplied sterile	10
8 Marking	11
8.1 Marking of tracheostomy tube	11
8.2 Marking of tracheostomy tube connectors.....	11
8.3 Marking of unit packs.....	11
9 Adaptor	12
Annex A (normative) Test for security of attachment of permanently attached connector, if provided, and neck-plate to tracheostomy tube.....	13
A.1 Principle.....	13
A.2 Apparatus	13
A.3 Procedure	13
A.4 Expression of results	14
Annex B (normative) Test method for determining the resting diameter of the cuff	15
B.1 Principle.....	15
B.2 Apparatus	15
B.3 Procedure	15
B.4 Expression of results	15
Annex C (informative) Guidance on materials and design.....	16
C.1 Materials	16
C.2 Design	16
Annex ZA (informative) Relationship between this European Standard and the Essential Requirements of EU Directive 93/42/EEC Medical devices	17
Bibliography.....	19

Foreword

The text of the International Standard ISO 5366-3:2001, including Corrigendum 1:2003 from Technical Committee ISO/TC 121 “Anaesthetic and respiratory equipment” of the International Organization for Standardization (ISO) has been taken over as a European Standard by Technical Committee CEN/TC 215 “Respiratory and anaesthetic equipment”, the secretariat of which is held by BSI, with common modifications which are indicated by a straight line in the margin of the text.

This European Standard shall be given the status of a national standard, either by publication of an identical text or by endorsement, at the latest by December 2005 and conflicting national standards shall be withdrawn at the latest by December 2005.

This document supersedes EN 1282-2:1997.

This document has been prepared under a mandate given to CEN by the European Commission and the European Free Trade Association, and supports essential requirements of EU Directive(s).

For relationship with EU Directive(s), see informative Annex ZA, which is an integral part of this document.

According to the CEN/CENELEC Internal Regulations, the national standards organizations of the following countries are bound to implement this European Standard: Austria, Belgium, Cyprus, Czech Republic, Denmark, Estonia, Finland, France, Germany, Greece, Hungary, Iceland, Ireland, Italy, Latvia, Lithuania, Luxembourg, Malta, Netherlands, Norway, Poland, Portugal, Slovakia, Slovenia, Spain, Sweden, Switzerland and United Kingdom.

SIST EN 1282-2:2005

<https://standards.iteh.ai/catalog/standards/sist/44d5f53b-de8e-47f9-aa96-78bc3db5ab0e/sist-en-1282-2-2005>

EN 1282-2:2005 (E)**Introduction**

ISO 5366 is concerned with the basic requirements and method of size designation of tracheostomy tubes made of plastics materials and/or rubber.

EN ISO 5366-1 gives requirements for adult tracheostomy tubes made of plastics materials and/or rubber.

This document gives requirements for paediatric tracheostomy tubes with an inside diameter from 2,0 mm to 6,0 mm.

Paediatric tracheostomy tubes are primarily intended for use with infants and children who may require anaesthesia, artificial ventilation, relief of upper airway obstruction or other respiratory therapy.

An infant or child differs from an adult, not only in size but especially with regard to airway anatomy and respiratory physiology; thus airway equipment for paediatric patients differs from that for adults in size and also in basic design. It should be noted that, although this document gives some requirements for cuffs, cuffs are seldom provided on the smaller sizes of paediatric tubes.

This document gives requirements for those characteristics of tracheostomy tubes that can be standardized and which are important for patient safety. It does not require the connector to be permanently attached to the tube, as this may be impractical with infants and small children. Other acceptable methods of connecting these components are available, and this document makes provision for them. This document does not limit the range of tube designs needed to match the variety of paediatric anatomy, lesions and space limitations encountered.

The method of describing tube dimensions and configuration has been devised with the aim of assisting the clinician in the selection of a suitable tube to conform as far as possible to a particular patient's anatomy. Size is designated by inside diameter, which is important because of its relation to resistance to gas flow. Because the stomal and tracheal diameters are important when selecting tubes, it is considered essential that the outside diameter be stated for each size of tube.

<https://standards.iteh.ai/catalog/standards/sist/44d5f53b-de8e-47f9-aa96-30c0e3015c12/en-1282-2:2005>

A tracheostomy tube can increase resistance to gas flow. For tubes with a given outside diameter, differences in wall thickness have a major influence on the resistance to gas flow, especially in the smaller sizes of paediatric tracheostomy tubes.

Flammability of tracheostomy tubes, for example if flammable anaesthetics, electrosurgical units or lasers are used in oxidant-enriched atmospheres, is a well-recognized hazard¹ addressed by appropriate clinical management, which is outside the scope of this document.

¹See ISO/TR 11991.

1 Scope

This European Standard specifies requirements for paediatric tracheostomy tubes made of plastics materials and/or rubber having inside diameters from 2,0 mm to 6,0 mm. Requirements for paediatric tracheostomy tube connectors and adaptors are also given.

This document is not applicable to specialized tracheostomy tubes.

2 Normative references

The following referenced documents are indispensable for the application of this document. For dated references, only the edition cited applies. For undated references, the latest edition of the referenced document (including any amendments) applies.

EN 556-1:2001, *Sterilization of medical devices — Requirements for medical devices to be labelled “STERILE”*

EN ISO 5356-1, *Anaesthetic and respiratory equipment — Conical connectors — Part 1: Cones and sockets (ISO 5356-1:2004)*

EN ISO 5366-1:2004, *Anaesthetic and respiratory equipment — Tracheostomy tubes — Part 1: Tubes and connectors for use in adults (ISO 5366-1:2000)*

EN ISO 10993-1, *Biological evaluation of medical devices — Part 1: Evaluation and testing (ISO 10933-1:2003)*

EN 20594-1, *Conical fittings with a 6 % (Luer) taper for syringes, needles and certain other medical equipment — Part 1: General requirements*

ISO 5361, *Anaesthetic and respiratory equipment — Tracheal tubes and connectors*
<https://standards.iteh.ai/catalog/standards/sist/44d5f53b-de8e-47f9-aa96-78bc7db5ab0e/sist-en-1282-2-2005>

ISO 11607, *Packaging for terminally sterilized medical devices*

3 Terms and definitions

For the purposes of this European Standard, the terms and definitions given in EN ISO 5366-1:2004 and the following apply.

3.1

paediatric tracheostomy tube

tube designed for insertion into the trachea of an infant or child through a tracheostomy

3.2

paediatric tracheostomy tube connector

tubular component which fits directly into the paediatric tracheostomy tube

3.3

machine end

(paediatric tracheostomy tube connector) end of the component nearest the machine which is intended to mate with the breathing system of an anaesthetic machine or lung ventilator

3.4

patient end

(paediatric tracheostomy tube connector) end of the component nearest the patient which is inserted into the paediatric tracheostomy tube

EN 1282-2:2005 (E)

3.5

adaptor

specialized connector to establish functional continuity between otherwise disparate or incompatible components

4 Size designation and dimensions

4.1 Designation of size of tube

4.1.1 The size of a tracheostomy tube (outer tube) shall be designated by the nominal inside diameter (ID) of the tube expressed in millimetres, as measured at the minimum diameter, in accordance with Table 1, excluding any encroachment allowed by 6.6.1.

4.1.2 For tracheostomy tubes provided with an inner tube to which is attached an 8,5 mm or 15 mm male conical connector complying with the requirements of EN ISO 5356-1 [see 6.1 a)], the size shall be designated by the nominal inside diameter (ID) of the inner tube expressed in millimetres in accordance with Table 1.

Table 1 — Size designation, inside diameter and tolerances of paediatric tracheostomy tubes

Designated size	Inside diameter	Dimensions in millimetres
		Tolerance
2,0	2,0	+0,2
2,5	2,5	
3,0	3,0	
3,5	3,5	
4,0	4,0	
4,5	4,5	+ 0,3
5,0	5,0	
5,5	5,5	
6,0	6,0	

4.2 Outside diameter

4.2.1 The outside diameter (OD) of sections A and C (see Figure 1) of the tube, other than at the cuff if provided, shall be expressed in millimetres to the nearest 0,1 mm.

NOTE The marked outside diameter relates to that portion of the tube intended to be within the wall and lumen of the trachea.

4.2.2 The actual outside diameter of section A, other than at the cuff if provided, shall be the marked outside diameter subject to a tolerance of $\pm 0,2$ mm.

4.2.3 The actual outside diameter of section C shall be the marked outside diameter subject to a tolerance of $\pm 0,5$ mm.

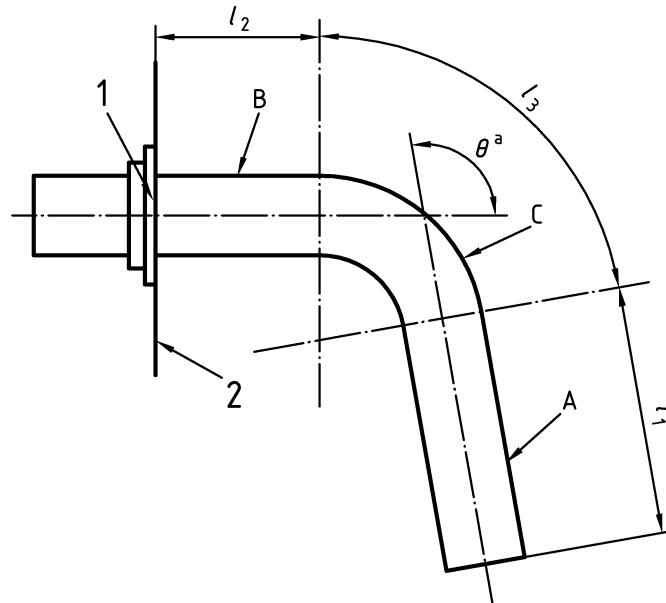

a) Paediatric tracheostomy tube

iTeh STANDARD PREVIEW
(standards.iteh.ai)

SIST EN 1282-2:2005

<https://standards.iteh.ai/catalog/standards/sist/44d5f53b-de8e-47f9-aa96-78bc3db5ab0e/sist-en-1282-2-2005>

b) Patient end

Key

- 1 Neck-plate
- 2 Datum plane
- 3 Tip rounded
- 4 Bevel, if present

^a Obtuse angle formed between the long axes of the tube at the machine and patient ends.

Figure 1 — Basic dimensions of paediatric tracheostomy tubes

4.3 Length

4.3.1 The nominal length ($l_1 + l_2 + l_3$ in Figure 1) shall be measured from the patient side of the neck-plate to the patient end, including the bevel if present (see Figure 1), and expressed in millimetres.

4.3.2 The actual nominal length ($l_1 + l_2 + l_3$ in Figure 1) shall be the marked nominal length subject to a tolerance of $\pm 1,5$ mm for tubes with a marked inside diameter of less than 4,5 mm, or subject to a tolerance of ± 2 mm for tubes with a marked inside diameter of 4,5 mm or greater.

EN 1282-2:2005 (E)

4.3.3 For tubes with an adjustable neck-plate, the range of measurements for nominal length (see Figure 1) shall be expressed in millimetres.

4.3.4 Dimensions l_1 , l_2 and l_3 shall be expressed in millimetres [see Figure 1 a)].

NOTE Dimensions l_1 and/or l_2 can be, or approach, zero.

4.4 Angle θ

The angle θ (see Figure 1) shall be expressed in degrees.

5 Materials

Tracheostomy tubes, including cuffs and tracheostomy tube connectors provided with the tube, in their ready-for-use state after any preparation for use recommended by the manufacturer, shall satisfy appropriate biological safety testing, as indicated in EN ISO 10993-1.

NOTE See Annex C for guidance on materials and design.

6 Design and finish**6.1 Machine end**

The machine end of a paediatric tracheostomy tube shall

a) have a permanently attached 8,5 mm or 15 mm male conical connector complying with the requirements of EN ISO 5356-1, or

NOTE In this context, permanently attached means it does not become detached when subject to the forces described in the test method given in Annex A.

b) accept a paediatric tracheostomy tube connector in accordance with 6.2 or

c) mate with an adaptor in accordance with Clause 9.

6.2 Paediatric tracheostomy tube connector

6.2.1 The nominal size of a paediatric tracheostomy tube connector shall be designated by its inside diameter in accordance with Table 2.

NOTE A connector is intended to fit a tracheostomy tube of the same designated size.

6.2.2 The connector supplied with a tracheostomy tube shall have an inside diameter not less than the inside diameter of that tube as stated by the manufacturer [see 8.1 a)].

Table 2 — Size designation, inside diameter and tolerances of paediatric tracheostomy tube connectors

	Dimensions in millimetres
Designated size	Inside diameter of patient end $\pm 0,15$
2,0	2,0
2,5	2,5
3,0	3,0
3,5	3,5
4,0	4,0
4,5	4,5
5,0	5,0
5,5	5,5
6,0	6,0

iTeh STANDARD PREVIEW
(standards.iteh.ai)

6.2.3 The machine end shall be an 8,5 mm or 15 mm male conical connector complying with EN ISO 5356-1. The inside diameter of the conical connector at the machine end shall be not less than that allowed by Table 2 for the patient end.

[SIST EN 1282-2:2005](https://standards.iteh.ai/catalog/standards/sist/44d5f53b-de8e-47f9-aa96-)

<https://standards.iteh.ai/catalog/standards/sist/44d5f53b-de8e-47f9-aa96->

6.2.4 Any transition from one inside diameter to another shall be tapered to give an adequate lead-in for passage of a suction catheter.

6.3 Inner tube

6.3.1 The inner tube, if provided with the outer tube, shall extend to within 1,0 mm of the patient end of the tracheostomy (outer) tube and not more than 1,0 mm beyond the patient end.

6.3.2 The machine end of the inner tube shall either comply with 6.1 or shall not prevent the tracheostomy (outer) tube connector or adaptor, if provided, mating with the breathing system of an anaesthetic machine or lung ventilator.

6.4 Neck-plate

6.4.1 Tracheostomy tubes shall have a neck-plate that shall be either adjustable or permanently attached to the tube.

6.4.2 The neck-plate shall be provided with holes or other means to permit attachment to the patient.

6.4.3 If a tracheostomy tube has an adjustable neck-plate, it shall be securable to the tube (but see C.2.4).

6.4.4 When tested in accordance with Annex A, the neck-plate shall not move longitudinally relative to the tube.

6.5 Cuff

6.5.1 A cuff, if provided, shall be permanently attached to the tube.

6.5.2 Cuffs of tracheostomy tubes shall satisfy the requirements of ISO 5361.