



SLOVENSKI STANDARD
SIST EN 1820:2005

01-september-2005

BUXca Yý U
SIST EN 1820:2000

Dihalni baloni (ISO 5362:2000, spremenjen)

Anaesthetic reservoir bags (ISO 5362:2000, modified)

Anästhesie-Reservoirbeutel (ISO 5362:2000, geändert)

Ballons réservoirs d'anesthésie (ISO 5362:2000, modifiée)

[SIST EN 1820:2005](#)

<https://standards.iteh.ai/catalog/standards/sist/cbed4fc4-23fa-4efe-8f8b-742/sist-en-1820-2005>

Ta slovenski standard je istoveten z: EN 1820:2005

ICS:

11.040.10	Anestezijska, respiratorna in reanimacijska oprema	Anaesthetic, respiratory and reanimation equipment
-----------	--	--

SIST EN 1820:2005

en

iTeh STANDARD PREVIEW
(standards.iteh.ai)

[SIST EN 1820:2005](#)

<https://standards.iteh.ai/catalog/standards/sist/cbed4fc4-23fa-4efe-8f8b-66bf44dca742/sist-en-1820-2005>

EUROPEAN STANDARD
NORME EUROPÉENNE
EUROPÄISCHE NORM

EN 1820

June 2005

ICS 11.040.10

Supersedes EN 1820:1997

English version

Anaesthetic reservoir bags (ISO 5362:2000, modified)

Ballons réservoirs d'anesthésie (ISO 5362:2000, modifiée)

Anästhesie-Reservoirbeutel (ISO 5362:2000, geändert)

This European Standard was approved by CEN on 25 April 2005.

CEN members are bound to comply with the CEN/CENELEC Internal Regulations which stipulate the conditions for giving this European Standard the status of a national standard without any alteration. Up-to-date lists and bibliographical references concerning such national standards may be obtained on application to the Central Secretariat or to any CEN member.

This European Standard exists in three official versions (English, French, German). A version in any other language made by translation under the responsibility of a CEN member into its own language and notified to the Central Secretariat has the same status as the official versions.

CEN members are the national standards bodies of Austria, Belgium, Cyprus, Czech Republic, Denmark, Estonia, Finland, France, Germany, Greece, Hungary, Iceland, Ireland, Italy, Latvia, Lithuania, Luxembourg, Malta, Netherlands, Norway, Poland, Portugal, Slovakia, Slovenia, Spain, Sweden, Switzerland and United Kingdom.

(standards.iteh.ai)

SIST EN 1820:2005

<https://standards.iteh.ai/catalog/standards/sist/cbed4fc4-23fa-4efe-8f8b-66bf44dca742/sist-en-1820-2005>



EUROPEAN COMMITTEE FOR STANDARDIZATION
COMITÉ EUROPÉEN DE NORMALISATION
EUROPÄISCHES KOMITEE FÜR NORMUNG

Management Centre: rue de Stassart, 36 B-1050 Brussels

Contents	Page
Foreword.....	4
Introduction	5
1 Scope	6
2 Normative references	6
3 Terms and definitions	6
4 General requirements.....	7
5 Prevention of electrostatic charges.....	9
6 Requirements for bags supplied sterile	9
7 Marking	9
8 Information to be supplied by the manufacturer.....	10
Annex A (informative) Test for leakage	11
A.1 Principle	11
A.2 Apparatus.....	11
A.3 Procedure.....	11
A.4 Expression of results.....	11
Annex B (normative) Determination of capacity.....	12
B.1 Principle	12
B.2 Apparatus.....	12
B.3 Procedure.....	12
B.4 Expression of results.....	12
Annex C (normative) Test for security of attachment of plain neck to 22 mm male conical connector	13
C.1 Principle	13
C.2 Apparatus and materials	13
C.3 Procedure.....	13
Annex D (normative) Test for security of attachment of adaptor of assembled neck to bag.....	14
D.2 Apparatus.....	14
D.3 Procedure.....	14
Annex E (normative) Test for resistance to pressure required to distend the bag (pressure/volume) ..	15
E.1 Principle	15
E.2 Apparatus	15
E.3 Procedure.....	15
E.4 Expression of results	15
Annex F (informative) Test for resistance to pressure required to distend the bag using air (pressure/volume).....	16
F.1 Principle.....	16
F.2 Apparatus	16

F.3 Procedure	16
F.4 Expression of results	16
Annex G (informative) Recommendations for materials	17
Annex ZA (informative) Relationship between this European Standard and the Essential Requirements of EU Directive 93/42/EEC Medical devices	18
Bibliography	20

iTeh STANDARD PREVIEW (standards.iteh.ai)

[SIST EN 1820:2005](https://standards.iteh.ai/catalog/standards/sist/cbed4fc4-23fa-4efe-8f8b-66bf44dca742/sist-en-1820-2005)

<https://standards.iteh.ai/catalog/standards/sist/cbed4fc4-23fa-4efe-8f8b-66bf44dca742/sist-en-1820-2005>

Foreword

The text of the International Standard ISO 5362:2000 from Technical Committee ISO/TC121 “Anaesthetic and respiratory equipment” of the International Organization for Standardization (ISO) has been taken over as a European Standard by Technical Committee CEN/TC 215 “Respiratory and anaesthetic equipment”, the secretariat of which is held by BSI, with common modifications which are indicated by a straight line in the margin of the text.

This European Standard shall be given the status of a national standard, either by publication of an identical text or by endorsement, at the latest by December 2005 and conflicting national standards shall be withdrawn at the latest by December 2005. This document supersedes EN 1820:1997.

This document has been prepared under a mandate given to CEN by the European Commission and the European Free Trade Association, and supports essential requirements of EU Directive(s).

For relationship with EU Directive(s), see informative Annex ZA, which is an integral part of this document.

According to the CEN/CENELEC Internal Regulations, the national standards organizations of the following countries are bound to implement this European Standard: Austria, Belgium, Cyprus, Czech Republic, Denmark, Estonia, Finland, France, Germany, Greece, Hungary, Iceland, Ireland, Italy, Latvia, Lithuania, Luxembourg, Malta, Netherlands, Norway, Poland, Portugal, Slovakia, Slovenia, Spain, Sweden, Switzerland and United Kingdom.

iTeh STANDARD PREVIEW
(standards.iteh.ai)

SIST EN 1820:2005

<https://standards.iteh.ai/catalog/standards/sist/cbed4fc4-23fa-4efe-8f8b-66bf44dca742/sist-en-1820-2005>

Introduction

This European Standard is one of a series dealing with anaesthetic and respiratory equipment. This document is primarily concerned with the design of the neck, size designation and resistance to pressure required to distend anaesthetic reservoir bags.

The requirement that reservoir bags should be electrically conductive when used with a flammable anaesthetic is widely recognized and is of particular importance when such bags are rhythmically compressed by the anaesthetic provider in order to provide intermittent positive-pressure ventilation.

This European Standard gives requirements for both antistatic and non-antistatic bags. Only antistatic bags are suitable for use with flammable anaesthetic agents.

This European Standard includes requirements for both single-use and reusable bags. Reusable bags are intended to comply with the requirements of this document for the recommended product life.

The reference test method given as Annex E is not practical for routine use in manufacturing control, because it involves filling the bag with water. For this reason, another test method using air rather than water has been provided for information in Annex F. This may ultimately be suitable as the reference test method if it can be shown to give results equivalent to Annex E.

A test method for leakage of bags using air rather than water is given as Annex A for information only. Recommendations for materials are given in Annex G.

iTeh STANDARD PREVIEW (standards.iteh.ai)

[SIST EN 1820:2005](https://standards.iteh.ai/catalog/standards/sist/cbed4fc4-23fa-4efe-8f8b-66bf44dca742/sist-en-1820-2005)

<https://standards.iteh.ai/catalog/standards/sist/cbed4fc4-23fa-4efe-8f8b-66bf44dca742/sist-en-1820-2005>

EN 1820:2005 (E)**1 Scope**

This European Standard specifies requirements for antistatic and non-antistatic reservoir bags for use with anaesthetic apparatus or lung-ventilator breathing systems. It includes requirements for the design of the neck, size designation, distension and, where relevant, for electrical resistance.

This document is not applicable to special-purpose bags, for example bellows and self-expanding bags. Bags for use with anaesthetic gas scavenging systems are not considered to be anaesthetic reservoir bags and are thus outside the scope of this document.

2 Normative references

The following referenced documents are indispensable for the application of this document. For dated references, only the edition cited applies. For undated references, the latest edition of the referenced document (including any amendments) applies.

EN 556-1:2001, *Sterilization of medical devices — Requirements for medical devices to be labelled “STERILE”*

EN 980, *Graphical symbols for use in the labelling of medical devices*

EN 60601-1:1990, *Medical electrical equipment — Part 1: General requirements for safety (IEC 60601-1:1988)*

EN ISO 4287, *Geometrical product specifications (GPS) — Surface texture: Profile method — Terms, definitions and surface texture parameters (ISO 4287:1997)*

EN ISO 5356-1, *Anaesthetic and respiratory equipment — Conical connectors — Part 1: Cones and sockets (ISO 5356-1:2004)*

ISO 7000, *Graphical symbols for use on equipment — Index and synopsis*

ISO 11607, *Packaging for terminally sterilized medical devices*

3 Terms and definitions

For the purposes of this European Standard, the following terms and definitions apply.

3.1**anaesthetic reservoir bag**

collapsible gas container which is a component in a breathing system

[EN ISO 4135:—]

3.2**assembled neck**

neck incorporating an adaptor

3.3**adaptor**

specialized connector to establish functional continuity between otherwise disparate or incompatible components, one end of which is intended to be inserted into the neck of the bag, the other end having a conical connector complying with EN ISO 5356-1

3.4**plain neck**

neck designed to fit directly over a male conical connector complying with EN ISO 5356-1

3.5

tail

tubular extension of the bag at the end opposite to the neck

4 General requirements

4.1 Reusable bags

Reusable bags shall comply with the requirements of this document throughout the recommended product life as given in Clause 8.

4.2 Size designation

The size of the bag shall be designated by the nominal capacity expressed in litres.

4.3 Leakage

Bags of nominal capacity 1 l or less shall not leak at a rate of more than $10 \text{ ml}\cdot\text{min}^{-1}$ at an internal overpressure of $(3 \pm 0,3) \text{ kPa}$.

Bags of nominal capacity greater than 1 l shall not leak at a rate of more than $25 \text{ ml}\cdot\text{min}^{-1}$ at an internal overpressure of $(3 \pm 0,3) \text{ kPa}$.

NOTE 1 For the purpose of this document, the flowrate of air required to maintain the specified internal gas pressure is assumed to equal the leakage rate.

NOTE 2 A suitable test method is given in Annex A. This draws attention to the possible sites of leakage.

4.4 Capacity

The actual capacity of the bag when tested in accordance with Annex B shall be the marked value, subject to a tolerance of $\pm 15 \%$.

4.5 Design

4.5.1 Neck

4.5.1.1 Necks shall be either plain or assembled.

4.5.1.2 Plain necks shall fit directly on to 22 mm male conical connectors complying with EN ISO 5356-1, or on to adaptors that fit 8,5 mm, 15 mm or 22 mm male conical connectors complying with EN ISO 5356-1.

NOTE Plain necks may be reinforced internally or externally or made of a material thicker than that of the bag.

4.5.1.3 Plain necks of bags intended to fit directly on to 22 mm male conical connectors shall have an axial length of not less than 26 mm from the open end, when measured in the unstretched condition. Plain necks shall not become detached from a 22 mm male conical connector when tested in accordance with Annex C.

NOTE Plain necks may be constructed to engage with the recess at the base of a 22 mm male conical connector.

4.5.1.4 Assembled necks shall incorporate an adaptor (see Figure 1) bearing a female conical connector in accordance with EN ISO 5356-1. The adaptor of the assembled neck shall not become detached from the bag when tested in accordance with Annex D.

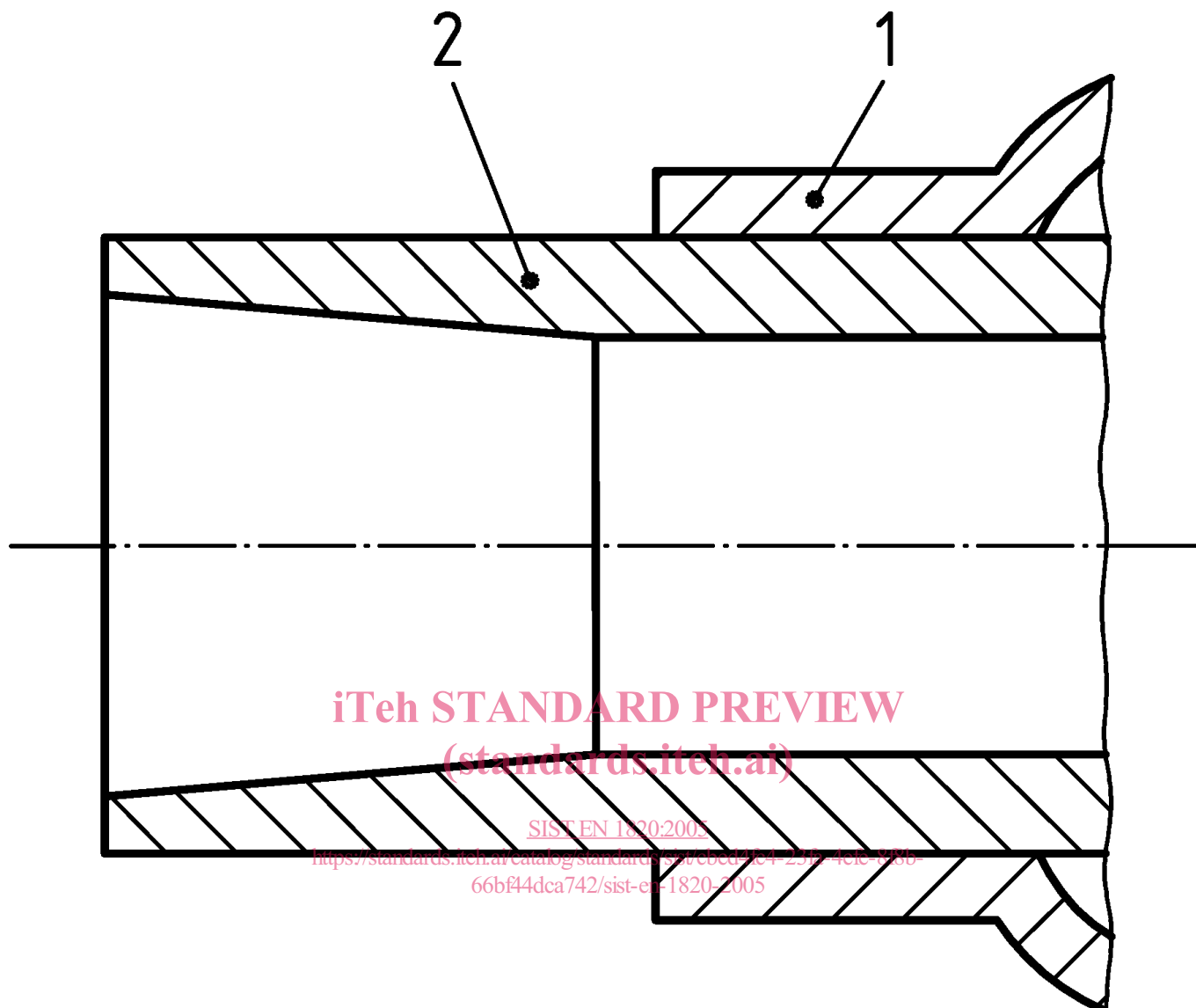

Key

- 1 Neck of reservoir bag
- 2 Adaptor, which may be flanged, grooved or recessed

Figure 1—Typical adaptor with (female) conical connector

4.5.2 Tail

The tail, if open and not provided with a closure mechanism, shall have a minimum length of 20 mm.

NOTE A loop for suspending the bag may be provided near the tail of the bag.

4.6 Resistance to pressure required to distend the bag (pressure/volume)

4.6.1 When tested in accordance with Annex E (see E.3.6), the final pressure head shall be not less than 3,0 kPa and not more than 6,0 kPa.

4.6.2 A bag tested in accordance with Annex E shall revert within 30 min of the test to its previously measured capacity (i.e. capacity V_1 , see E.3.2) within a tolerance of $\pm 10\%$.

NOTE Another method for testing resistance to pressure to distend the bag, involving filling the bag with air rather than water, has been included for information as Annex F.

5 Prevention of electrostatic charges

5.1 Antistatic bags shall comply with the requirements specified in EN 60601-1:1990, 39.3b.

5.2 Bags coloured black shall be antistatic and comply with 5.1.

6 Requirements for bags supplied sterile

6.1 Sterility assurance

Bags supplied and marked as “STERILE” shall satisfy the requirements of EN 556-1:2001, 4.1.

6.2 Packaging for bags supplied sterile

Each bag supplied and marked as “STERILE” shall be contained in an individual pack. The pack shall serve as an effective barrier to the penetration of microorganisms and particulate material in accordance with ISO 11607. The pack shall permit the extraction of the contents and shall not be capable of reclosure without clearly revealing that it has been opened.

NOTE The individual pack may also contain other breathing system components.

STANDARD PREVIEW
(standards.iteh.ai)

7 Marking

SIST EN 1820:2005

7.1 Use of symbols <https://standards.iteh.ai/catalog/standards/sist/cbed4fc4-23fa-4efe-8f8b-66bf44dca742/sist-en-1820-2005>

The requirements of 7.2 and 7.3 may be met by the use of appropriate symbols as given in ISO 7000 or EN 980.

7.2 Reusable bags

Bags intended for reuse shall be marked with the following information:

- a) the name or trade mark of the manufacturer and/or supplier;
- b) the nominal capacity (see 4.2);
- c) for bags and integrally attached non-metallic components for use with flammable anaesthetic agents, the word “ANTISTATIC”.

It is recommended that reservoir bags be additionally marked with the “use-by” date.

The marking should be legible, durable and resistant to the methods of cleaning and disinfection or sterilization recommended by the manufacturer.

NOTE Reusable bags may be black or coloured and/or bear an indelible yellow-coloured marking.

7.3 Single-use bags

The packaging or an insert shall be marked in accordance with 7.2 and with the words “single use” or equivalent.

An indication shall be given if any natural rubber (latex) is present in the device.

NOTE Single-use bags may be black or coloured and/or bear an indelible yellow-coloured marking.