



Designation: C 1053 – 00

# Standard Specification for Borosilicate Glass Pipe and Fittings for Drain, Waste, and Vent (DWV) Applications<sup>1</sup>

This standard is issued under the fixed designation C 1053; the number immediately following the designation indicates the year of original adoption or, in the case of revision, the year of last revision. A number in parentheses indicates the year of last reapproval. A superscript epsilon ( $\epsilon$ ) indicates an editorial change since the last revision or reapproval.

*This standard has been approved for use by agencies of the Department of Defense.*

## 1. Scope

1.1 This specification covers chemically resistant, low expansion, Type I, borosilicate glass, Class A (see Specification E 438), used to manufacture corrosion-resistant pipe and fittings for drain, waste, and vent service.

1.2 The pipe and fittings covered by the specification are intended for chemical resistant service above and below grade under gravity flow or vacuum conditions.

1.3 The pipe and fittings shall have beaded or plain ends.

## 2. Referenced Documents

### 2.1 ASTM Standards:

C 600 Method of Thermal Shock Test on Glass Pipe<sup>2</sup>

C 623 Test Method for Young's Modulus, Shear Modulus, and Poisson's Ratio for Glass and Glass-Ceramics by Resonance<sup>2</sup>

C 693 Test Method for Density of Glass by Buoyancy<sup>2</sup>

E 438 Specification for Glasses in Laboratory Apparatus<sup>3</sup>

## 3. Ordering Information

3.1 The minimum ordering information for material under this specification shall include the following information:

3.1.1 ASTM designation and date of issue,

3.1.2 Manufacturer's catalog number or parts identification,

3.1.3 Quantity ordered,

3.1.4 Special test or certification requirements,

3.1.5 Special packaging or marking, if required, and

3.1.6 Accessory items such as couplings, drains, adapters, and cutters.

## 4. Materials and Manufacture

4.1 The glass components shall represent good workmanship as consistent with standard glass process capabilities.

## 5. Chemical Requirements

5.1 The chemical requirements shall be as described in Specification E 438.

## 6. Physical Requirements

6.1 The physical requirements shall be as described in Specification E 438.

6.2 Refer also to Annex A1 for additional physical requirements.

## 7. Operating Temperatures

7.1 *Minimum Operating Temperature*—The minimum rated operating temperature for all sizes shall be  $-40^{\circ}\text{F}$  ( $-40^{\circ}\text{C}$ ) provided the material being conveyed is fluid.

7.2 *Maximum Operating Temperature*—The maximum rated continuous operating temperature shall be  $212^{\circ}\text{F}$  ( $100^{\circ}\text{C}$ ).

7.3 *Thermal Shock Resistance*—The maximum allowable temperature differential for installed systems shall be in accordance with Table 1 for the various pipe sizes. Maximum temperature differential refers to an almost instantaneous temperature change, such as low-pressure steam followed directly by a flush of ice cold water, or the reverse. Maximum temperature differential pertains to either inside or outside pipe surfaces.

7.3.1 Thermal shock resistance is not ordinarily tested. If thermal shock resistance may be questioned, it shall be tested in accordance with Method C 600. If all pieces tested pass the allowable temperature differential, the lot shall be accepted. If one or more failures occur, a retest shall be made using a sample size twice that of the first test. If any failures occur on the retest, the entire shipment shall be retested.

## 8. Pressure Rating

8.1 DWV piping systems are designed for gravity flow only.

8.2 All pipe sizes are suitable for vacuum service.

## 9. Dimensions and Permissible Variations

9.1 *Beaded Flanges*:

<sup>1</sup> This specification is under the jurisdiction of ASTM Committee C-14 on Glass and Glass

Products and is the direct responsibility of Subcommittee C14.05 on Glass Pipe. Current edition approved April 10, 2000. Published September 2000. Originally published as C 1053 – 85. Last previous edition C 1053 – 90 (1995)<sup>\epsilon</sup>1.

<sup>2</sup> *Annual Book of ASTM Standards*, Vol 15.02.

<sup>3</sup> *Annual Book of ASTM Standards*, Vol 14.04.

**TABLE 1 Maximum Temperature Differential for Thermal Shock**

Pipe Size, in. (mm)	Sudden Temperature Difference, Max °F (°C)
1½–3 (38–76)	200 (93)
4 (102)	175 (78)
6 (152)	160 (71)

9.1.1 *Flange Face Flatness*—Maximum permissible deviation from a flat plane across the face of a flange on all sizes shall be 1/16 in. (1.6 mm).

9.1.2 *Flange Face Squareness*—Flange faces of both pipe and fittings shall be square to the pipe centerline within the limits prescribed in Table 2.

9.1.2.1 Squareness of straight pipe lengths shall be measured by placing the pipe on rollers, located approximately 2 in. (51 mm) from each end, and butting one end against a flat plate perpendicular to the axis of the rollers. The pipe shall be rotated and length variation read with a suitable mechanism, such as a dial indicator. The maximum reading shall not exceed that shown in Table 2 for the respective pipe size.

9.1.2.2 Pipe fittings shall be measured for flange squareness by a gage having flat plates constructed at the angle required by that fitting. One flange shall be firmly placed on one plate, and any difference between the remaining flange face and the other surface plate shall be measured with Feller gages. Differences shall not exceed the amount shown in Table 2 for the respective fitting size.

9.1.3 *Flange Dimensions and Specifications*—Beaded flange dimensions shall be as required by the manufacturer for the system.

9.2 *Bow:*

9.2.1 *Bow for All Pipe Diameters*—Bow shall be measured by supporting the pipe in “V” blocks approximately 2 in. from each end with a dial gage at midlength, rotating the pipe full 360°. The total dial deflection divided by two is the measure of bow, which shall not exceed 0.25 % of the pipe length.

9.3 *Dimensions of All Pipe and Fittings:*

9.3.1 Dimensional specifications for pipe and common fittings shall be as shown in the manufacturer’s literature. Typical configurations are as illustrated in Figs. 1-45.

**10. Inspection**

10.1 Inspection of the material shall be made at the point of delivery unless otherwise agreed upon by the purchaser and the seller.

**11. Packaging**

11.1 Pipe, fittings, and hardware shall be so packaged as to prevent damage during transportation and handling. Those

**TABLE 2 Flange Face Squareness**

Nominal Pipe Size, in.	Squareness Measurement, Max, in.
1½ to 2	1/32
3	3/64
4	1/16
6	5/64

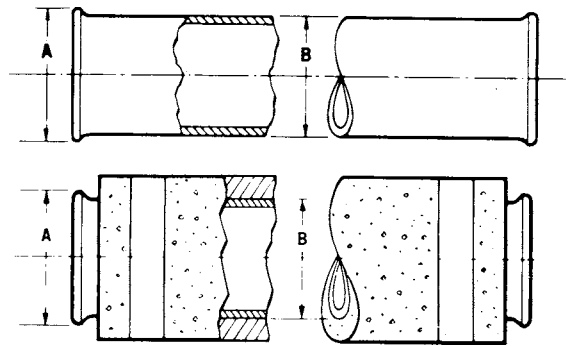

Size, in.	A (OD)		Wall Thickness, in.	Length, ft <sup>A</sup>
	Diameter, in.	Diameter, in.		
1½	2.06	1.84	0.17	5 and 10
2	2.58	2.34	0.17	5 and 10
3	3.69	3.41	0.20	5 and 10
4	4.84	4.53	0.27	5 and 10
6	7.12	6.66	0.33	5 and 10

<sup>A</sup>Length includes coupling allowance.

Nominal OD Over EPS<sup>A</sup>

1½ in.	2 13/16
2 in.	3 5/16
3 in.	5
4 in.	6 1/4
6 in.	8 9/16

<sup>A</sup>Pipe with EPS (expanded polystyrene) covering for underground service; lengths of 5 ft only.

**FIG. 1 Standard Specifications for Straight Lengths of Pipe**

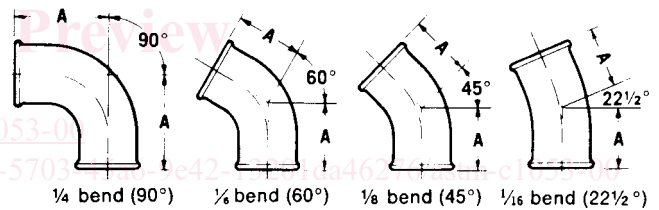

Size	A Dimension <sup>A</sup> , in.			
	90°	60°	45°	22½°
1½	3	2½	2	—
2	3¼	2¾	2¼	2¼
3	5	3½	2¾	2¾
4	7	4½	3¼	3¼
6	—	—	7	—

<sup>A</sup>Dimensions to beaded flanges include coupling allowance.

**FIG. 2 Elbows**

items packed in containers conforming to all construction requirements of consolidated freight classification as to bursting tests, size limit, and gross mass shall be considered as being properly packed.

11.2 All hardware items shall be packed in such a way as to prevent contact with glass components. Some typical hardware items are shown in Appendix X1.

**12. Keywords**

12.1 borosilicate; components; fittings; glass; pipe

**LONG 90°**

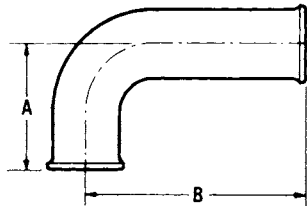

Size	A	B
1½-90°	3¾	6
2-90°	3¾	7½

**FIG. 3 Elbow**

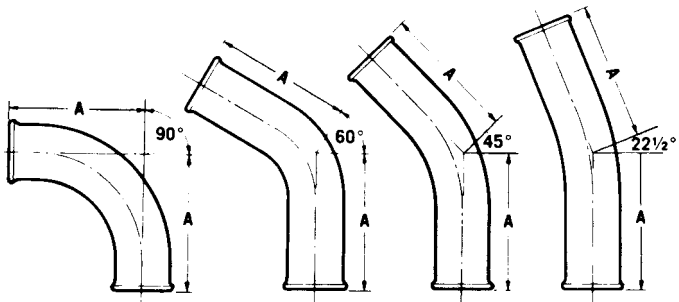

¼ bend (90°)    ¼ bend (60°)    ⅓ bend (45°)    ⅓ bend (22½°)  
A Dimensions<sup>A</sup>, in.

Size	90°	60°	45°	22½°
1½	4½	4½	4½	4½
2	5	5	5	5
3	6½	6½	6½	6½
4	9	9	9	9
6	12	12	12	12

<sup>A</sup>Dimensions to beaded flanges include coupling allowance.

**FIG. 4 Sweep Elbows**

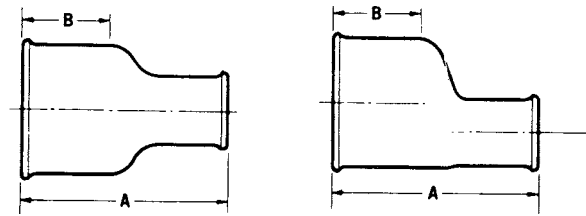

Dimensions<sup>A</sup>, in.

Size	A	B (min)
2 by 1½	4	1¾
3 by 1½	5	2¼
3 by 2	5	2¼
4 by 1½	7	3
4 by 2	7	3
4 by 3	7	3
6 by 1½	9	4
6 by 2	9	4
6 by 3	9	4
6 by 4	9	4

<sup>A</sup>Dimensions to beaded flanges include coupling allowance.

**FIG. 6 Straight Reducers and Eccentric Reducers**

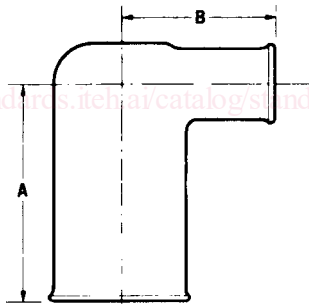

Dimensions<sup>A</sup>, in.

Size	A	B
2 by 1½	4	3½
3 by 1½	5	4
3 by 2	5	4½
4 by 1½	7	4½
4 by 2	7	5
4 by 3	7	5½
6 by 1½	9	5½
6 by 2	9	6
6 by 3	9	6½
6 by 4	9	8

<sup>A</sup>Dimensions to beaded flanges include coupling allowance.

**FIG. 5 Quarter Bend Reducer**

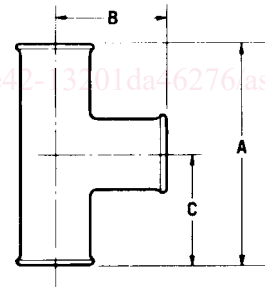

Dimensions<sup>A</sup>, in.

Size	A	B	C
1½ by 1½	6	3	3
2 by 1½	8	3¼	4
2 by 2	8	4	4
3 by 1½	12	4½	6
3 by 2	12	4½	6
3 by 3	12	6	6
4 by 1½	14	5	7
4 by 2	14	5	7
4 by 3	14	6½	7
4 by 4	14	8	7
6 by 3	20	7¾	10
6 by 4	20	9	10
6 by 6	20	10	10

<sup>A</sup>Dimensions to beaded flanges include coupling allowance.

**FIG. 7 Straight T**

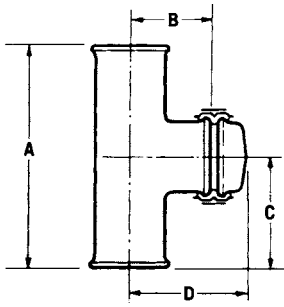

Size	A	B	C	D
1½ x 1½	6	2 <sup>3</sup> / <sub>16</sub>	3	3 <sup>1</sup> / <sub>16</sub>
2 x 2	8	2 <sup>11</sup> / <sub>16</sub>	4	3 <sup>11</sup> / <sub>16</sub>
3 x 3	12	3 <sup>9</sup> / <sub>16</sub>	6	4 <sup>11</sup> / <sub>16</sub>
4 x 4	14	4 <sup>5</sup> / <sub>8</sub>	7	5 <sup>7</sup> / <sub>8</sub>

Test Tee and cleanout comes as complete assembly including cap and coupling.

FIG. 8 Test T with Clean-Out

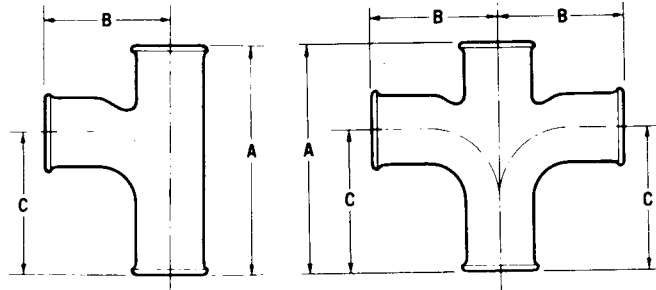

Dimensions<sup>A</sup>, in.

Size	A	B	C
1½ by 1½	6	3½	3¾
2 by 1½	8	3¾	5
2 by 2	8	4½	5
3 by 1½	12	4¼	7 <sup>7</sup> / <sub>16</sub>
3 by 2	12	5	7 <sup>7</sup> / <sub>16</sub>
3 by 3	12	6 <sup>3</sup> / <sub>8</sub>	7 <sup>7</sup> / <sub>16</sub>
4 by 1½	14	4 <sup>7</sup> / <sub>8</sub>	8¾
4 by 2	14	5¾	8¾
4 by 3	14	7	8¾
4 by 4	14	8¼	8¾
6 by 2	20	6¾	12 <sup>3</sup> / <sub>8</sub>
6 by 3	20	8	12 <sup>3</sup> / <sub>8</sub>
6 by 4	20	9 <sup>5</sup> / <sub>16</sub>	12 <sup>3</sup> / <sub>8</sub>
6 by 6	20	12	12 <sup>3</sup> / <sub>8</sub>

<sup>A</sup>Dimensions to beaded flanges include coupling allowance.

FIG. 9 Sanitary T

Size	A	B	C	D
1½ x 1½ x 2	6	3 <sup>7</sup> / <sub>8</sub>	2 <sup>1</sup> / <sub>8</sub>	7

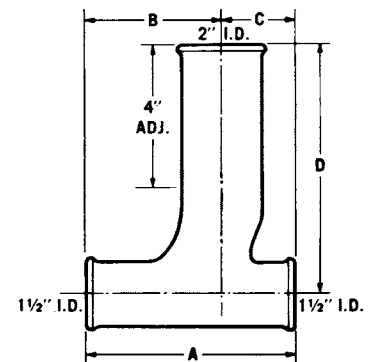

FIG. 10 Adjustable Sanitary T

Size	A	B	C
1½ x 1½ x 1½	8¾	3½	3½

\*Can be field cut.

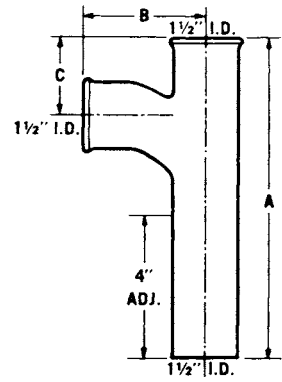

FIG. 11 Adjustable Sanitary T (Plain End Outlet)

Size	A	B	C
1½ x 1½	4½	2⅞	2¼
2 x 1½	4¾	2⅜	2⅜
2 x 2	5⅜	2¾	2¾
3 x 2	9	4⅛	5⅛
3 x 3	9	4⅛	5⅛
4 x 1½	10	4⅝	6⅝
4 x 2	10	4⅞	6⅝
4 x 3	10	5⅜	6⅝
4 x 4	10	6¼	6⅝
6 x 2	16	5⅞	9½
6 x 3	16	6¾	9½
6 x 4	16	7⅞	9½
6 x 6	16	9⅞	9¼

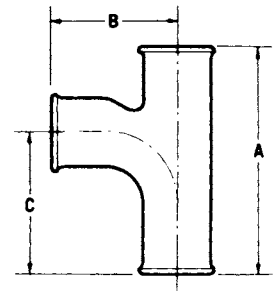
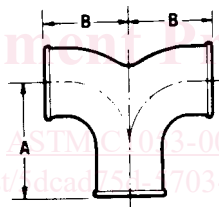

FIG. 12 Compact Single Sanitary T



Dimensions<sup>A</sup>, in.

Size	A	B
1½	3	2⅞
2 by 2 by 1½	3¼	2¼
2	3½	2¼
3	5	4½
4	6½	5¾
6	8½	7

<sup>A</sup>Dimensions to beaded flanges include coupling allowance.

FIG. 13 Double Quarter Bend

Size	A	B
1½	10	2½
**2 x 2 x 1½	10	2¼
2	10	2¼
3		
4		
6		

\*Can be field cut.  
 \*\*Branch is 1½" I.D.

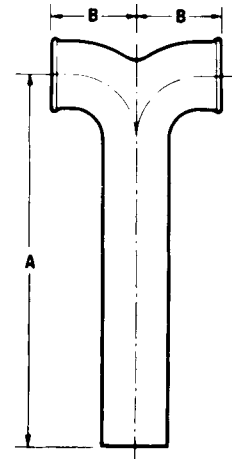
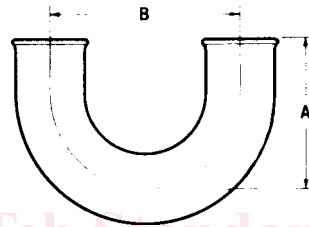

FIG. 14 Double Quarter Bend (Plain End Outlet)



Dimensions<sup>A</sup>, in.

Size	A	B
1½	4	5
2	4½	5½
3	5½	6½
4	6½	7½

<sup>A</sup>Dimensions to beaded flanges include coupling allowance.

FIG. 15 U Bend

ASTM C1053-00

<https://standards.iteh.ai/catalog/standards/sist/5dcad75d-5703-45a6-9e42-13201da46276/astm-c1053-00>



Dimensions<sup>A</sup>, in.

Size	A
1½	1
2	1
3	1½
4	1¼
6	1½

<sup>A</sup>Dimensions to beaded flanges include coupling allowance.

FIG. 16 Cleanout Plug