



SLOVENSKI STANDARD

SIST EN 4116:2005

01-junij-2005

BUXca Yý U
SIST EN 4116:2004

Aerospace series - Nuts, hexagonal, self-locking, in heat resisting steel FE-PA2601 (A286), silver plated on thread - Classification: 1 100 MPa (at ambient temperature) / 425 °C

Aerospace series - Nuts, hexagonal, self-locking, in heat resisting steel FE-PA2601 (A286), silver plated on thread - Classification: 1 100 MPa (at ambient temperature) / 425 °C

(standards.iteh.ai)

Luft- und Raumfahrt - Sechskantmuttern, selbstsichernd, aus hochwarmfestem Stahl FE-PA2601 (A286), Gewinde versilbert - Klasse: 1 100 MPa (bei Raumtemperatur) / 425 °C

Série aérospatiale - Écrous hexagonaux, a freinage interne, en acier résistant a chaud FE-PA2601 (A286), argentés sur filetage - Classification : 1 100 MPa (a température ambiante) / 425 °C

Ta slovenski standard je istoveten z: EN 4116:2004

ICS:

49.030.30 Matice Nuts

SIST EN 4116:2005 en

iTeh STANDARD PREVIEW
(standards.iteh.ai)

SIST EN 4116:2005

<https://standards.iteh.ai/catalog/standards/sist/9e50a57b-a99e-47b5-928c-f63a72dd2f2b/sist-en-4116-2005>

English version

**Aerospace series - Nuts, hexagonal, self-locking, in heat
resisting steel FE-PA2601 (A286), silver plated on thread -
Classification: 1 100 MPa (at ambient temperature) / 425° C**

Série aérospatiale - Écrous hexagonaux, à freinage interne,
en acier résistant à chaud FE-PA2601 (A286), argentés sur
filetage - Classification : 1 100 MPa (à température
ambiante) / 425° C

Luft- und Raumfahrt - Sechskantmuttern, selbstsichernd,
aus hochwarmfestem Stahl FE-PA2601 (A286), Gewinde
versilbert - Klasse: 1 100 MPa (bei Raumtemperatur) / 425°
C

This European Standard was approved by CEN on 11 September 2003.

CEN members are bound to comply with the CEN/CENELEC Internal Regulations which stipulate the conditions for giving this European Standard the status of a national standard without any alteration. Up-to-date lists and bibliographical references concerning such national standards may be obtained on application to the Central Secretariat or to any CEN member.

This European Standard exists in three official versions (English, French, German). A version in any other language made by translation under the responsibility of a CEN member into its own language and notified to the Central Secretariat has the same status as the official versions.

CEN members are the national standards bodies of Austria, Belgium, Cyprus, Czech Republic, Denmark, Estonia, Finland, France, Germany, Greece, Hungary, Iceland, Ireland, Italy, Latvia, Lithuania, Luxembourg, Malta, Netherlands, Norway, Poland, Portugal, Slovakia, Slovenia, Spain, Sweden, Switzerland and United Kingdom.



EUROPEAN COMMITTEE FOR STANDARDIZATION
COMITÉ EUROPÉEN DE NORMALISATION
EUROPÄISCHES KOMITEE FÜR NORMUNG

Management Centre: rue de Stassart, 36 B-1050 Brussels

Contents	Page
Foreword.....	3
1 Scope	4
2 Normative references	4
3 Required characteristics	4
4 Designation	6
5 Marking	6
6 Technical specification	6

iTeh STANDARD PREVIEW
(standards.iteh.ai)

[SIST EN 4116:2005](https://standards.iteh.ai/catalog/standards/sist/9e50a57b-a99e-47b5-928c-f63a72dd2f2b/sist-en-4116-2005)

<https://standards.iteh.ai/catalog/standards/sist/9e50a57b-a99e-47b5-928c-f63a72dd2f2b/sist-en-4116-2005>

Foreword

This document (EN 4116:2004) has been prepared by the European Association of Aerospace Manufacturers - Standardization (AECMA-STAN).

After enquiries and votes carried out in accordance with the rules of this Association, this Standard has received the approval of the National Associations and the Official Services of the member countries of AECMA, prior to its presentation to CEN.

This European Standard shall be given the status of a national standard, either by publication of an identical text or by endorsement, at the latest by May 2005, and conflicting national standards shall be withdrawn at the latest by May 2005.

This document supersedes EN 4116:2003.

According to the CEN/CENELEC Internal Regulations, the national standards organizations of the following countries are bound to implement this European Standard: Austria, Belgium, Cyprus, Czech Republic, Denmark, Estonia, Finland, France, Germany, Greece, Hungary, Iceland, Ireland, Italy, Latvia, Lithuania, Luxembourg, Malta, Netherlands, Norway, Poland, Portugal, Slovakia, Slovenia, Spain, Sweden, Switzerland and the United Kingdom.

iTeh STANDARD PREVIEW
(standards.iteh.ai)

[SIST EN 4116:2005](https://standards.iteh.ai/catalog/standards/sist/9e50a57b-a99e-47b5-928c-f63a72dd2f2b/sist-en-4116-2005)

<https://standards.iteh.ai/catalog/standards/sist/9e50a57b-a99e-47b5-928c-f63a72dd2f2b/sist-en-4116-2005>

EN 4116:2004 (E)

1 Scope

This standard specifies the characteristics of self-locking hexagonal nuts in FE-PA2601, silver plated on thread, for aerospace applications.

Classification: 1 100 MPa ¹⁾ / 425 °C ²⁾

2 Normative references

The following referenced documents are indispensable for the application of this document. For dated references, only the edition cited applies. For undated references, the latest edition of the referenced document (including any amendments) applies.

ISO 5855-2, *Aerospace – MJ threads – Part 2: Limit dimensions for bolts and nuts*

ISO 7995, *Aerospace – Nuts, hexagon, self-locking, with MJ threads, classifications: 1 100 MPa (at ambient temperature) / 235 °C, 1 100 MPa (at ambient temperature) / 315 °C, 1 100 MPa (at ambient temperature) / 425 °C – Dimensions*

EN 2399, *Heat resisting steel FE-PA92-HT – $R_m \geq 900$ MPa – Bar for forged bolts $D \leq 25$ mm – Aerospace series ³⁾*

EN 2424, *Aerospace series – Marking of aerospace products*

EN 2786, *Aerospace series – Electrolytic silver plating of fasteners ⁴⁾*

EN 3152, *Aerospace series – Nuts, self-locking, MJ threads, in heat resisting steel FE-PA2601 (A286), silver plated or uncoated – Classification: 1 100 MPa (at ambient temperature) / 425 °C – Technical specification*

EN 3638, *Aerospace series – Heat resisting alloy FE-PA2601 (X6NiCrTiMoV26-15) – Consumable electrode remelted – Solution and precipitation treated – Sheet, strip and plate – $0,5 \text{ mm} \leq a \leq 10 \text{ mm}$ ⁴⁾*

EN 3639, *Aerospace series – Heat resisting alloy FE-PA2601 – Softened and cold worked – Wire for forged fasteners – $D \leq 15 \text{ mm}$ – $900 \text{ MPa} \leq R_m \leq 1 100 \text{ MPa}$ ⁴⁾*

3 Required characteristics

3.1 Configuration – Dimensions – Tolerances – Masses

See Figure 1 and Table 1.

Dimensions and tolerances are in millimetres and are in accordance with ISO 7995. They apply after silver plating for thread surface.

3.2 Materials

EN 2399, EN 3638 or EN 3639

3.3 Surface treatment

EN 2786 on thread and chamfers

Thickness:

- thread \geq MJ6: 5 μm min. on thread flanks;
- thread \leq MJ5: shall show complete coverage, without thickness requirement;
- chamfers: shall show complete coverage, without thickness requirement.

1) Correspond to the minimum tensile stress which the nut is able to withstand at ambient temperature without breaking or cracking when tested with a bolt of a higher strength class.

2) Maximum test temperature of the parts

3) Published as AECMA Standard at the date of publication of this standard

4) Published as AECMA Prestandard at the date of publication of this standard

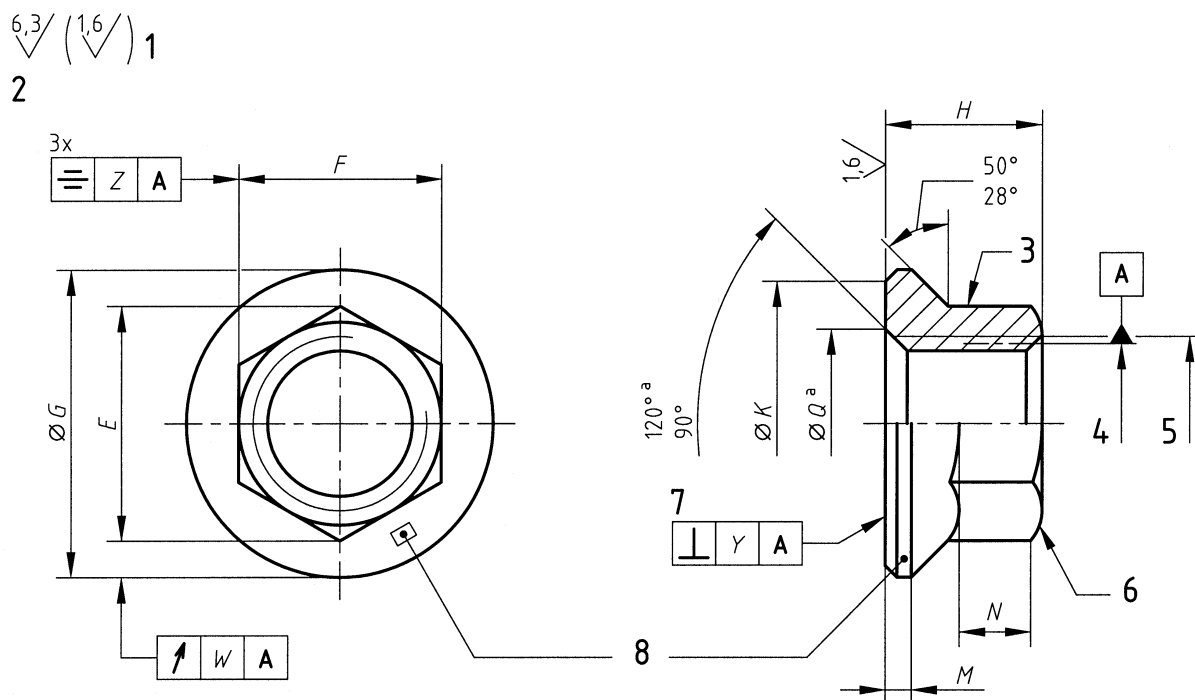
**Key**

- 1 values applicable before silver plating. Thread surface will be as achieved by normal methods of manufacture
- 2 remove sharp edges 0,1 to 0,4.
- 3 form out-of-round in this area to achieve the self-locking requirement (tooling marks permissible).
- 4 pitch diameter
- 5 thread
- 6 chamfer, radius or broken edge
- 7 not convex
- 8 marking

Details of form not stated are left to the manufacturer's discretion.

^a All forms of entry (radius or chamfer) are permissible within these limiting dimensions.

Figure 1**Table 1**

Code	Thread ^a Designation	E		F ^b		G	H	K	M	N ^c		Q		W	Y	Z ^d	Mass kg/1 000 parts ≈
		min.	nom.	Tol.	max.	max.	min.	min.	min.	max.	min.						
030	MJ3×0,5-4H6H	4,2	4	h12	6	3	5,3	0,4	1,2	3,8	3,2	0,2				0,2	0,28
040	MJ4×0,7-4H6H	5,3	5		7,4	4	6,7	0,5	1,5	4,8	4,2						0,50
050	MJ5×0,8-4H6H	6,5	6		9,1	5	8,3	0,6	2	5,8	5,2						0,80
060	MJ6×1-4H5H	7,6	7		10,6	5,4	9,8	0,7	2,3	7,1	6,3						1,15
070	MJ7×1-4H5H	8,7	8		12,1	6,3	11,3	0,8	2,7	8,1	7,3						1,70
080	MJ8×1-4H5H	10,9	10	h13	13,6	7,2	12,8	0,9	3,2	9,1	8,3	0,3	0,13		0,4	3,15	
100	MJ10×1,25-4H5H	13,2	12		16,8	9	15,8	1,1	3,8	11,1	10,3					4,75	
120	MJ12×1,25-4H5H	15,5	14		19,9	10,8	18,8	1,4	4,5	13,1	12,3					10	

^a In accordance with ISO 5855-2. In the self-locking zone, the tolerances apply before forming out-of-round.

^b Applicable before forming out-of-round, but finished nuts shall fit a standard socket wrench.

^c Wrench pad engagement

^d Values apply before forming out-of-round.

EN 4116:2004 (E)

4 Designation

EXAMPLE

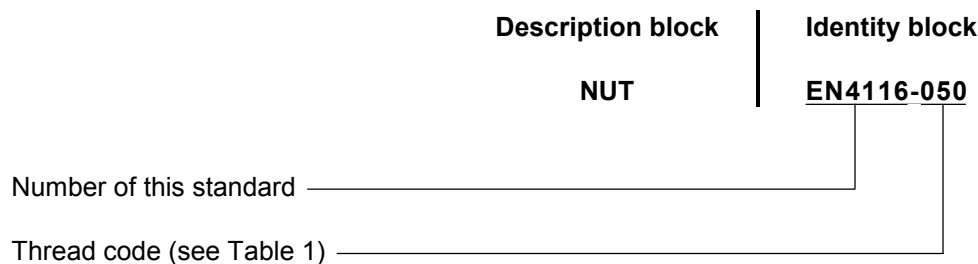

NOTE If necessary, the code I9005 shall be placed between the description block and the identity block.

5 Marking

EN 2424, as indicated on Figure 1 and Table 2.

Table 2

Thread code	Style
030 and 040	N
050 to 120	C

<https://standards.iteh.ai/catalog/standards/sist/9e50a57b-a99e-47b5-928c-f63a72dd2f2b/sist-en-4116-2005>

6 Technical specification

EN 3152