



SLOVENSKI STANDARD

SIST EN 4121:2005

01-junij-2005

BUXca Yý U
SIST EN 4121:2004

Aerospace series - Shank nuts, serrated, self-locking, in heat resisting steel FE-PA2601 (A286), silver plated on thread - Classification: 1 100 MPa (at ambient temperature) / 650 °C

Aerospace series - Shank nuts, serrated, self-locking, in heat resisting steel FE-PA2601 (A286), silver plated on thread - Classification: 1 100 MPa (at ambient temperature) / 650 °C

(standards.iteh.ai)

Luft- und Raumfahrt - Einnietmuttern, verzahnt, selbstsichernd, aus hochwarmfestem Stahl FE-PA2601 (A286), Gewinde versilbert - Klasse: 1 100 MPa (bei Raumtemperatur) / 650 °C

Série aérospatiale - Écrous dentelés a sertir, a freinage interne, en acier résistant a chaud FE-PA2601 (A286), argentés sur filetage - Classification : 1 100 MPa (a température ambiante) / 650 °C

Ta slovenski standard je istoveten z: EN 4121:2004

ICS:

49.030.30 Matice Nuts

SIST EN 4121:2005 en

iTeh STANDARD PREVIEW
(standards.iteh.ai)

SIST EN 4121:2005

<https://standards.iteh.ai/catalog/standards/sist/214f84f8-9c51-4ece-97d5-7992adda6161/sist-en-4121-2005>

EUROPEAN STANDARD
NORME EUROPÉENNE
EUROPÄISCHE NORM

EN 4121

November 2004

ICS 49.030.30

Supersedes EN 4121:2003

English version

**Aerospace series - Shank nuts, serrated, self-locking, in heat
resisting steel FE-PA2601 (A286), silver plated on thread -
Classification: 1 100 MPa (at ambient temperature) / 650° C**

Série aérospatiale - Écrous dentelés à sertir, à freinage
interne, en acier résistant à chaud FE-PA2601 (A286),
argentés sur filetage - Classification : 1 100 MPa (à
température ambiante) / 650° C

Luft- und Raumfahrt - Einnietmuttern, verzahnt,
selbstsichernd, aus hochwarmfestem Stahl FE-PA2601
(A286), Gewinde versilbert - Klasse: 1 100 MPa (bei
Raumtemperatur) / 650° C

This European Standard was approved by CEN on 11 September 2003.

CEN members are bound to comply with the CEN/CENELEC Internal Regulations which stipulate the conditions for giving this European Standard the status of a national standard without any alteration. Up-to-date lists and bibliographical references concerning such national standards may be obtained on application to the Central Secretariat or to any CEN member.

This European Standard exists in three official versions (English, French, German). A version in any other language made by translation under the responsibility of a CEN member into its own language and notified to the Central Secretariat has the same status as the official versions.

CEN members are the national standards bodies of Austria, Belgium, Cyprus, Czech Republic, Denmark, Estonia, Finland, France, Germany, Greece, Hungary, Iceland, Ireland, Italy, Latvia, Lithuania, Luxembourg, Malta, Netherlands, Norway, Poland, Portugal, Slovakia, Slovenia, Spain, Sweden, Switzerland and United Kingdom.



EUROPEAN COMMITTEE FOR STANDARDIZATION
COMITÉ EUROPÉEN DE NORMALISATION
EUROPÄISCHES KOMITEE FÜR NORMUNG

Management Centre: rue de Stassart, 36 B-1050 Brussels

Contents	Page
Foreword.....	3
1 Scope	4
2 Normative references	4
3 Required characteristics.....	4
3.1 Configuration – Dimensions – Tolerances – Masses	4
3.2 Materials	4
3.3 Surface treatment	5
4 Designation	6
5 Marking	6
6 Technical specification	6
7 Installation	6

iTeh STANDARD PREVIEW
(standards.iteh.ai)

[SIST EN 4121:2005](https://standards.iteh.ai/catalog/standards/sist/214f84f8-9c51-4ece-97d5-7992adda6161/sist-en-4121-2005)

<https://standards.iteh.ai/catalog/standards/sist/214f84f8-9c51-4ece-97d5-7992adda6161/sist-en-4121-2005>

Foreword

This document (EN 4121:2004) has been prepared by the European Association of Aerospace Manufacturers - Standardization (AECMA-STAN).

After enquiries and votes carried out in accordance with the rules of this Association, this Standard has received the approval of the National Associations and the Official Services of the member countries of AECMA, prior to its presentation to CEN.

This European Standard shall be given the status of a national standard, either by publication of an identical text or by endorsement, at the latest by May 2005, and conflicting national standards shall be withdrawn at the latest by May 2005.

This document supersedes EN 4121:2003.

According to the CEN/CENELEC Internal Regulations, the national standards organizations of the following countries are bound to implement this European Standard: Austria, Belgium, Czech Republic, Denmark, Finland, France, Germany, Greece, Iceland, Ireland, Italy, Luxembourg, Malta, Netherlands, Norway, Portugal, Spain, Sweden, Switzerland and the United Kingdom.

iTeh STANDARD PREVIEW
(standards.iteh.ai)

[SIST EN 4121:2005](https://standards.iteh.ai/catalog/standards/sist/214f84f8-9c51-4ece-97d5-7992adda6161/sist-en-4121-2005)

<https://standards.iteh.ai/catalog/standards/sist/214f84f8-9c51-4ece-97d5-7992adda6161/sist-en-4121-2005>

EN 4121:2004 (E)**1 Scope**

This standard specifies the characteristics of self-locking serrated shank nuts in FE-PA2601, silver plated on thread, for aerospace applications.

Classification: 1 100 MPa ¹⁾ / 650 °C ²⁾

2 Normative references

The following referenced documents are indispensable for the application of this document. For dated references, only the edition cited applies. For undated references, the latest edition of the referenced document (including any amendments) applies.

ISO 5855-2, *Aerospace – MJ threads – Part 2: Limit dimensions for bolts and nuts*

EN 2399, *Heat resisting steel FE-PA92-HT – $R_m \geq 900$ MPa – Bar for forged bolts $D \leq 25$ mm – Aerospace series* ³⁾

EN 2424, *Aerospace series – Marking of aerospace products*

EN 2786, *Aerospace series – Electrolytic silver plating of fasteners* ⁴⁾

EN 3004, *Aerospace series – Nuts, self-locking, MJ threads, in heat resisting steel FE-PA2601 (A286) – Classification: 1 100 MPa (at ambient temperature) / 650 °C – Technical specification*

EN 3064, *Aerospace series – Shank nuts, self-locking, serrated – Installation procedure*

EN 3065, *Aerospace series – Installation holes for self-locking, serrated shank nuts – Design standard*

EN 3639, *Aerospace series – Heat resisting alloy FE-PA2601 – Softened and cold worked – Wire for forged fasteners – $D \leq 15$ mm – 900 MPa $\leq R_m \leq 1$ 100 MPa* ⁴⁾

3 Required characteristics**3.1 Configuration – Dimensions – Tolerances – Masses**

See Figure 1 and Table 1.

Dimensions and tolerances are in millimetres. They apply after silver plating for thread surface.

3.2 Materials

EN 2399 or EN 3639

1) Correspond to the minimum tensile stress which the nut is able to withstand at ambient temperature without breaking or cracking when tested with a bolt of a higher strength class.

2) Maximum test temperature of the parts

3) Published as AECMA Standard at the date of publication of this standard

4) Published as AECMA Prestandard at the date of publication of this standard

3.3 Surface treatment

EN 2786 on thread only

Thickness:

- thread \geq MJ6: 5 μm min. on thread flanks;
- thread MJ5: shall show complete coverage, without thickness requirement.

Coating may extend to counterbore and chamfers at manufacturer's option, without thickness requirement.

$$\sqrt[3,2]{\left(\sqrt[1,6]{}\right)^1}$$

2

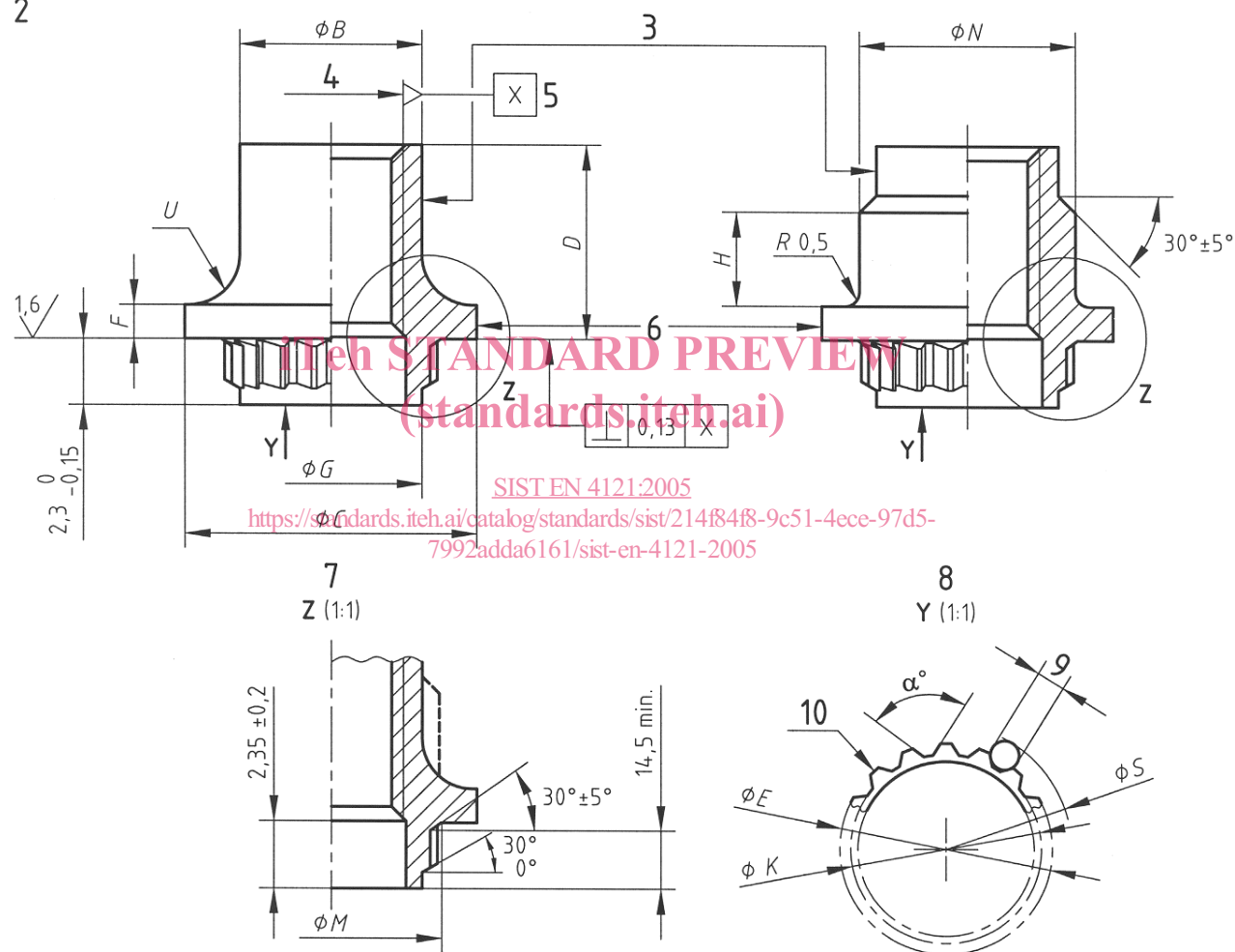

Key

- | | | | |
|---|---|----|---------------------|
| 1 | values applicable before silver plating. Thread surface will be as achieved by normal methods of manufacture. | 5 | pitch diameter |
| 2 | remove sharp edges 0,1 to 0,4. | 6 | marking |
| 3 | form out-of-round in this area to achieve the self-locking requirement (tooling marks permissible). | 7 | style 1 |
| 4 | thread | 8 | style 2 |
| | | 9 | diameter P (wire) |
| | | 10 | number of teeth J |

NOTE Configurations, style 1 or style 2, are permitted.

Figure 1

Table 1

Thread ^a		<i>B</i> ^b	<i>C</i>		<i>D</i>		<i>E</i>		<i>F</i>	<i>G</i>	<i>H</i>	<i>J</i>	No of teeth
Code	Designation		max.	min.	max.	min.	max.	min.					
050	MJ5×0,8-4H6H	6,3	10,1	9,8	6,8	6,1	7,38	7,15	0,9	5,12	3,3	17	
060	MJ6×1-4H5H	7,7	11,5	11,2	8,6	7,9	8,98	8,75	1,4	6,56	3,6	20	
070	MJ7×1-4H5H	8,4	12,7	12,4	9,7	9	10,28	10,05		8,10	5	23	
080	MJ8×1-4H5H	9,5			10	9,3				7			

continued

Code	<i>K</i>		<i>M</i>	<i>N</i>	Wire		<i>S</i>		<i>U</i>		$\alpha^\circ \pm 1^\circ$	Mass ^c	
	max.	min.			No	<i>P</i>	max.	min.	max.	min.		Style 1	Style 2
050	6,62	6,36	7,7	7,7	3	1,0	8,730	8,639	2,4	1,6	86°30'	1,71	1,97
060	8,17	7,91	9,1	8,7	2	1,2	10,638	10,547			102°	2,73	3,02
070	9,44	9,18	10,4	9,8	3	1,5	12,536	12,445	2,9	2,1	102°	3,46	3,84
080				10,9							102°	3,58	4,21

^a In accordance with ISO 5855-2. In the self-locking zone, the tolerances apply before forming out-of-round.

^b Applicable before forming out-of-round

^c Mass ≈ quoted in kg/1 000 parts

4 Designation

SIST EN 4121:2005
<https://standards.iteh.ai/catalog/standards/sist/214f84f8-9c51-4ece-97d5-7992adda6161/sist-en-4121-2005>

EXAMPLE

Description block	Identity block
NUT	EN4121-080
Number of this standard _____	
Thread code (see Table 1) _____	

NOTE If necessary, the code I9005 shall be placed between the description block and the identity block.

5 Marking

EN 2424, style A, as indicated on Figure 1.

6 Technical specification

EN 3004

7 Installation

The nuts shall be installed according to the procedure specified in EN 3064 in installation holes to EN 3065. Careful attention shall be paid to notch sensitivity of the materials in which they are to be installed.