

---

---

**Acoustics — Determination of sound  
absorption coefficient and impedance  
in impedance tubes —**

**Part 2:  
Transfer-function method**

iTeh STANDARD PREVIEW

*Acoustique — Détermination du facteur d'absorption acoustique  
et de l'impédance des tubes d'impédance —*

*Partie 2: Méthode de la fonction de transfert*  
[ISO 10534-2:1998](#)

<https://standards.iteh.ai/catalog/standards/sist/161fd78b-ceaf-4967-8ca1-5a1db6ad53b9/iso-10534-2-1998>



## Contents

Page

1	Scope .....	1
2	Definitions and symbols .....	1
3	Principle.....	3
4	Test equipment .....	3
5	Preliminary test and measurements .....	7
6	Test specimen mounting .....	8
7	Test procedure .....	9
8	Precision.....	13
9	Test report .....	14

### Annexes

A	Preliminary measurements .....	15
B	Procedure for the one-microphone technique .....	20
C	Pressure-release termination of test sample .....	21
D	Theoretical background .....	22
E	Error sources .....	24
F	Determination of diffuse sound absorption coefficient $\alpha_{st}$ of locally reacting absorbers from the results of this part of ISO 10534 .....	26
G	Bibliography .....	27

© ISO 1998

All rights reserved. Unless otherwise specified, no part of this publication may be reproduced or utilized in any form or by any means, electronic or mechanical, including photocopying and microfilm, without permission in writing from the publisher.

International Organization for Standardization  
Case postale 56 • CH-1211 Genève 20 • Switzerland  
Internet iso@iso.ch

Printed in Switzerland

## Foreword

ISO (the International Organization for Standardization) is a worldwide federation of national standards bodies (ISO member bodies). The work of preparing International Standards is normally carried out through ISO technical committees. Each member body interested in a subject for which a technical committee has been established has the right to be represented on that committee. International organizations, governmental and non-governmental, in liaison with ISO, also take part in the work. ISO collaborates closely with the International Electrotechnical Commission (IEC) on all matters of electrotechnical standardization.

Draft International Standards adopted by the technical committees are circulated to the member bodies for voting. Publication as an International Standard requires approval by at least 75 % of the member bodies casting a vote.

iTeh STANDARD PREVIEW  
(standards.iteh.ai)

International Standard ISO 10534-2 was prepared by Technical Committee ISO/TC 43, *Acoustics*, Subcommittee SC 2, *Building acoustics*.

ISO 10534 consists of the following parts, under the general title *Acoustics — Determination of sound absorption coefficient and impedance in impedance tubes*:  
<https://standards.iteh.ai/en/standards/list/161fd78b-ceaf-4967-8ca1-5a1db6ad53b9/iso-10534-2-1998>

— *Part 1: Method using standing wave ratio*

— *Part 2: Transfer-function method*

Annexes A to C form an integral part of this part of ISO 10534. Annexes D to G are for information only.

**iTeh STANDARD PREVIEW**  
**(standards.iteh.ai)**

ISO 10534-2:1998

<https://standards.iteh.ai/catalog/standards/sist/161fd78b-ceaf-4967-8ca1-5a1db6ad53b9/iso-10534-2-1998>

## 1 Scope

This test method covers the use of an impedance tube, two microphone locations and a digital frequency analysis system for the determination of the sound absorption coefficient of sound absorbers for normal sound incidence. It can also be applied for the determination of the acoustical surface impedance or surface admittance of sound absorbing materials. Since the impedance ratios of a sound absorptive material are related to its physical properties, such as airflow resistance, porosity, elasticity and density, measurements described in this test method are useful in basic research and product development.

The test method is similar to the test method specified in ISO 10534-1 in that it uses an impedance tube with a sound source connected to one end and the test sample mounted in the tube at the other end. However, the measurement technique is different. In this test method, plane waves are generated in a tube by a noise source, and the decomposition of the interference field is achieved by the measurement of acoustic pressures at two fixed locations using wall-mounted microphones or an in-tube traversing microphone, and subsequent calculation of the complex acoustic transfer function, the normal incidence absorption and the impedance ratios of the acoustic material. The test method is intended to provide an alternative, and generally much faster, measurement technique than that of ISO 10534-1.

Compared with the measurement of the sound absorption in a reverberation room according to the method specified in ISO 354, there are some characteristic differences. The reverberation room method will (under ideal conditions) determine the sound absorption coefficient for diffuse sound incidence, and the method can be used for testing of materials with pronounced structures in the lateral and normal directions. However, the reverberation room method requires test specimens which are rather large, so it is not convenient for research and development work, where only small samples of the absorber are available. The impedance tube method is limited to parametric studies at normal incidence but requires samples of the test object which are of the same size as the cross-section of the impedance tube. For materials that are locally reacting, diffuse incidence sound absorption coefficients can be estimated from measurement results obtained by the impedance tube method. For transformation of the test results from the impedance tube method (normal incidence) to diffuse sound incidence, see annex F.

## 2 Definitions and symbols

For the purposes of this part of ISO 10534 the following definitions apply.

### 2.1

#### sound absorption coefficient at normal incidence

$\alpha$   
ratio of sound power entering the surface of the test object (without return) to the incident sound power for a plane wave at normal incidence

## 2.2 sound pressure reflection factor at normal incidence

$r$   
complex ratio of the amplitude of the reflected wave to that of the incident wave in the reference plane for a plane wave at normal incidence

## 2.3 reference plane

cross-section of the impedance tube for which the reflection factor  $r$  or the impedance  $Z$  or the admittance  $G$  are determined and which is usually the surface of the test object, if flat

NOTE The reference plane is assumed to be at  $x = 0$ .

## 2.4 normal surface impedance

$Z$   
ratio of the complex sound pressure  $p(0)$  to the normal component of the complex sound particle velocity  $v(0)$  at an individual frequency in the reference plane

## 2.5 normal surface admittance

$G$   
inverse of the normal surface impedance  $Z$

## 2.6 wave number

$k_0$   
variable defined by

$$k_0 = \omega/c_0 = 2\pi f/c_0$$

where

$\omega$  is the angular frequency;

$f$  is the frequency;

$c_0$  is the speed of sound.

NOTE In general the wave number is complex, so

$$k_0 = k_0' - jk_0''$$

where

$k_0'$  is the real component ( $k_0' = 2\pi/\lambda_0$ );

$\lambda_0$  is the wavelength;

$k_0''$  is the imaginary component which is the attenuation constant, in nepers per metre.

## 2.7 complex sound pressure

$p$   
Fourier Transform of the temporal acoustic pressure

## 2.8 cross spectrum

$S_{12}$   
product  $p_2 p_1^*$ , determined from the complex sound pressures  $p_1$  and  $p_2$  at two microphone positions

NOTE \* means the complex conjugate.

**iTeh STANDARD PREVIEW**  
**(standards.iteh.ai)**

[ISO 10534-2:1998](https://standards.iteh.ai/catalog/standards/sist/161fd78b-ceaf-4967-8ca1-5a1db6ad53b9/iso-10534-2-1998)

<https://standards.iteh.ai/catalog/standards/sist/161fd78b-ceaf-4967-8ca1-5a1db6ad53b9/iso-10534-2-1998>

## 2.9 auto spectrum

$S_{11}$   
product  $p_1 \cdot p_1^*$ , determined from the complex sound pressure  $p_1$  at microphone position one

NOTE \* means the complex conjugate.

## 2.10 transfer function

$H_{12}$   
transfer function from microphone position one to two, defined by the complex ratio  $p_2/p_1 = S_{12}/S_{11}$  or  $S_{22}/S_{21}$ , or  $[(S_{12}/S_{11})(S_{22}/S_{21})]^{1/2}$

## 2.11 calibration factor

$H_c$   
factor used to correct for amplitude and phase mismatches between the microphones

NOTE See 7.5.2.

# 3 Principle

The test sample is mounted at one end of a straight, rigid, smooth and airtight impedance tube. Plane waves are generated in the tube by a sound source (random, pseudo-random sequence, or chirp), and the sound pressures are measured at two locations near to the sample. The complex acoustic transfer function of the two microphone signals is determined and used to compute the normal-incidence complex reflection factor (see annex C), the normal-incidence absorption coefficient, and the impedance ratio of the test material.

The quantities are determined as functions of the frequency with a frequency resolution which is determined from the sampling frequency and the record length of the digital frequency analysis system used for the measurements. The usable frequency range depends on the width of the tube and the spacing between the microphone positions. An extended frequency range may be obtained from the combination of measurements with different widths and spacings.

The measurements may be performed by employing one of two techniques:

- 1: two-microphone method (using two microphones in fixed locations);
- 2: one-microphone method (using one microphone successively in two locations).

Technique 1 requires a pre-test or in-test correction procedure to minimize the amplitude and phase difference characteristics between the microphones; however, it combines speed, high accuracy, and ease of implementation. Technique 1 is recommended for general test purposes.

Technique 2 has particular signal generation and processing requirements and may require more time; however, it eliminates phase mismatch between microphones and allows the selection of optimal microphone locations for any frequency. Technique 2 is recommended for the assessment of tuned resonators and/or precision, and its requirements are described in more detail in annex B.

# 4 Test equipment

## 4.1 Construction of the impedance tube

The apparatus is essentially a tube with a test sample holder at one end and a sound source at the other. Microphone ports are usually located at two or three locations along the wall of the tube, but variations involving a centre mounted microphone or probe microphone are possible.

The impedance tube shall be straight with a uniform cross-section (diameter or cross dimension within  $\pm 0,2\%$ ) and with rigid, smooth, non-porous walls without holes or slits (except for the microphone positions) in the test section. The walls shall be heavy and thick enough so that they are not excited to vibrations by the sound signal and show no vibration resonances in the working frequency range of the tube. For metal walls, a thickness of about 5 % of the diameter is recommended for circular tubes. For rectangular tubes the corners shall be made rigid enough to prevent distortion of the side wall plates. It is recommended that the side wall thickness be about 10 % of the cross dimension of the tube. Tube walls made of concrete shall be sealed by a smooth adhesive finish to ensure air tightness. The same holds for tube walls made of wood; these should be reinforced and damped by an external coating of steel or lead sheets.

The shape of the cross-section of the tube is arbitrary, in principle. Circular or rectangular (if rectangular, then preferably square) cross-sections are recommended.

If rectangular tubes are composed of plates, care shall be taken that there are no air leaks (e.g. by sealing with adhesives or with a finish). Tubes should be sound and vibration isolated against external noise or vibration.

## 4.2 Working frequency range

The working frequency range is

$$f_l < f < f_u \quad (1)$$

where

$f_l$  is the lower working frequency of the tube;

$f$  is the operating frequency;

$f_u$  is the upper working frequency of the tube.

$f_l$  is limited by the accuracy of the signal processing equipment.

$f_u$  is chosen to avoid the occurrence of non-plane wave mode propagation.

The condition for  $f_u$  is:

$$d < 0,58 \lambda_u; \quad f_u \cdot d < 0,58 c_0 \quad (2)$$

for circular tubes with the inside diameter  $d$  in metres and  $f_u$  in hertz.

$$d < 0,5 \lambda_u; \quad f_u \cdot d < 0,50 c_0 \quad (3)$$

for rectangular tubes with the maximum side length  $d$  in metres;  $c_0$  is the speed of sound in metres per second given by equation (5).

The spacing  $s$  in metres between the microphones shall be chosen so that

$$f_u \cdot s < 0,45 c_0 \quad (4)$$

The lower frequency limit is dependent on the spacing between the microphones and the accuracy of the analysis system but, as a general guide, the microphone spacing should exceed 5 % of the wavelength corresponding to the lower frequency of interest, provided that the requirements of equation (4) are satisfied. A larger spacing between the microphones enhances the accuracy of the measurements.

## 4.3 Length of the impedance tube

The tube should be long enough to cause plane wave development between the source and the sample. Microphone measurement points shall be in the plane wave field.



The loudspeaker generally will produce non-plane modes besides the plane wave. They will die out within a distance of about three tube diameters or three times the maximum lateral dimensions of rectangular tubes for frequencies below the lower cut-off frequency of the first higher mode. Thus it is recommended that microphones be located no closer to the source than suggested above, but in any case no closer than one diameter or one maximum lateral dimension, as appropriate.

Test samples will also cause proximity distortions to the acoustic field and the following recommendation is given for the minimum spacing between microphone and sample, depending upon the sample type:

non-structured:	$\frac{1}{2}$ diameter or $\frac{1}{2}$ maximum lateral dimension
semi-lateral structured:	1 diameter or 1 maximum lateral dimension
strongly asymmetrical:	2 diameters or 2 times the maximum lateral dimension

#### 4.4 Microphones

Microphones of identical type shall be used in each location. When side-wall-mounted microphones are used, the diameter of the microphones shall be small compared to  $c_0/f_u$ . In addition, it is recommended that the microphone diameters be less than 20 % of the spacing between them.

For side-wall mounting, it is recommended to use microphones of the pressure type. For in-tube microphones, it is recommended to use microphones of the free-field type.

#### 4.5 Positions of the microphones

When side-wall-mounted microphones are used, each microphone shall be mounted with the diaphragm flush with the interior surface of the tube. A small recess is often necessary as shown in figure 1; the recess should be kept small and be identical for both microphone mountings. The microphone grid shall be sealed tight to the microphone housing and there shall be a sealing between the microphone and the mounting hole.

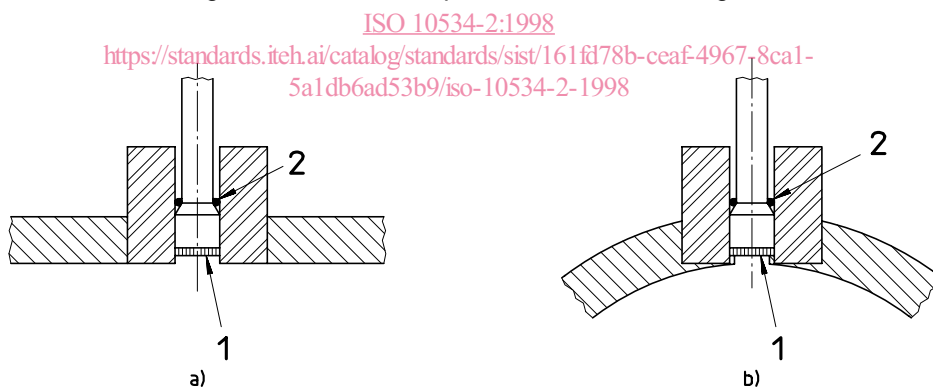

#### Key

- 1 Microphone
- 2 Sealing

**Figure 1 — Examples of typical microphone mounting**

When using a single microphone in two successive wall positions, the microphone position not in use shall be sealed to avoid air leaks and to maintain a smooth surface inside the tube.

When using side-vented microphones, it is important that the pressure equalization vents are not blocked by the microphone mounting. All fixed microphone locations shall be known to an accuracy of  $\pm 0,2$  mm or better, and their spacing  $s$  (see figure 2) shall be recorded. Traversing microphone positions shall be known to an accuracy of  $\pm 0,5$  mm or better.

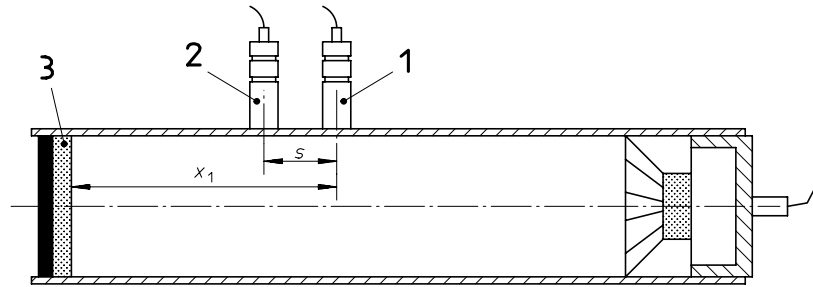

#### Key

- 1 Microphone A
- 2 Microphone B
- 3 Test specimen

Figure 2 — Microphone positions and distances

### 4.6 Acoustic centre of the microphone

For the determination of the acoustic centre of a microphone, or minimizing errors associated with a difference between the acoustic and geometric centres of the microphones, see A.2.3.

### 4.7 Test sample holder

The test sample holder is either integrated into the impedance tube or is a separate unit which is tightly fixed to one end of the tube during the measurement. The length of the sample holder shall be large enough to install test objects with air spaces behind them as required.

If the sample holder is a separate unit, it shall comply in its interior dimensions with the impedance tube to within  $\pm 0,2\%$ . The mounting of the tube shall be tight, without insertion of elastic gaskets (vaseline is recommended for sealing).

For rectangular tubes, it is recommended to integrate the sample holder into the impedance tube and to make the installation section of the tube accessible by a removable cover for mounting the test sample. The contact surfaces of this removable cover with the tube shall be carefully finished and the use of a sealant (vaseline) is recommended in order to avoid small leaks.

For circular tubes, it is recommended to make the test object accessible from both the front and the back end of the sample holder. It is then possible to check the position and flatness of the front surface and the back position.

Generally, in connection with rectangular tubes, it is recommended to install the test object from the side into the tube (instead of pushing it axially into the tube). It is then possible to check the fitting and the position of the test object in the tube, to check the position and the flatness of the front surface, and to reposition the reference plane precisely in relation to the front surface. A sideways insertion also avoids compression of soft materials.

The back plate of the sample holder shall be rigid and shall be fixed tightly to the tube since it serves as a rigid termination in many measurements. A metal plate of thickness not less than 20 mm is recommended.

For some tests a pressure-release termination of the test object by an air volume behind it is needed. This is described in annex C.

### 4.8 Signal processing equipment

The signal processing system shall consist of an amplifier, and a two-channel Fast Fourier Transform (FFT) analysing system. The system is required to measure the sound pressure at two microphone locations and to calculate the transfer function  $H_{12}$  between them. A generator capable of producing the required source signal (see 4.10) compatible with the analysing system is also required.

The dynamic range of the analyser should be greater than 65 dB. The errors in the estimated transfer function  $H_{12}$  due to nonlinearities, resolution, instability and temperature sensitivity of the signal processing equipment shall be less than 0,2 dB.

Using the one-microphone technique, the analysing system shall be able to calculate the transfer function  $H_{12}$  from the generator signal and the two microphone signals measured consecutively.

#### 4.9 Loudspeaker

A membrane loudspeaker (or a pressure chamber loudspeaker for high frequencies with a horn as a transmission element to the impedance tube) should be located at the opposite end of the tube from the test sample holder. The surface of the loudspeaker membrane shall cover at least two-thirds of the cross-sectional area of the impedance tube. The loudspeaker axis may be either coaxial with the tube, or inclined, or connected to the tube by an elbow.

The loudspeaker shall be contained in an insulating box in order to avoid airborne flanking transmission to the microphones. Elastic vibration insulation shall be applied between the impedance tube and the frame of the loudspeaker as well as to the loudspeaker box (preferably between the impedance tube and the transmission element also) in order to avoid structure-borne sound excitation of the impedance tube.

#### 4.10 Signal generator

The signal generator shall be able to generate a stationary signal with a flat spectral density within the frequency range of interest. It may generate one or more of the following: random, pseudo-random, periodic pseudo-random, or chirp excitation, as required.

In the case of the one-microphone technique, a deterministic signal is recommended and a periodic pseudo-random sequence is well suited for this method, although special signal processing will be required. The processing first involves an m-sequence correlation via the fast Hadamard transform to produce an impulse response. The frequency response is subsequently obtained by Fourier transform of the impulse response.

Discrete-frequency generation and display are necessary for tube calibration purposes (see annex A). Discrete-frequency generation and display shall have an uncertainty of less than  $\pm 2\%$ .

#### 4.11 Loudspeaker termination

Resonances of the air column in the impedance tube will always arise. These should be suppressed by lining the inside of the impedance tube near the loudspeaker with at least a 200 mm length of an effective sound-absorbent material.

#### 4.12 Thermometer and barometer

The temperature in the impedance tube shall be measured and kept constant during a measurement with a tolerance of  $\pm 1$  K. The temperature transducer shall be accurate to  $\pm 0,5$  K or better.

The atmospheric pressure shall be measured with a tolerance of  $\pm 0,5$  kPa.

### 5 Preliminary test and measurements

The test equipment shall be assembled, typically as shown in figure 3, and checked before use by a series of tests. These tests help to exclude error sources and secure the minimum requirements. The checks may be considered to be in two categories: prior to or following each test, and periodic calibration tests. In each case the loudspeaker should be operated for at least 10 min prior to a measurement to allow the temperature to stabilize.

Checks prior to and following each test involve microphone response constancy, temperature measurement and a test of the signal-to-noise ratio.

Periodic calibrations are performed with a rigid termination of the empty impedance tube. Their aim is the determination of the acoustic centre of a microphone, and/or the corrections for attenuation in the impedance tube.

These preliminary measurements are described in annex B.

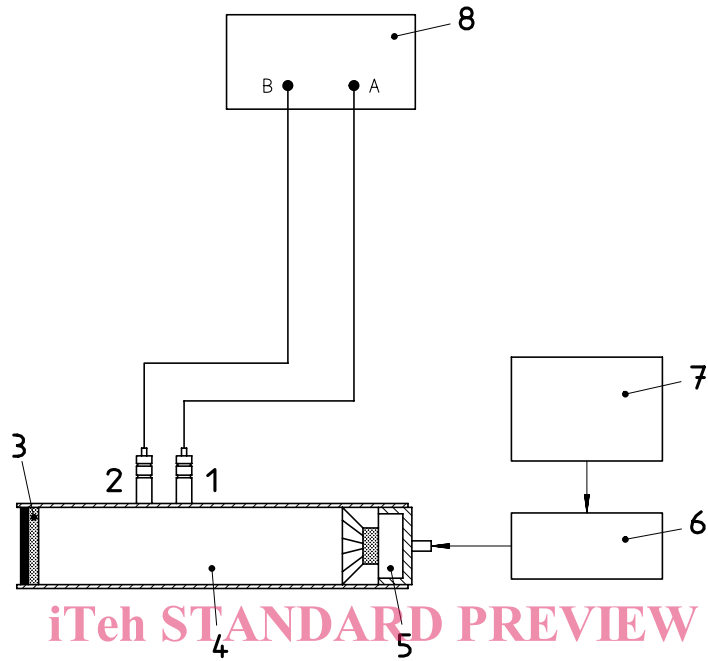

iTeh STANDARD PREVIEW  
(standards.iteh.ai)

- Key**
- |                 |                  |                             |
|-----------------|------------------|-----------------------------|
| 1 Microphone A  | 4 Impedance tube | 7 Signal generator          |
| 2 Microphone B  | 5 Sound source   | 8 Frequency analysis system |
| 3 Test specimen | 6 Amplifier      |                             |

**Figure 3 — Example of layout for test equipment**

## 6 Test specimen mounting