



**SLOVENSKI STANDARD**  
**SIST EN 14957:2007**

**01-marec-2007**

---

**Stroji za obdelavo hrane – Stroji za pomivanje posode s transportnim trakom –  
Varnostne in higienske zahteve**

Food processing machinery - Dishwashing machines with conveyor - Safety and hygiene requirements

Nahrungsmittelmaschinen - Gewerbliche Geschirrspülmaschinen mit  
Transporteinrichtung - Sicherheits- und Hygieneanforderungen

Machines pour les produits alimentaires - Lave-vaisselle à convoyeur - Prescriptions  
relatives à la sécurité et à l'hygiène

[SIST EN 14957:2007](https://standards.iteh.ai/standards/sist/3f53bdba-89bd-4ba4-8909-50c2eca2257e/sist-en-14957-2007)

[https://standards.iteh.ai/catalog/standards/sist/3f53bdba-89bd-4ba4-8909-](https://standards.iteh.ai/catalog/standards/sist/3f53bdba-89bd-4ba4-8909-50c2eca2257e/sist-en-14957-2007)

[50c2eca2257e/sist-en-14957-2007](https://standards.iteh.ai/catalog/standards/sist/3f53bdba-89bd-4ba4-8909-50c2eca2257e/sist-en-14957-2007)

**Ta slovenski standard je istoveten z: EN 14957:2006**

---

**ICS:**

67.260	Tovarne in oprema za živilsko industrijo	Plants and equipment for the food industry
97.040.40	Pomivalni stroji	Dishwashers

**SIST EN 14957:2007**

**en**

**iTeh STANDARD PREVIEW**  
**(standards.iteh.ai)**

SIST EN 14957:2007

<https://standards.iteh.ai/catalog/standards/sist/3f53bdba-89bd-4ba4-8909-50c2eca2257e/sist-en-14957-2007>

ICS 67.260; 97.040.40

English Version

## Food processing machinery - Dishwashing machines with conveyor - Safety and hygiene requirements

Machines pour les produits alimentaires - Lave-vaisselle à convoyeur - Prescriptions relatives à la sécurité et à l'hygiène

Nahrungsmittelmaschinen - Geschirrspülmaschinen mit Transporteinrichtung - Sicherheits- und Hygieneanforderungen

This European Standard was approved by CEN on 22 September 2006.

CEN members are bound to comply with the CEN/CENELEC Internal Regulations which stipulate the conditions for giving this European Standard the status of a national standard without any alteration. Up-to-date lists and bibliographical references concerning such national standards may be obtained on application to the Central Secretariat or to any CEN member.

This European Standard exists in three official versions (English, French, German). A version in any other language made by translation under the responsibility of a CEN member into its own language and notified to the Central Secretariat has the same status as the official versions.

CEN members are the national standards bodies of Austria, Belgium, Cyprus, Czech Republic, Denmark, Estonia, Finland, France, Germany, Greece, Hungary, Iceland, Ireland, Italy, Latvia, Lithuania, Luxembourg, Malta, Netherlands, Norway, Poland, Portugal, Romania, Slovakia, Slovenia, Spain, Sweden, Switzerland and United Kingdom.

[SIST EN 14957:2007](https://standards.iteh.ai/catalog/standards/sist/3f53bdba-89bd-4ba4-8909-50c2eca2257e/sist-en-14957-2007)

<https://standards.iteh.ai/catalog/standards/sist/3f53bdba-89bd-4ba4-8909-50c2eca2257e/sist-en-14957-2007>



EUROPEAN COMMITTEE FOR STANDARDIZATION  
COMITÉ EUROPÉEN DE NORMALISATION  
EUROPÄISCHES KOMITEE FÜR NORMUNG

Management Centre: rue de Stassart, 36 B-1050 Brussels

## Contents

	Page
Foreword.....	4
Introduction .....	5
1 Scope .....	6
2 Normative references .....	6
3 Terms, definitions and description .....	7
3.1 Terms and definitions .....	7
3.2 Description .....	8
4 List of significant hazards .....	9
4.1 General.....	9
4.2 Mechanical hazards .....	9
4.3 Electrical hazards .....	10
4.4 Thermal hazards .....	11
4.5 Chemical hazards .....	11
4.6 Hazards generated by neglecting hygiene principles in machine design.....	11
4.7 Hazards generated by neglecting ergonomic principles.....	11
4.8 Hazard from loss of stability.....	11
5 Safety and hygiene requirements and/or protective measures.....	11
5.1 General.....	11
5.2 Mechanical hazards .....	12
5.3 Electrical hazards .....	15
5.4 Thermal hazards .....	16
5.5 Chemical hazards .....	16
5.6 Hygiene .....	16
5.7 Ergonomics .....	16
5.8 Hazard from loss of stability.....	16
6 Verifications of safety and hygiene requirements and/or protective measures.....	17
7 Instruction for use .....	17
7.1 General.....	17
7.2 Instruction handbook .....	17
7.3 Marking .....	19
Annex A (normative) Noise test code for dishwashing machines with conveyor (Grade 2) .....	20
A.1 Emission sound pressure level determination.....	20
A.2 Installation and mounting conditions.....	20
A.3 Operating conditions.....	20
A.4 Measurement.....	21
A.5 Measurement uncertainties .....	21
A.6 Information to be recorded .....	21
A.7 Information to be reported .....	21
A.8 Declaration and verification of noise emission values.....	21
Annex ZA (informative) Relationship between this European Standard and the Essential Requirements of EU Directive 98/37/EC .....	23
Bibliography .....	24

## Figures

Figure 1 — Types of dishwashing machines .....	9
Figure 2 — Hazards zones .....	10
Figure 3 — Flight type machine – Zone 1 .....	12
Figure 4 — Reciprocating rack conveyor device .....	13
Figure 5 — Safety distance for a flight type machine .....	14
Figure 6 — Safety distance for a rack conveyor type machine .....	14
Figure A.1 — Microphone positions .....	20

## Tables

Table 1 — Methods of verifications .....	17
--	----

# iTeh STANDARD PREVIEW (standards.iteh.ai)

SIST EN 14957:2007

<https://standards.iteh.ai/catalog/standards/sist/3f53bdba-89bd-4ba4-8909-50c2eca2257e/sist-en-14957-2007>

## Foreword

This European Standard (EN 14957:2006) has been prepared by Technical Committee CEN/TC 153 “Food processing machinery — Safety and hygiene specifications”, the secretariat of which is held by DIN.

This European Standard shall be given the status of a national standard, either by publication of an identical text or by endorsement, at the latest by May 2007, and conflicting national standards shall be withdrawn at the latest by May 2007.

This European Standard has been prepared under a mandate given to CEN by the European Commission and the European Free Trade Association, and supports essential requirements of EU Directives.

For relationship with EU Directives, see informative Annex ZA, which is an integral part of this European Standard.

According to the CEN/CENELEC Internal Regulations, the national standards organizations of the following countries are bound to implement this European Standard: Austria, Belgium, Cyprus, Czech Republic, Denmark, Estonia, Finland, France, Germany, Greece, Hungary, Iceland, Ireland, Italy, Latvia, Lithuania, Luxembourg, Malta, Netherlands, Norway, Poland, Portugal, Romania, Slovakia, Slovenia, Spain, Sweden, Switzerland and United Kingdom.

## iTeh STANDARD PREVIEW (standards.iteh.ai)

[SIST EN 14957:2007](https://standards.iteh.ai/catalog/standards/sist/3f53bdba-89bd-4ba4-8909-50c2eca2257e/sist-en-14957-2007)

<https://standards.iteh.ai/catalog/standards/sist/3f53bdba-89bd-4ba4-8909-50c2eca2257e/sist-en-14957-2007>

## Introduction

This European Standard is a type C standard as stated in EN ISO 12100.

The machinery concerned and the extent to which hazards, hazardous situations and events are covered are indicated in the scope of this European Standard.

When provisions of this type C standard are different from those which are stated in type B standards, the provisions of this type C standard take precedence over the provisions of the other standards, for machines that have been designed and built according to the provisions of this type C standard.

## iTeh STANDARD PREVIEW (standards.iteh.ai)

[SIST EN 14957:2007](https://standards.iteh.ai/catalog/standards/sist/3f53bdba-89bd-4ba4-8909-50c2eca2257e/sist-en-14957-2007)

<https://standards.iteh.ai/catalog/standards/sist/3f53bdba-89bd-4ba4-8909-50c2eca2257e/sist-en-14957-2007>

## 1 Scope

**1.1** This European Standard applies to multizones dishwashing-machines with passing through motorized belt (flight type) or rack conveyor. In case of flight type, the loading and unloading areas are part of the machine.

The machines covered by this European Standard are intended for washing, rinsing and optionally drying the dishes and the kitchen utensils, used in food and catering premises such as restaurants, hotels etc.

This European Standard applies to dishwashing machines with conveyor with a linear speed less than or equal to 5 m/min for the dishes and kitchen utensils.

NOTE Normally the total power of these machines is less than 200 kW.

This European Standard deals with all significant hazards, hazardous situations and events relevant to dishwashing machines with conveyor, when they are used as intended and under the conditions foreseen by the manufacturer (see Clause 4).

This European Standard deals with the hazards which can arise during commissioning, operation, maintenance and decommissioning of the machine.

When drawing up this European Standard the following assumptions were made:

- only trained adult persons operate the machines;
- the machines are used in adequately illuminated areas.

This European Standard, referring for electrical safety to EN 60204-1 with criteria that can be applied to different designs and variants, is mainly intended for machines manufactured in small series.

**1.2** This European Standard does not apply to:

- separate mechanical loading and unloading conveyors;
- chemical dosing devices which are not incorporated into the machine;
- steam generators;
- gas heating equipment.

**1.3** Noise is not considered to be a significant hazard for these machines. This does not mean that the manufacturer of these machines is absolved from reducing noise and making a noise declaration. Therefore a noise test code is included in Annex A.

**1.4** This European Standard is not applicable to dishwashing-machines with conveyor which are manufactured before the date of publication of this European Standard by CEN.

## 2 Normative references

The following referenced documents are indispensable for the application of this document. For dated references, only the edition cited applies. For undated references, the latest edition of the referenced document (including any amendments) applies.

EN 294:1992, *Safety of machinery — Safety distance to prevent danger zones being reached by the upper limbs*

EN 349, *Safety of machinery — Minimum gaps to avoid crushing of parts of the human body*



- EN 614-1, *Safety of machinery — Ergonomic design principles — Part 1: Terminology and general principles*
- EN 953:1997, *Safety of machinery — Guards — General requirements for the design and construction of fixed and movable guards*
- EN 954-1:1996, *Safety of machinery — Safety-related parts of control systems — Part 1: General principles for design*
- EN 1088:1995, *Safety of machinery — Interlocking devices associated with guards — Principles for design and selection*
- EN 1672-2, *Food processing machinery — Basic concepts — Part 2: Hygiene requirements*
- EN 1760-2, *Safety of machinery — Pressure sensitive protective devices — Part 2: General principles for the design and testing of pressure sensitive edges and pressure sensitive bars*
- EN 60204-1, *Safety of machinery — Electrical equipment of machines — Part 1: General requirements (IEC 60204-1:2005 modified)*
- EN 60529:1991, *Degrees of protection provided by enclosures (IP code) (IEC 60529:1989)*
- CLC/TS 61496-2, *Safety of machinery — Electro-sensitive protective equipment — Part 2: Particular requirements for equipment using active opto-electronic protective devices (AOPDs) (IEC 61496-2:1997)*
- EN ISO 3744:1995, *Acoustics — Determination of sound power levels of noise sources using sound pressure — Engineering method in an essentially free field over a reflecting plane (ISO 3744:1994)*
- EN ISO 4871, *Acoustics — Declaration and verification of noise emission values of machinery and equipment (ISO 4871:1996)*
- EN ISO 11201:1995, *Acoustics — Noise emitted by machinery and equipment — Measurement of emission sound pressure levels at a work station and at other specified positions — Engineering method in an essentially free field over a reflecting plane (ISO 11201:1995)*
- EN ISO 12100-1:2003, *Safety of machinery — Basic concepts, general principles for design — Part 1: Basic terminology, methodology (ISO 12100-1:2003)*
- EN ISO 12100-2:2003, *Safety of machinery — Basic concepts, general principles for design — Part 2: Technical principles (ISO 12100-2:2003)*
- EN ISO 13732-1, *Ergonomics of the thermal environment - Methods for the assessment of human responses to contact with surfaces - Part 1: Hot surfaces (ISO 13732-1:2006)*

### 3 Terms, definitions and description

#### 3.1 Terms and definitions

For the purposes of this document, the terms and definitions given in EN ISO 12100-1:2003 and the following apply.

##### 3.1.1

##### **conveyor**

drive mechanism to transport the load through the machine

##### 3.1.2

##### **types of conveyor**

##### 3.1.2.1

##### **type 1**

flight type endless peg conveyor where the dishes are loaded directly to the pegs (see Figure 1b)

**3.1.2.2**

**type 2**

conveyor for racks that can be made of one or two endless chains or reciprocating mechanism (see Figures 1a and 1c)

**3.1.3**

**dishes**

pans, containers, plates, cups etc., used in the professional catering and restaurants

**3.1.4**

**inspection door**

door giving access to the processing zones for cleaning and maintenance

**3.1.5**

**access for technical area**

door or panel giving access to technical areas for repair and/or maintenance

**3.1.6**

**multizone machine**

machine where the different functions (e.g. washing, rinsing, drying) are located in different areas of the machine

**3.2 Description**

A dishwashing machine with conveyor is generally composed of:

— a frame;

— doors giving access to the different zones;

— a motorised belt or rack conveyor;

— a water heating device;

— a water circulation device.

**iTeh STANDARD PREVIEW**  
**(standards.iteh.ai)**  
[SIST EN 14957:2007  
https://standards.iteh.ai/catalog/standards/sist/3f53bdba-89bd-4ba4-8909-50c2eca2257e/sist-en-14957-2007](https://standards.iteh.ai/catalog/standards/sist/3f53bdba-89bd-4ba4-8909-50c2eca2257e/sist-en-14957-2007)

The main different zones can be:

— a loading area;

— a washing compartment;

— a rinsing compartment;

— a drying compartment;

— a vapour exhaust device;

— one or several electrical and/or electronic compartments;

— a control panel;

— dosing device, if any;

— an unloading area.

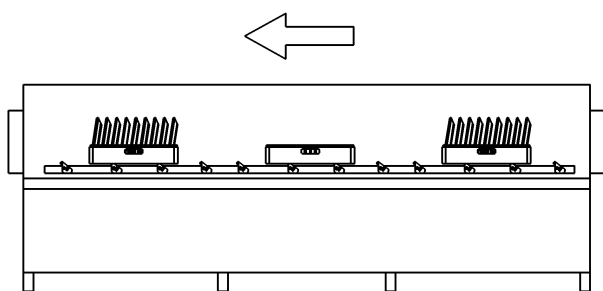

Figure 1a — Racks conveyor type machine

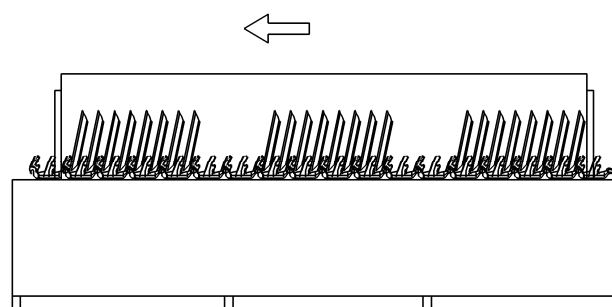

Figure 1b — Flight type machine

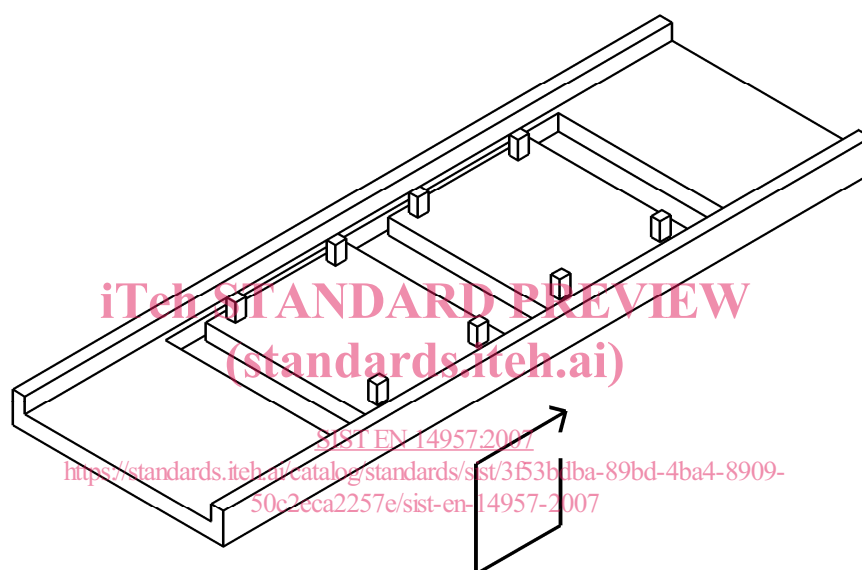

Figure 1c — Reciprocating rack conveyor type device

Figure 1 — Types of dishwashing machines

## 4 List of significant hazards

### 4.1 General

This clause contains all the significant hazards, hazardous situations and events, as far as they are dealt with in this European Standard, identified by risk assessment as significant for dishwashing machines with conveyor, and which require action to eliminate or reduce the risk.

### 4.2 Mechanical hazards

The significant mechanical hazards are:

- crushing hazard;
- shearing hazard;
- drawing-in hazard.