INTERNATIONAL STANDARD



2858

INTERNATIONAL ORGANIZATION FOR STANDARDIZATION • МЕЖДУНАРОДНАЯ ОРГАНИЗАЦИЯ ПО СТАНДАРТИЗАЦИИ • ORGANISATION INTERNATIONALE DE NORMALISATION

End-suction centrifugal pumps for chemical liquids (rating 16 bar) – Designation, nominal duty point and dimensions

First edition – 1973-12-01

UDC 621.671

Ref. No. ISO 2858-1973 (E)

Descriptors: pumps, centrifugal pumps, dimensions, characteristics, ratings.

Price based on 2 pages

FOREWORD

ISO (the International Organization for Standardization) is a worldwide federation of national standards institutes (ISO Member Bodies). The work of developing International Standards is carried out through ISO Technical Committees. Every Member Body interested in a subject for which a Technical Committee has been set up has the right to be represented on that Committee. International organizations, governmental and non-governmental, in liaison with ISO, also take part in the work.

Draft International Standards adopted by the Technical Committees are circulated to the Member Bodies for approval before their acceptance as International Standards by the ISO Council.

International Standard ISO 2858 was drawn up by Technical Committee ISO/TC 115, *Pumps*, and circulated to the Member Bodies in July 1972.

It has been approved by the Member Bodies of the following countries :

Austria	Israel	Spain
Belgium	Italy	Sweden
Egypt, Arab Rep. of	Netherlands	Switzerland
France	New Zealand	Thailand
Germany	Norway	Turkey
Hungary	Portugal	United Kingdom
India	Romania	U.S.S.R.
Ireland	South Africa, Rep. of	

The Member Bodies of the following countries expressed disapproval of the document on technical grounds :

Australia
Czechoslovakia
Japan
U.S.A.

End-suction centrifugal pumps for chemical liquids (rating 16 bar) – Designation, nominal duty point and dimensions

1 SCOPE AND FIELD OF APPLICATION¹⁾

This International Standard specifies the principal dimensions and nominal duty point of end-suction centrifugal pumps having a maximum operating rating of 16 bar.²⁾

2 REFERENCES

ISO/R 228, *Pipe threads where pressure-tight joints are not made on the threads (1/8 inch to 6 inches).*

ISO/R 496, *Shaft heights for driving and driven machines.*

ISO/R 775, *Cylindrical and 1/10 conical shaft ends.*

ISO 3069, *End-suction centrifugal pumps – Dimensions of cavities for mechanical seals and for soft packing.*³⁾ (Supplement to this International Standard.)

NOTE – ISO/R 2084 can be used for the dimensions of flanges.

3 DESIGNATION

The pump designation comprises three numbers : the first corresponds to the inlet diameter, the second to the outlet diameter and the third to the nominal diameter of the impeller.

Example of designation

A centrifugal pump with an inlet diameter of 80 mm, an outlet diameter of 50 mm and a nominal impeller diameter of 250 mm is designated 80-50-250.

4 NOMINAL DUTY POINT AND DIMENSIONS

See figure below and table on page 2.

5 STATIC TEST PRESSURE

Static test pressure shall be 1,5 times the maximum discharge pressure but shall not exceed 24 bar. The relation between cold test pressure and hot operating pressure shall be the subject of agreement between manufacturer and user.

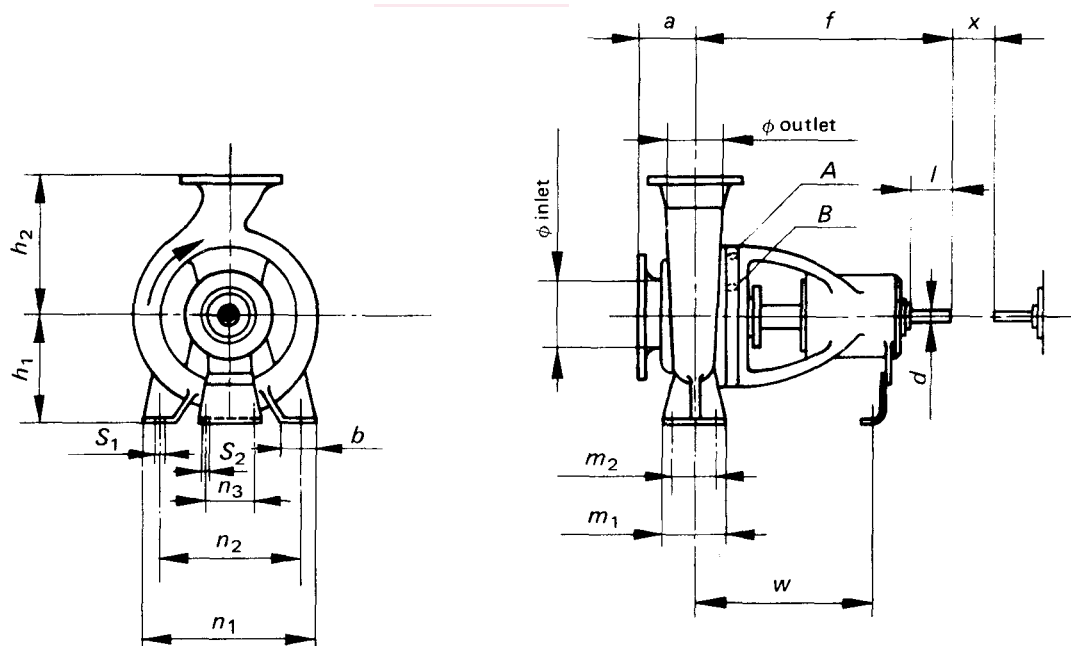

NOTE – Tapping points

All connections shall be in accordance with ISO/R 228.

A : Connection for cooling or heating supply to be 3/8 in.

B : Stuffing box tapping points to be as large as possible but not to exceed 1/2 in.

1) The manufacturer shall be consulted about the temperature limitation.

2) 1 bar = 0,1 MPa.

3) At present at the stage of draft.