

INTERNATIONAL
STANDARD

ISO
5747

Second edition
1995-11-15

**Pliers and nippers — Lever assisted side
cutting pliers, end and diagonal cutting
nippers — Dimensions and test values**

iTeh STANDARD PREVIEW

*(Pincés et tenailles — Pincés articulées coupantes de côté, coupantes en
bout et coupantes diagonale — Dimensions et valeurs d'essai)*

ISO 5747:1995

<https://standards.itih.ai/catalog/standards/sist/eb2c4f24-e26a-4a28-b5f8-105be614bb40/iso-5747-1995>



Reference number
ISO 5747:1995(E)

Foreword

ISO (the International Organization for Standardization) is a worldwide federation of national standards bodies (ISO member bodies). The work of preparing International Standards is normally carried out through ISO technical committees. Each member body interested in a subject for which a technical committee has been established has the right to be represented on that committee. International organizations, governmental and non-governmental, in liaison with ISO, also take part in the work. ISO collaborates closely with the International Electrotechnical Commission (IEC) on all matters of electrotechnical standardization.

Draft International Standards adopted by the technical committees are circulated to the member bodies for voting. Publication as an International Standard requires approval by at least 75 % of the member bodies casting a vote.

International Standard ISO 5747 was prepared by Technical Committee ISO/TC 29, *Small tools*.

This second edition cancels and replaces the first edition (ISO 5747:1984), which has been technically revised. In particular, modification of figure 1 where the opening of the jaws is designated G and the opening of the cutting jaws by G_1 ; in addition, minimum values of G_1 have been added to table 1 and there are modifications to figure 3 (dimension L_1) and to table 5 (dimension T_1).

© ISO 1995

All rights reserved. Unless otherwise specified, no part of this publication may be reproduced or utilized in any form or by any means, electronic or mechanical, including photocopying and microfilm, without permission in writing from the publisher.

International Organization for Standardization
Case Postale 56 • CH-1211 Genève 20 • Switzerland

Printed in Switzerland

Pliers and nippers — Lever assisted side cutting pliers, end and diagonal cutting nippers — Dimensions and test values

1 Scope

This International Standard specifies the principal dimensions of lever assisted side cutting pliers and end and diagonal cutting nippers, as well as the test values for the pliers and nippers to verify their functioning, according to ISO 5744. General technical requirements are given in ISO 5743.

The lever assisted pliers in this International Standard are only examples and are not intended to affect the manufacturer's design.

2 Normative references

The following standards contain provisions which, through reference in this text, constitute provisions of this International Standard. At the time of publication, the editions indicated were valid. All standards are subject to revision, and parties to agreements based on this International Standard are encouraged to investigate the possibility of applying the most recent editions of the standards indicated below. Members of IEC and ISO maintain registers of currently valid International Standards.

ISO 5743:1988, *Pliers and nippers — General technical requirements*.

ISO 5744:1988, *Pliers and nippers — Methods of test*.

3 Dimensions and test values

3.1 Lever assisted side cutting pliers for hard wire

See figure 1 and tables 1 and 2.

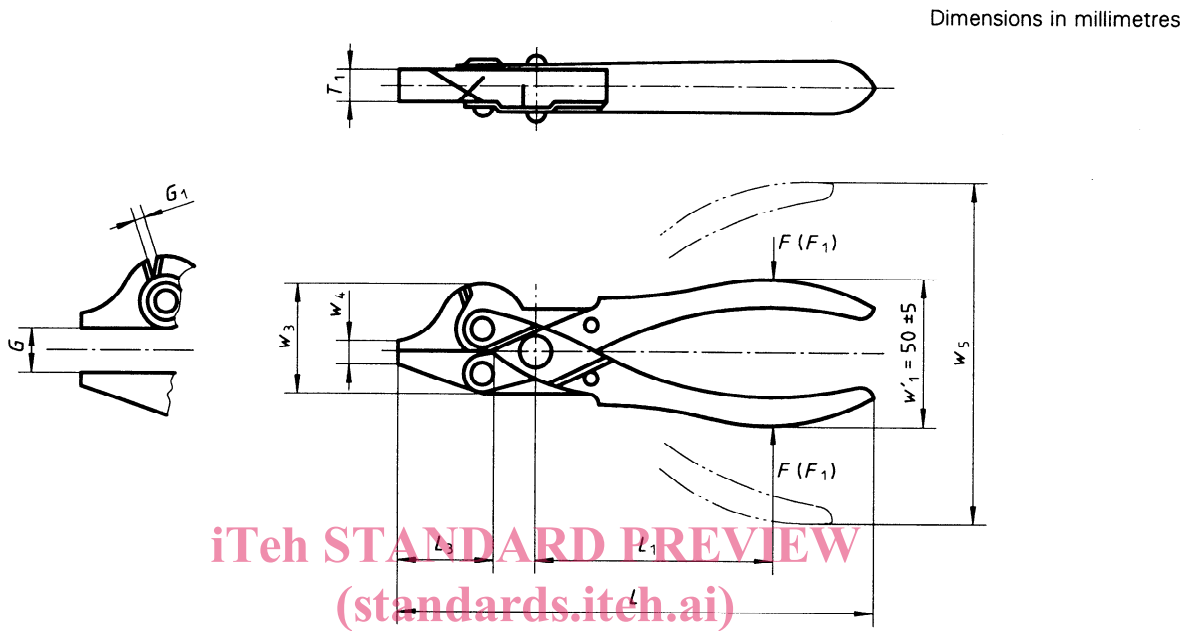

iTeh STANDARD PREVIEW
(standards.itih.ai)

Figure 1:1995

<https://standards.itih.ai/catalog/standards/sist/eb2c4f24-e26a-4a28-b5f8-105be614bb40/iso-5747-1995>

Table 1

Dimensions in millimetres

L	L_3 max.	w_3 max.	w_4 max.	G min.	G_1 min.	T_1 max.
125 ± 6	25	32	4	10	3,2	6
140 ± 7	28	36	4,5	11	3,5	8
160 ± 8	32	40	5	12	4,5	10
200 ± 10	40	50	6	16	7,1	16

Cutting pliers shall be tested in accordance with ISO 5744.

After the load test, the permanent set s shall not exceed the value given in table 2. If the distance L_1 is not suitable for the load test the following formula may be applied:

$$F' = \frac{F \times L_1}{L'_1}$$

where

- F' is the load which is not given in table 2;
- F is the load given in table 2;
- L_1 is the distance from the centre of the joint rivet to the applied load given in table 2;
- L'_1 is the measured distance from the centre of the joint rivet to the applied load.

The maximum cutting force (F_1) and diameter (D) of the test wire shall not exceed the values given in table 2.

Table 2

L	L_1	Lever ratio ¹⁾	Cutting test		Load test	
			Diameter of hard test wire D ²⁾	Maximum cutting force $F_{1,max}$	Load F	Maximum permanent set s_{max} ³⁾
			mm	N	N	mm
125	60	15	1,25	260	360	1
140	75	15	1,4	310	450	1
160	90	15	1,6	370	540	2
200	125	15	2	530	750	3

1) Lever ratio = $\frac{w_5 - w'_1}{G}$
 2) Data for hard test wire are given in ISO 5744.
 3) $s = w_1 - w_2$ (See ISO 5744.)

Pliers having a lever ratio differing from the values given in table 2 may be checked for compliance by the following formula:

$$F'_1 = \frac{F_2 \times 2 \times G}{w_5 - w'_1}$$

where

- F'_1 is the maximum cutting force which is not given in table 2;
- F_2 is the cutting force of hard test wire given in ISO 5744;
- 2 is the correction factor for hard test wire;
- G is the measured opening of the jaws;
- w'_1 is the measured width of the handles when closed;
- w_5 is the measured width of the handles when open.

3.2 Lever assisted end cutting nippers for hard wire

See figure 2 and tables 3 and 4.

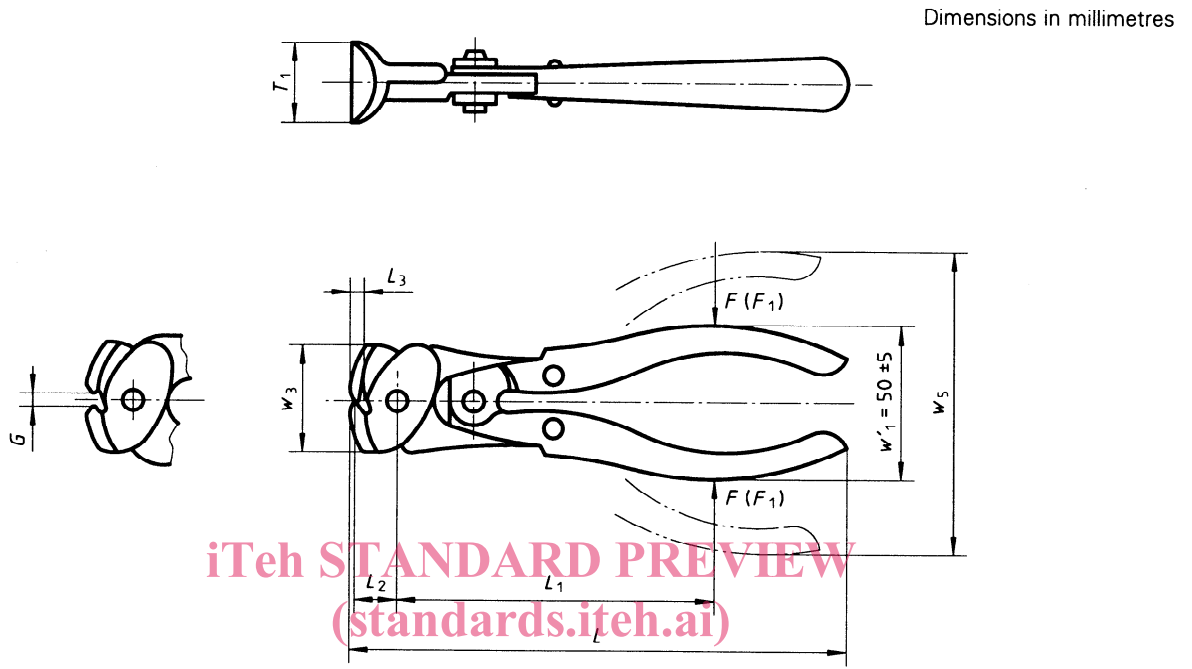

ISO 5747:1995
Figure 2
<https://standards.itih.ai/catalog/standards/sist/eb2c4f24-e26a-4a28-b5f8-105be614bb40/iso-5747-1995>

Table 3

Dimensions in millimetres

L	L_3 max.	w_3 max.	G min.	T_1 max.
160 ± 8	8	40	3,2	25

Cutting nippers shall be tested in accordance with ISO 5744.

After the load test, the permanent set (s) shall not exceed the value given in table 4. If the distance L_1 is not suitable for the load test the following formula may be applied:

$$F' = \frac{F \times L_1}{L'_1}$$

where

F' is the load which is not given in table 4;

F is the load given in table 4;

L_1 is the distance from the centre of the joint rivet to the applied load given in table 4;

L'_1 is the measured distance from the centre of the joint rivet to the applied load.

The maximum cutting force (F_1) and diameter (D) of the test wire shall not exceed the values given in table 4.

Table 4

L	L_1	L_2	Lever ratio ¹⁾	Cutting test		Load test	
				Diameter of hard test wire D ²⁾	Maximum cutting force $F_{1,max}$	Load F	Maximum permanent set s_{max} ³⁾
mm	mm	mm		mm	N	N	mm
160	112	15	14	1,6	400	670	2

1) Lever ratio = $\frac{w_5 - w'_1}{G}$

2) Data for hard test wire are given in ISO 5744.

3) $s = w_1 - w_2$ (See ISO 5744.)

iTeh STANDARD PREVIEW
(standards.iteh.ai)

[ISO 5747:1995](https://standards.iteh.ai/catalog/standards/sist/eb2c4f24-e26a-4a28-b5f8-105be614bb40/iso-5747-1995)

<https://standards.iteh.ai/catalog/standards/sist/eb2c4f24-e26a-4a28-b5f8-105be614bb40/iso-5747-1995>

Nippers having a lever ratio differing from the value given in table 4 may be checked for compliance by the following formula:

$$F'_1 = \frac{F_2 \times 2 \times G}{w_5 - w'_1}$$

where

F'_1 is the maximum cutting force which is not given in table 4;

F_2 is the cutting force of hard test wire given in ISO 5744;

2 is the correction factor for hard test wire;

G is the measured opening of the jaws;

w'_1 is the measured width of the handles when closed;

w_5 is the measured width of the handles when open.

3.3 Lever assisted diagonal cutting nippers for hard wire

See figure 3 and tables 5 and 6.

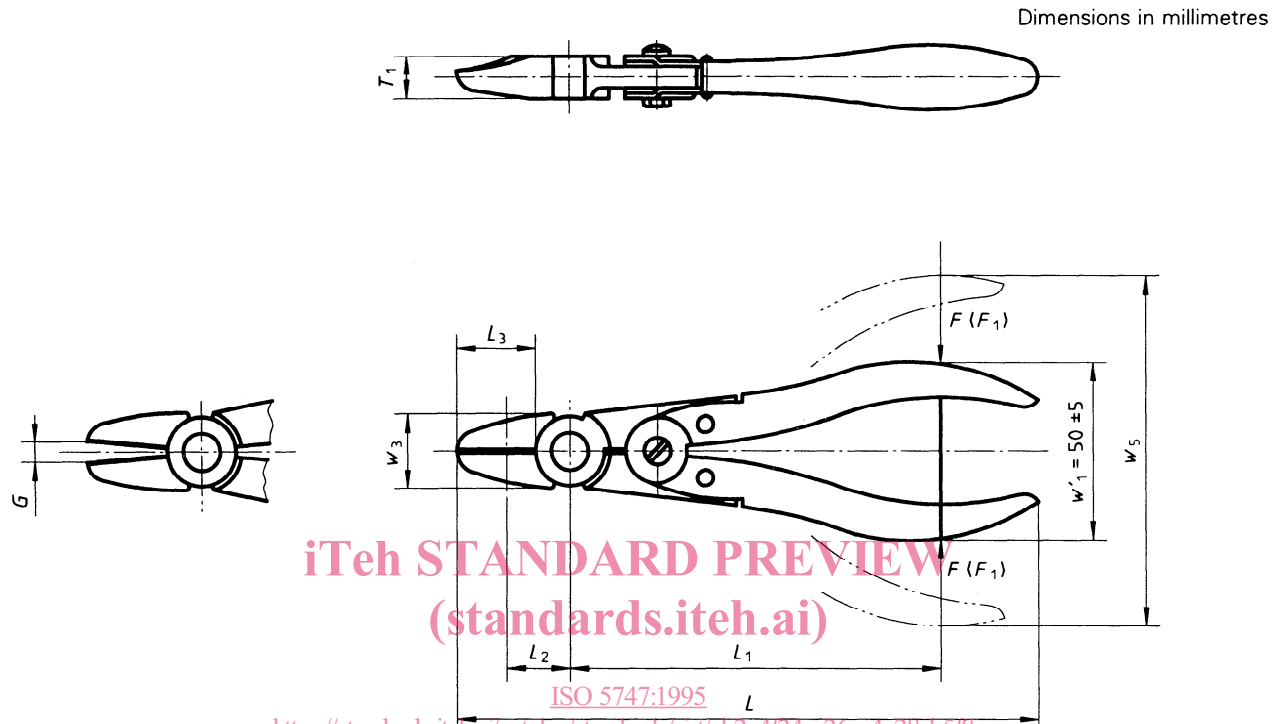

ISO 5747:1995
<https://standards.iteh.ai/catalog/standards/sist/eb2c4f24-e26a-4a28-b5f8-105be614bb40/iso-5747-1995>

Figure 3

Table 5

Dimensions in millimetres

L	L_3 max.	w_3 max.	G min.	T_1 max.
140 ± 7	20	25	5	12
160 ± 8	20	25	5	14

Cutting nippers shall be tested in accordance with ISO 5744.

After the load test, the permanent set (s) shall not exceed the value given in table 6. If the distance L_1 is not suitable for the load test the following formula may be applied:

$$F' = \frac{F \times L_1}{L'_1}$$

where

F' is the load which is not given in table 6;

F is the load given in table 6;

L_1 is the distance from the centre of the joint rivet to the applied load given in table 6;

L'_1 is the measured distance from the centre of the joint rivet to the applied load.

The maximum cutting force (F_1) and diameter (D) of the test wire shall not exceed the values given in table 6.

Table 6

L	L_1	L_2	Lever ratio ¹⁾	Cutting test		Load test	
				Diameter of hard test wire D ²⁾	Maximum cutting force $F_{1,max}$	Load F	Maximum permanent set s_{max} ³⁾
mm	mm	mm		mm	N	N	mm
140	95	12	12	1,4	310	450	2
160	112	15	10	1,6	400	670	2

1) Lever ratio = $\frac{w_5 - w'_1}{G}$
 2) Data for hard test wire are given in ISO 5744.
 3) $s = w_1 - w_2$ (See ISO 5744.)

<https://standards.iteh.ai/catalog/standards/sist/eb2c4f24-e26a-4a28-b5f8-105be614bb40/iso-5747-1995>

Nippers having a lever ratio differing from the value given in table 6 may be checked for compliance by the following formula:

$$F'_1 = \frac{F_2 \times 2 \times G}{w_5 - w'_1}$$

where

F'_1 is the maximum cutting force which is not given in table 6;

F_2 is the cutting force of hard test wire given in ISO 5744;

2 is the correction factor for hard test wire;

G is the measured opening of the jaws;

w'_1 is the measured width of the handles when closed;

w_5 is the measured width of the handles when open.