

---

---

**Plastics piping systems — Unplasticized  
poly(vinyl chloride) (PVC-U)  
end-load-bearing double-socket joints —  
Test method for leaktightness and strength  
while subjected to bending and internal  
pressure**

iTeh STANDARD PREVIEW

*Systèmes de canalisations en plastiques — Double manchon en  
poly(chlorure de vinyle) non plastifié (PVC-U) résistant à la traction  
axiale — Méthode d'essai d'étanchéité et de la résistance en traction, avec  
solicitation en flexion et pression interne*

<https://standards.itih.ai/catalog/standards/sist/c71c3e48-eebc-4187-b2fd-9f0a76905e7e/iso-13783-1997>



## Foreword

ISO (the International Organization for Standardization) is a worldwide federation of national standards bodies (ISO member bodies). The work of preparing International Standards is normally carried out through ISO technical committees. Each member body interested in a subject for which a technical committee has been established has the right to be represented on that committee. International organizations, governmental and non-governmental, in liaison with ISO, also take part in the work. ISO collaborates closely with the International Electrotechnical Commission (IEC) on all matters of electrotechnical standardization.

Draft International Standards adopted by the technical committees are circulated to the member bodies for voting. Publication as an International Standard requires approval by at least 75 % of the member bodies casting a vote.

International Standard ISO 13783 was prepared by the European Committee for Standardization (CEN) in collaboration with ISO Technical Committee TC 138, *Plastics pipes, valves and fittings for the transport of fluids*, Subcommittee SC 2, *Plastics pipes and fittings for water supplies*, in accordance with the Agreement on technical cooperation between ISO and CEN (Vienna Agreement).

iTeh STANDARD PREVIEW

(standards.iteh.ai)

ISO 13783:1997

ent-01-technical-cooperation-between-ISO-and-CEN-4187-b2fd-9f0a76905e7e/iso-13783-1997

© ISO 1997

All rights reserved. Unless otherwise specified, no part of this publication may be reproduced or utilized in any form or by any means, electronic or mechanical, including photocopying and microfilm, without permission in writing from the publisher.

International Organization for Standardization

Case postale 56 • CH-1211 Genève 20 • Switzerland

Internet central@iso.ch

X.400 c=ch; a=400net; p=iso; o=isocs; s=central

Printed in Switzerland

## Foreword

The text of EN ISO 13783:1997 has been prepared by Technical Committee CEN/TC 155 "Plastics piping systems and ducting systems", the secretariat of which is held by NNI, in collaboration with Technical Committee ISO/TC 138 "Plastics pipes, fittings and valves for the transport of fluids".

The material-dependent parameters and/or performance requirements are incorporated in the System Standard(s) concerned.

This standard is one of a series of standards on test methods which support System Standards for plastics piping systems and ducting systems.

This European Standard shall be given the status of a national standard, either by publication of an identical text or by endorsement, at the latest by March 1998, and conflicting national standards shall be withdrawn at the latest by March 1998.

According to the CEN/CENELEC Internal Regulations, the national standards organizations of the following countries are bound to implement this European Standard: Austria, Belgium, Czech\_Republic, Denmark, Finland, France, Germany, Greece, Iceland, Ireland, Italy, Luxembourg, Netherlands, Norway, Portugal, Spain, Sweden, Switzerland and the United Kingdom.

[ISO 13783:1997](https://standards.iteh.ai/catalog/standards/sist/c71c3e48-eebc-4187-b2fd-9f0a76905e7e/iso-13783-1997)

<https://standards.iteh.ai/catalog/standards/sist/c71c3e48-eebc-4187-b2fd-9f0a76905e7e/iso-13783-1997>

**iTeh STANDARD PREVIEW**  
This page intentionally left blank  
**(standards.iteh.ai)**

ISO 13783:1997

<https://standards.iteh.ai/catalog/standards/sist/c71c3e48-eebc-4187-b2fd-9f0a76905e7e/iso-13783-1997>

## 1 Scope

This standard specifies a method for testing, while subjected to bending, the leaktightness and strength of assembled end-load-bearing double socket joints of unplasticized poly(vinyl chloride) (PVC-U) which allow a maximum angle of deflection of 3°.

It is applicable to double socket couplers provided with elastomeric sealing rings and locking rings and intended for use with PVC-U pressure pipes (see figure 1).

The method specifies the internal pressure, the method of calculation for the additional bending force and the procedure for the bending test.

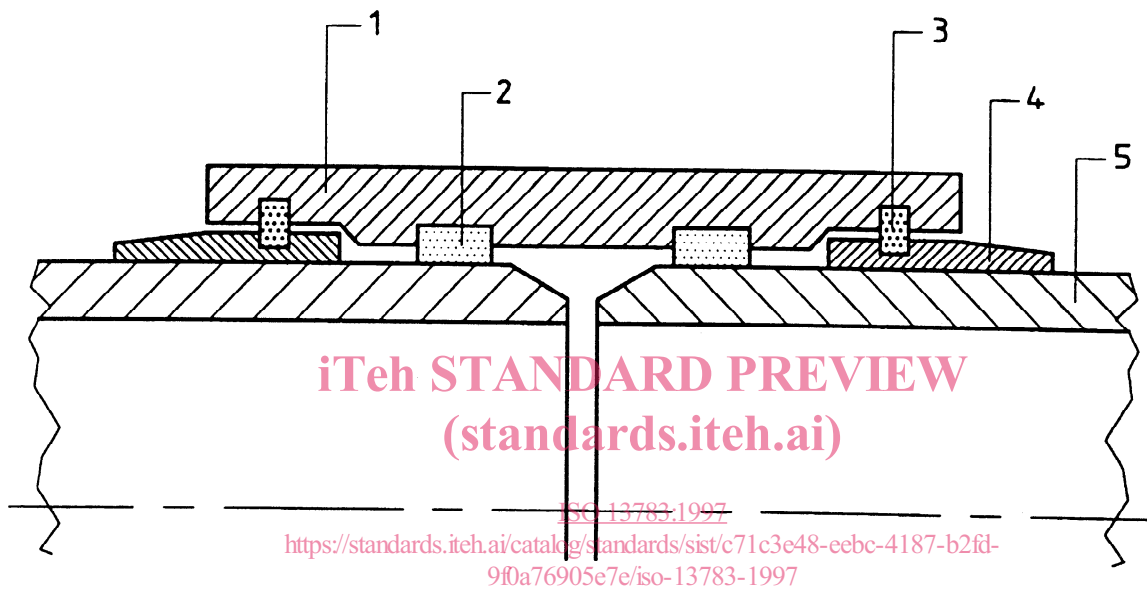

- 1 PVC-U coupling
- 2 Sealing ring
- 3 Locking device
- 4 Solvent cemented PVC-U sleeve
- 5 PVC-U pipe

**Figure 1: Example of end-load-bearing double socket coupler**

## 2 Normative reference

This Standard incorporates by dated or undated reference, provisions from other publications. These normative references are cited at the appropriate places in the text and the publications are listed hereafter. For dated references, subsequent amendments to or revisions of any of these publications apply to this Standard only when incorporated in it by amendment or revision. For undated references the latest edition of the publication referred to applies.

ISO 4065:1996

*Thermoplastics pipes - Universal wall thickness table*

### 3 Principle

A test piece, consisting of PVC-U pipes mounted into a PVC-U double socket coupler, is exposed to a specific cycle of internal hydrostatic pressures for specific test periods and at a specific temperature while the assembly is simultaneously subjected to a lateral bending force.

### 4 Apparatus

**4.1 A pressure control device**, connected to the test piece and capable of applying a variable internal hydrostatic pressure of at least 2,5 times the nominal pressure (PN) of the PVC-U pipe and joint assembly.

**4.2 A vacuum pump**, capable of applying a negative internal pressure of at least -0,8 bar (-0,08 MPa).

**4.3 A loading jig**, capable of applying a horizontal bending force to an assembled test piece while it is subjected to an internal hydrostatic pressure. The jig includes vertical supports equally spaced at  $5d_n$  on either side of the axis of the horizontal force to restrain the test piece so that the horizontal force will induce bending, and horizontal supports beneath the test piece, to enable horizontal axial alignment of the test piece components. The supports have a low friction surface, to minimise inhibition of axial bending.

An example of a test arrangement is shown in figure 2.

The length of the pipe sections and the total length of the test pieces shall conform to the values given in figure 2.

**4.4 Gauges**, for measuring the internal hydrostatic pressure and the applied bending force, each having an accuracy of  $\pm 1\%$  at the measured values.

### 5 Test piece

The test piece shall consist of two PVC-U pipe sections mounted into the PVC-U end-load-bearing double socket coupler to be tested. The assembly shall be carried out in accordance with the instructions of the manufacturer of the double socket coupler.

The pipes and the double socket shall be of the same nominal pressure.

NOTE: The mean outside diameter of the pipes should preferably conform to the minimum specified value, and the socket dimensions (mean inside diameter and the diameter of the groove for housing the sealing ring) should preferably conform to the maximum allowable values stated by the manufacturer in order to have dimensions as close as possible to the extreme limits of their relevant tolerances.

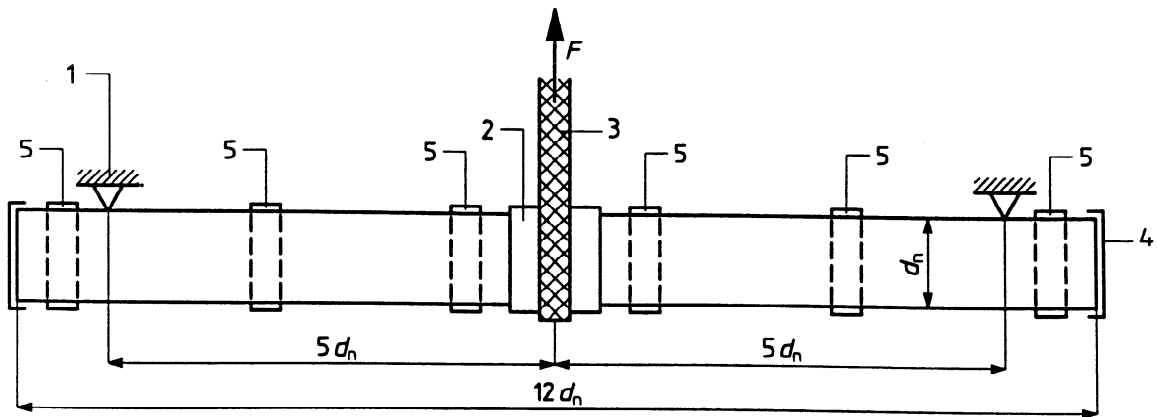

- 1 Supports to oppose the bending force
- 2 End-load-bearing double socket
- 3 Pliable band to apply the force
- 4 End cap
- 5 Supports for the weight of the test piece

Figure 2: Example of assembly and specified lengths (planview)

**iTeh STANDARD PREVIEW**  
(standards.iteh.ai)

**6 Procedure**

6.1 Calculate the bending force  $F$  using the following equation:

ISO 13783:1997  
<https://standards.iteh.ai/catalog/standards/sist/c71c3e48-eebc-4187-b2fd-910209557600/iso-13783-1997>

$$F = 0,1 \left( \frac{d_n e_n}{d_n} \right)^2 \times (\pi \sigma e_n d_{n,m} F_e)$$

where:

$d_n$  is the nominal outside diameter of the PVC-U pipes, in millimetres;

$e_n$  is the nominal wall thickness of the PVC-U pipes, in millimetres;

$\sigma$  is the resulting stress, due to the simultaneous effect of bending and internal pressure it shall be 20 MPa (N/mm<sup>2</sup>);

$$d_{n,m} = d_n - e_n;$$

$F_e$  is the force, in newtons, acting axially on the end caps and given by the following equation:

$$F_e = p_i \left( \frac{\pi d_i^2}{4} \right)$$

where:

$p_i$  is the internal water pressure in MPa, which shall be 0,1 times the value of PN;

$d_i$  is the calculated inside diameter of the PVC-U pipe, i.e.  $(d_n - 2e_n)$ .

NOTE: Some values calculated for  $F$ , based on PVC-U pipes, are given in table 1.

**Table 1: Calculated values for the bending force,  $F$**

PN	Bending force $F$ on the double socket coupler (in newtons)					
	6,0	6,3	8	10	12,5	16
$d_n$	S 20,8	S 20 *)	S 16	S 12,5	S 10	S 8
110	1179	1217	1510	1833	2280	2748
125	1555	1594	1975	2385	2930	3489
160	2511	2640	3155	3955	4816	5738
200	3867	4013	5012	6127	7500	8989
250	6078	6376	7763	9540	11592	13956
315	9588	9923	12321	14817	18413	22235
355	12300	12647	15587	18797	23377	28284
400	15468	16050	19830	23654	29797	35765
500	24311	25220	30778	37893	46622	56064
630	38353	39690	48939	59602	73651	

\*) S is the pipe series conforming to ISO 4065:1996.

**6.2** Lay the assembled test piece on the supports, ensuring that the pipes and the coupler are in axial alignment (see figure 2).

**6.3** Fill the test piece with water at  $(20 \pm 5) ^\circ\text{C}$  and release all air. Allow the assembly to condition for 60 min to ensure equalization of temperature.

**6.4** Carry out the procedure given in 6.5 at any ambient temperature between  $15 ^\circ\text{C}$  and  $25 ^\circ\text{C}$  while maintaining this ambient temperature within  $\pm 2 ^\circ\text{C}$  and examining the joints for leakage during the whole test cycle.

**6.5** Carry out the following test procedure in accordance with the schematic arrangement shown in figure 3, which is not intended to require strictly linear rates of change in pressure or force, and by maintaining each static pressure and bending force within  $\pm 5\%$ .



At A: increase the water pressure over a period of 5 min to 1 times [PN], and maintain this pressure for 5 min.

At B: increase the water pressure over a period of 5 min to 2,5 times [PN], and maintain this pressure for 5 min.

At C: reduce the water pressure over a period of 5 min to 1 times [PN].

At D: apply the calculated value of the bending force,  $F$ , in the horizontal plane over a period of 5 min whilst maintaining the internal pressure of 1 times [PN].

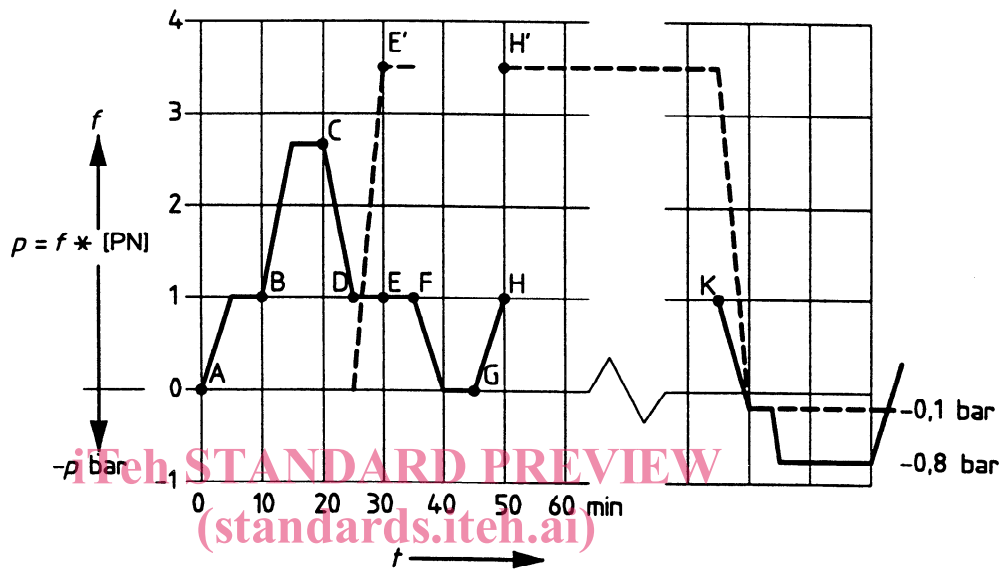

ISO 13783:1997

NOTE: The solid line represents the time limits for pressure changes (inclusive of constant values) and the dotted line represents the bending force,  $F$ , (exclusive of values). The lines do not infer that the rates of change of pressure or force are strictly linear.

**Figure 3: Schematic hydrostatic pressure test regime with bending**

At E: maintain the water pressure at 1 times [PN] for a further period of 5 min whilst maintaining the bending force  $F$ .

At F: reduce the water pressure to atmospheric pressure within 5 min and ensure that the deflection of the pipe is maintained constant for a further period of 5 min.

At G: increase the water pressure within a period of 5 min to 1 times [PN].

At H: adjust the bending force,  $F$ , to its original value. (The angle of deflection will normally be a little greater than at E.)

Repeat the cycle from E to H a further nine times.