

INTERNATIONAL
STANDARD

ISO
4510-2

Second edition
1996-11-15

**Earth-moving machinery —
Service tools —**

Part 2:
Mechanical pullers and pushers
(standards.iteh.ai)

[ISO 4510-2:1996](https://standards.iteh.ai/catalog/standards/sist/49501053/iso-4510-2-1996)

<https://standards.iteh.ai/catalog/standards/sist/49501053/iso-4510-2-1996>
*Engins de terrassement — Outils d'entretien et de dépannage —
Partie 2: Extracteurs mécaniques par traction et par pression*



Reference number
ISO 4510-2:1996(E)

Foreword

ISO (the International Organization for Standardization) is a worldwide federation of national standards bodies (ISO member bodies). The work of preparing International Standards is normally carried out through ISO technical committees. Each member body interested in a subject for which a technical committee has been established has the right to be represented on that committee. International organizations, governmental and non-governmental, in liaison with ISO, also take part in the work. ISO collaborates closely with the International Electrotechnical Commission (IEC) on all matters of electrotechnical standardization.

Draft International Standards adopted by the technical committees are circulated to the member bodies for voting. Publication as an International Standard requires approval by at least 75 % of the member bodies casting a vote.

International Standard ISO 4510-2 was prepared by Technical Committee ISO/TC 127, *Earth-moving machinery*, Subcommittee SC 3, *Operation and maintenance*.

This second edition ~~replaces the first edition~~ (ISO 4510-2:1986), which has been technically revised.

ISO 4510 consists of the following parts, under the general title *Earth-moving machinery — Service tools*:

- *Part 1: Common maintenance and adjustment tools*
- *Part 2: Mechanical pullers and pushers*

Annex A of this part of ISO 4510 is for information only.

© ISO 1996

All rights reserved. Unless otherwise specified, no part of this publication may be reproduced or utilized in any form or by any means, electronic or mechanical, including photocopying and microfilm, without permission in writing from the publisher.

International Organization for Standardization
Case Postale 56 • CH-1211 Genève 20 • Switzerland
Printed in Switzerland

Earth-moving machinery — Service tools —

Part 2:

Mechanical pullers and pushers

1 Scope

This part of ISO 4510 specifies for guidance the types, general requirements and main nominal dimensions of mechanical pullers, attachments and adaptors used for carrying out repair work.

This part of ISO 4510 includes mechanical pullers and push pullers, pulling attachments and adaptors which are commonly used for pulling gears and bearings mounted on the types of earth-moving machinery defined in ISO 6165.

Machine manufacturers should consider

- the usage of these pullers and pushers for carrying out repair work (see for example notes in figures A.1, A.4 and A.5);
- choosing dimensions for machine design from tables 1 to 4, and
- specifying, in suitable manuals as described in ISO 6750, the type of tools to be used for carrying out repair work.

2 Normative references

The following standards contain provisions which, through reference in this text, constitute provisions of this part of ISO 4510. At the time of publication, the editions indicated were valid. All standards are subject to revision, and parties to agreements based on this part of ISO 4510 are encouraged to investigate the possibility of applying the most recent editions of the standards indicated below. Members of IEC and ISO maintain registers of currently valid International Standards.

ISO 4510-1:1987, *Earth-moving machinery — Service tools — Part 1: Common maintenance and adjustment tools.*

ISO 6165:—¹⁾, *Earth-moving machinery — Basic types — Vocabulary.*

ISO 6750:1984, *Earth-moving machinery — Operation and maintenance — Format and content of manuals.*

1) To be published. (Revision of ISO 6165:1987)

3 Types of pullers, attachments and adaptors

3.1 Mechanical pullers

Figure 1 shows types of mechanical puller. These pullers can be used alone (see figure A.1) or in combination with external pulling attachments (see figure A.2) for disassembly operations.

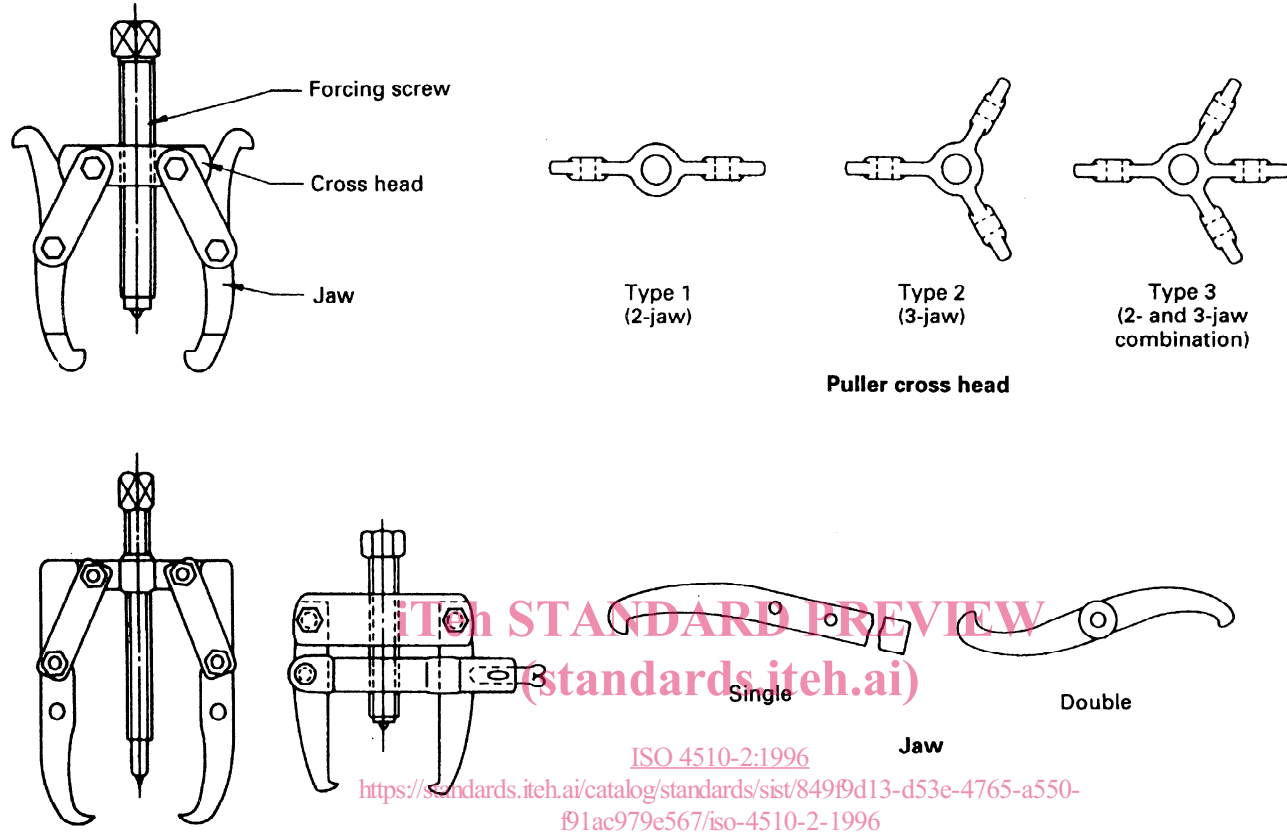

Figure 1

3.2 Push pullers

Figure 2 shows a push puller.

Push pullers can be used alone (see figure A.4) or in combination with internal pulling attachments (see figure A.5) or external pulling attachments (see figure A.6) for removal and installation of gears, bearings, shafts and other press-fitted parts.

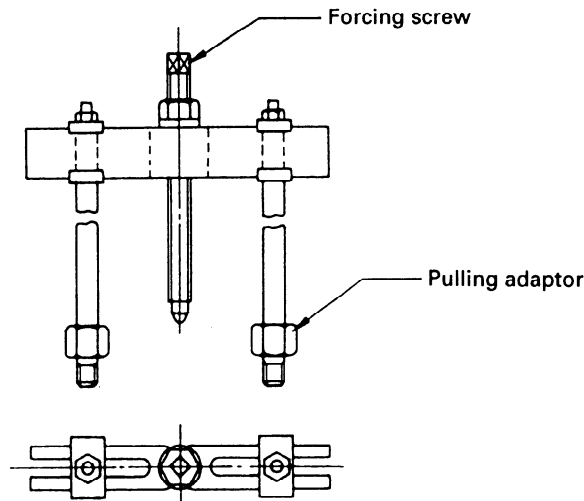

Figure 2

3.3 Pulling attachments

Internal pulling attachments [see figure 3a)] can be used alone (see figure A.3) or in combination with push pullers (see figure A.5) for removal of bearing cups, oil seals, bushes and other parts from blind holes without damage.

External pulling attachments [see figure 3b)] are used in combination with pullers (see figure A.2) or push pullers (see figure A.6) to remove the bearing outer race and other parts where space does not permit the jaws to fit directly behind the parts to be removed.

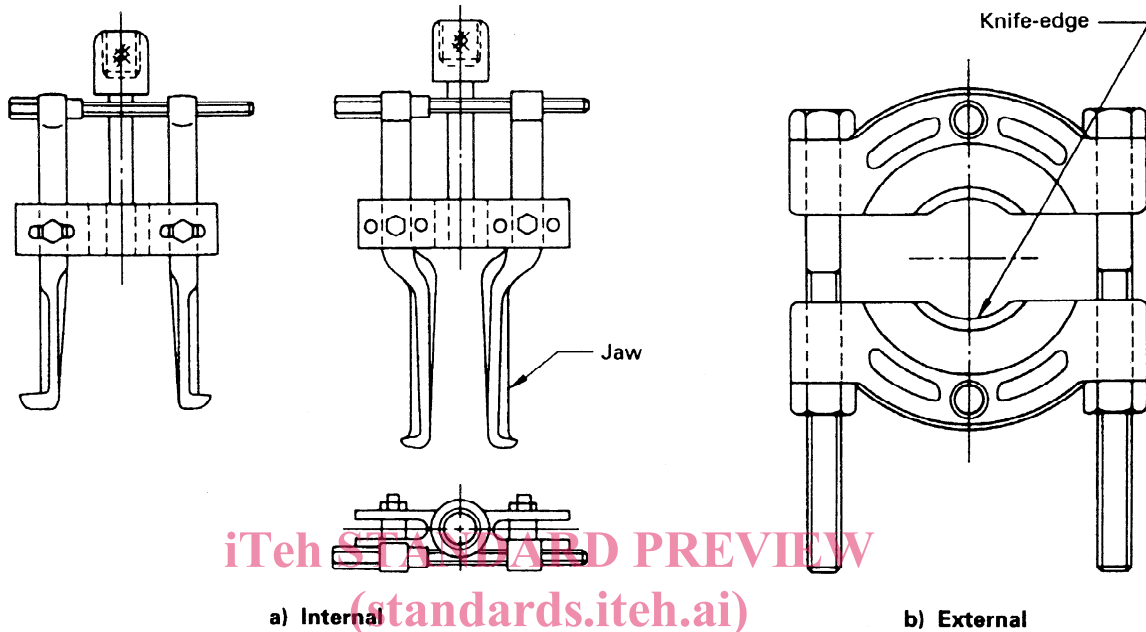

Figure 3
 a) Internal (standards.iteh.ai)
 b) External

ISO 4510-2:1996

<https://standards.iteh.ai/catalog/standards/sist/849f9d13-d53e-4765-a550->

3.4 Pulling adaptor, male and female thread

Pulling adaptors (see figure 4 and figure 2) are used at the ends of the legs of push pullers.

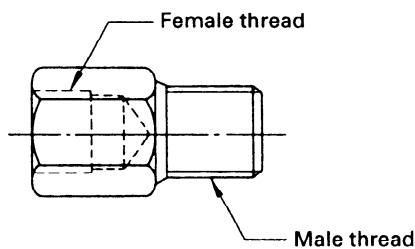

Figure 4

3.5 Step plate adaptor

Step plate adaptors (see figure 5) are used to protect shaft centres from distortion when extreme pressure is applied through the puller screw. These adaptors are also used between the end of the puller screw and the hollow shaft (see figures A.2, A.4 and A.6).

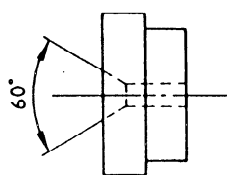

Figure 5

4 General requirements

4.1 Pullers and attachments shall be designed to allow free movement and minimum clearance between the parts.

4.2 The head of the forcing screw and/or its nuts, which are tightened during repair work, shall be either square or hexagonal in shape and of a size suitable for accepting a standard size wrench, as specified in ISO 4510-1.

4.3 The pressure end of the forcing screw shall have a 60° conical point to ensure that loads are applied in the shaft centre.

4.4 The gripping ends of the jaws shall be used to prevent slippage from the gear or bearing being pulled, at any setting within the capacity of the pullers.

4.5 Internal and external pulling attachments shall be suitable for use with push pullers and pullers, respectively, when required.

4.6 Pulling adaptors shall be used with push pullers, where applicable.

4.7 Step plate adaptors shall be used with pullers and push pullers on shaft ends with internal hole or without centre hole.

5 Dimensions

The illustrations in figures 6, 7 and 8 are for the convenience of identification and are not intended to specify the structure (shape, configuration, etc.) of pullers and associated attachments.

NOTE — Inch dimensions are not specified in this part of ISO 4510. Inch dimensions equivalent to the metric dimensions given may only be used when there is a need to reflect local conditions.

5.1 Jaw tips of pullers

ISO 4510-2:1996

<https://standards.iteh.ai/catalog/standards/sist/849f9d13-d53e-4765-a550-96a079500196>

The dimensions of the jaw tips of pullers are given in figure 6 and table 1.

Table 1 — Dimensions of jaw tips of pullers

Dimensions in millimetres

Type No.	Cross head type ¹⁾	Capacity kN	b_1	b_2	b_3	b_4	b_5	b_6	b_7	b_8	b_9	l	R	Use width corresponding to:	
														Push puller type No. ²⁾	Pulling attachment type No. ³⁾
1-1	1, 3	18	120 max.	3	13	5,5	5	6,5	6	15	16	86	—	—	—
1-2	1, 3	44,5	175 max.	6,5	17,5	6	8	9	6,5	16	19	82,5	—	—	1
1-3	1, 3	62,5	265 max.	9,5	24	8	8	9,5	11,5	19	25,5	127	—	—	2, 3
2-1	1, 3	115,5	355 max.	14,5	25,5	14,5	—	—	—	28,5	—	280	—	—	3
2-2	1, 2	156	355 max.	20,5	32,5	14,5	—	—	—	32,5	—	368	—	—	4
2-3	1, 2	222,5	405 max.	27,5	38	24	—	—	—	49,5	—	390	—	—	4, 5
3	—	133,5	225 max. 75 min.	6,5	51	6,5	—	—	—	25,5	—	150	63,5	3	—
4	—	49	150 max. 40 min.	3,5	29,5	6,5	—	—	—	16	—	100	38	1, 2	—

NOTE — l is based on the standard jaw length.

1) See figure 1.

2) See table 2.

3) See table 3.

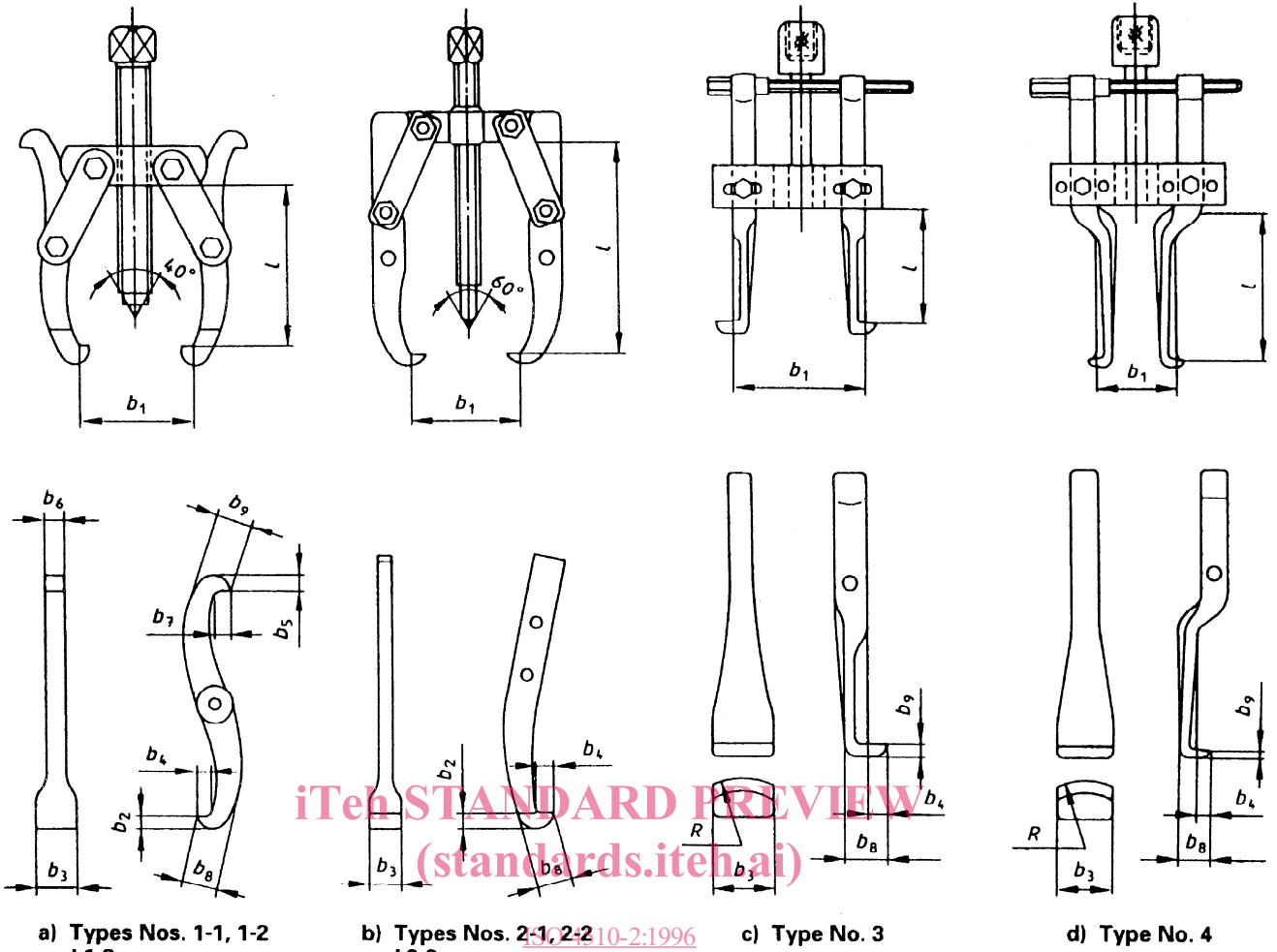

a) Types Nos. 1-1, 1-2 and 1-3

b) Types Nos. 2-1, 2-2, 2-3 and 2-4

c) Type No. 3

d) Type No. 4

<https://standards.iteh.ai/catalog/standards/sist/849f9d13-d53e-4765-a550-f91ac979e567/iso-4510-2-1996>
 Figure 6

5.2 Push pullers

The dimensions of push pullers are given in figure 7 and table 2.

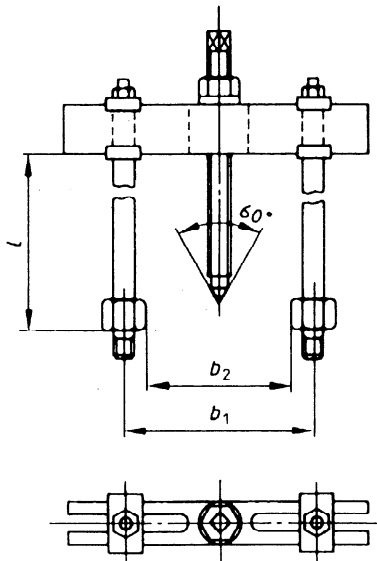

Figure 7

Table 2 — Push puller dimensions

Dimensions in millimetres

Type No.	Capacity kN	b_1	b_2	l
1	89	185 max. 56 min.	160 max. 31 min.	213
2	156	295 max. 90 min.	270 max. 65 min.	295
3	267	400 max. 160 min.	360 max. 120 min.	267

NOTE — l is based on the standard leg length.

5.3 Knife-edges of pulling attachments

The dimensions of the knife-edges of pulling attachments are given in figure 8 and table 3.

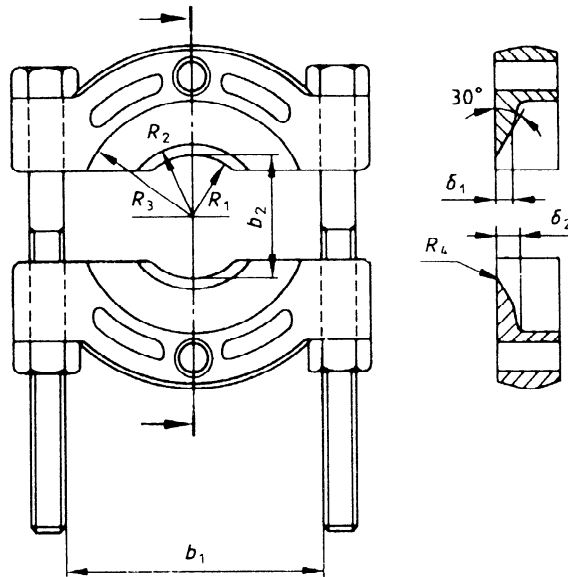

Figure 8
 iTeh STANDARD PREVIEW
 (standards.iteh.ai)

Table 3 — Pulling attachment dimensions

<https://standards.iteh.ai/catalog/standards/sist/849f9d13-d53e-4765-a550-f91ac979e567/iso-4510-2-1996> Dimensions in millimetres

Type No.	Capacity kN	b_1	b_2	δ_1	δ_2	R_1	R_2	R_3	R_4	Use width corresponding to:	
										push puller type No. ¹⁾	puller type No. ²⁾
1	35,5	62	50 max. 5 min.	2,9	4,3	15	20	25	0,2	—	1-2
2	80	110	110 max. 10 min.	4,5	8,7	25	32,8	48,5	0,2	1	1-3
3	133,5	152	135 max. 15 min.	5,5	13,3	35	44,5	73,5	0,2	2	1-3, 2-1
4	178	180	205 max. 15 min.	7,5	15	50	63	91	0,2	3	2-2, 2-3
5	178	260	340 max. 20 min.	9,8	15	85	102	121,5	0,2	3	2-3

1) See table 2.

2) See table 1.

5.4 Male thread of pulling adaptors

The male thread (see figure 4) of pulling adaptors is specified in table 4.

Table 4 — Pulling adaptor threads

Type No.	Thread
1	M12 × 1,25
2	M12 × 1,75
3	M14 × 1,5
4	M14 × 2
5	M16 × 1,5
6	M16 × 2
7	M18 × 1,5
8	M18 × 2,5
9	M20 × 1,5
10	M20 × 2,5

5.5 Outside diameters of step plate adaptors

The outside diameters of step plate adaptors are given in figure 9 and table 5.

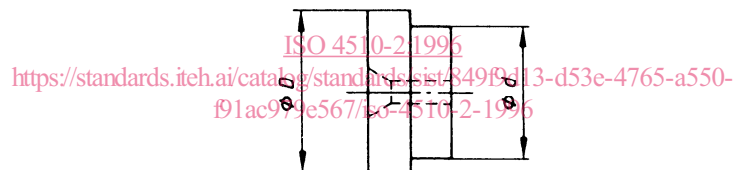

Figure 9

Table 5 — Step plate adaptor dimensions

Dimensions in millimetres

Type No.	<i>D</i>	<i>d</i>
1	25	15
2	30	20
3	35	25
4	40	30
5	50	35
6	60	45
7	70	55
8	80	60
9	90	70
10	100	80