Industrijska komunikacijska omrežja - Profili - 3-8. del: Funkcijska varnost procesnih vodil - Dodatne specifikacije za CPF 8 (IEC 61784-3-8:2010)

Industrial communication networks - Profiles - Part 3-8: Functional safety fieldbuses - Additional specifications for CPF 8 (IEC 61784-3-8:2010)

Industrielle Kommunikationsnetze - Profile - Teil 3-8: Funktional sichere Übertragung bei Feldbussen - Zusätzliche Festlegungen für die Kommunikationsprofilfamilie 8 (IEC 61784-3-8:2010)

(standards.iteh.ai)

Réseaux de communication industriels - Profils - Partie 3-8: Bus de terrain de sécurité fonctionnelle - Spécification supplémentaire pour CPF 8 (CEI 61784-3-8:2010)

Ta slovenski standard je istoveten z: EN 61784-3-8:2010

ICS:

25.040.40	Merjenje in krmiljenje industrijskih postopkov	Industrial process measurement and control
35.100.05	Večslojne uporabniške rešitve	Multilayer applications

SIST EN 61784-3-8:2010**en**

iTeh STANDARD PREVIEW
(standards.iteh.ai)

SIST EN 61784-3-8:2010

<https://standards.iteh.ai/catalog/standards/sist/c405b8ca-ef97-4e8f-998c-3b73c57a2a56/sist-en-61784-3-8-2010>

EUROPEAN STANDARD
NORME EUROPÉENNE
EUROPÄISCHE NORM

EN 61784-3-8

August 2010

ICS 25.040.40; 35.100.05

English version

**Industrial communication networks -
Profiles -
Part 3-8: Functional safety fieldbuses -
Additional specifications for CPF 8
(IEC 61784-3-8:2010)**

Réseaux de communication industriels -
Profils -
Partie 3-8: Bus de terrain de sécurité
fonctionnelle -
Spécification supplémentaire pour CPF 8
(CEI 61784-3-8:2010)

Industrielle Kommunikationsnetze -
Profile -
Teil 3-8: Funktional sichere Übertragung
bei Feldbussen -
Zusätzliche Festlegungen
für die Kommunikationsprofilfamilie 8
(IEC 61784-3-8:2010)

**ITeh STANDARD PREVIEW
(standards.iteh.ai)**

[SIST EN 61784-3-8:2010](https://standards.iteh.ai/catalog/standards/sist/c405b8ca-ef97-4e8f-998c-2010-07-01)

<https://standards.iteh.ai/catalog/standards/sist/c405b8ca-ef97-4e8f-998c-2010-07-01>

This European Standard was approved by CENELEC on 2010-07-01. CENELEC members are bound to comply with the CEN/CENELEC Internal Regulations which stipulate the conditions for giving this European Standard the status of a national standard without any alteration.

Up-to-date lists and bibliographical references concerning such national standards may be obtained on application to the Central Secretariat or to any CENELEC member.

This European Standard exists in three official versions (English, French, German). A version in any other language made by translation under the responsibility of a CENELEC member into its own language and notified to the Central Secretariat has the same status as the official versions.

CENELEC members are the national electrotechnical committees of Austria, Belgium, Bulgaria, Croatia, Cyprus, the Czech Republic, Denmark, Estonia, Finland, France, Germany, Greece, Hungary, Iceland, Ireland, Italy, Latvia, Lithuania, Luxembourg, Malta, the Netherlands, Norway, Poland, Portugal, Romania, Slovakia, Slovenia, Spain, Sweden, Switzerland and the United Kingdom.

CENELEC

European Committee for Electrotechnical Standardization
Comité Européen de Normalisation Electrotechnique
Europäisches Komitee für Elektrotechnische Normung

Management Centre: Avenue Marnix 17, B - 1000 Brussels

Foreword

The text of document 65C/591A/FDIS, future edition 1 of IEC 61784-3-8, prepared by SC 65C, Industrial networks, of IEC TC 65, Industrial-process measurement, control and automation, was submitted to the IEC-CENELEC parallel vote and was approved by CENELEC as EN 61784-3-8 on 2010-07-01.

Attention is drawn to the possibility that some of the elements of this document may be the subject of patent rights. CEN and CENELEC shall not be held responsible for identifying any or all such patent rights.

The following dates were fixed:

- latest date by which the EN has to be implemented at national level by publication of an identical national standard or by endorsement (dop) 2011-04-01
- latest date by which the national standards conflicting with the EN have to be withdrawn (dow) 2013-07-01

Annex ZA has been added by CENELEC.

Endorsement notice

The text of the International Standard IEC 61784-3-8:2010 was approved by CENELEC as a European Standard without any modification.

In the official version, for Bibliography, the following notes have to be added for the standards indicated:

IEC 61496 series	NOTE	Harmonized in EN 61496 series (partially modified).
IEC 61508-1:2010	NOTE	Harmonized as EN 61508-1:2010 (not modified).
IEC 61508-4:2010	NOTE	Harmonized as EN 61508-4:2010 (not modified).
IEC 61508-5:2010	NOTE	Harmonized as EN 61508-5:2010 (not modified).
IEC 61784-2	NOTE	Harmonized as EN 61784-2.
IEC 61784-5 series	NOTE	Harmonized in EN 61784-5 series (not modified).
IEC 61800-5-2	NOTE	Harmonized as EN 61800-5-2.
IEC 61918	NOTE	Harmonized as EN 61918.
ISO 10218-1	NOTE	Harmonized as EN ISO 10218-1.
ISO 12100-1	NOTE	Harmonized as EN ISO 12100-1.
ISO 13849-1	NOTE	Harmonized as EN ISO 13849-1.
ISO 13849-2	NOTE	Harmonized as EN ISO 13849-2.

Annex ZA (normative)

Normative references to international publications with their corresponding European publications

The following referenced documents are indispensable for the application of this document. For dated references, only the edition cited applies. For undated references, the latest edition of the referenced document (including any amendments) applies.

NOTE When an international publication has been modified by common modifications, indicated by (mod), the relevant EN/HD applies.

<u>Publication</u>	<u>Year</u>	<u>Title</u>	<u>EN/HD</u>	<u>Year</u>
IEC 60204-1	-	Safety of machinery - Electrical equipment of machines - Part 1: General requirements	EN 60204-1	-
IEC 61131-2	-	Programmable controllers - Part 2: Equipment requirements and tests	EN 61131-2	-
IEC 61158	Series	Industrial communication networks - Fieldbus specifications -	EN 61158	Series
IEC 61158-2	-	Industrial communication networks – Fieldbus specifications - Part 2: Physical layer specification and service definition	EN 61158-2	-
IEC 61158-3-18	-	Industrial communication networks - Fieldbus specifications - Part 3-18: Data-link layer service definition - Type 18 elements	EN 61158-3-18	-
IEC 61158-4-18	-	Industrial communication networks - Fieldbus specifications - Part 4-18: Data-link layer protocol specification - Type 18 elements	EN 61158-4-18	-
IEC 61158-5-18	-	Industrial communication networks - Fieldbus specifications - Part 5-18: Application layer service definition - Type 18 elements	EN 61158-5-18	-
IEC 61158-6-18	-	Industrial communication networks - Fieldbus specifications - Part 6-18: Application layer protocol specification - Type 18 elements	EN 61158-6-18	-
IEC 61326-3-1	-	Electrical equipment for measurement, control and laboratory use - EMC requirements - Part 3-1: Immunity requirements for safety- related systems and for equipment intended to perform safety-related functions (functional safety) - General industrial applications	EN 61326-3-1	-

<u>Publication</u>	<u>Year</u>	<u>Title</u>	<u>EN/HD</u>	<u>Year</u>
IEC 61326-3-2	-	Electrical equipment for measurement, control and laboratory use - EMC requirements - Part 3-2: Immunity requirements for safety-related systems and for equipment intended to perform safety-related functions (functional safety) - Industrial applications with specified electromagnetic environment	EN 61326-3-2	-
IEC 61508	Series	Functional safety of electrical/electronic/programmable electronic safety-related systems	EN 61508	Series
IEC 61511	Series	Functional safety - Safety instrumented systems for the process industry sector	EN 61511	Series
IEC 61784-1	-	Industrial communication networks - Profiles - Part 1: Fieldbus profiles	EN 61784-1	-
IEC 61784-3	2010	Industrial communication networks - Profiles - Part 3: Functional safety fieldbuses - General rules and profile definitions	EN 61784-3	2010
IEC 62061	-	Safety of machinery - Functional safety of safety-related electrical, electronic and programmable electronic control systems	EN 62061	-

iTeh STANDARD PREVIEW (standards.iteh.ai)

[SIST EN 61784-3-8:2010](#)

<https://standards.iteh.ai/catalog/standards/sist/c405b8ca-ef97-4e8f-998c-3b73c57a2a56/sist-en-61784-3-8-2010>



IEC 61784-3-8

Edition 1.0 2010-06

INTERNATIONAL STANDARD



**Industrial communication networks – Profiles –
Part 3-8: Functional safety fieldbuses – Additional specifications for CPF 8**

STANDARD PREVIEW
(standards.iteh.ai)

SIST EN 61784-3-8:2010
<https://standards.iteh.ai/catalog/standards/sist/c405b8ca-ef97-4e8f-998c-3b73c57a2a56/sist-en-61784-3-8-2010>

INTERNATIONAL
ELECTROTECHNICAL
COMMISSION

PRICE CODE



ICS 25.040.40; 35.100.05

ISBN 978-2-88910-980-7

CONTENTS

FOREWORD.....	5
INTRODUCTION.....	7
1 Scope.....	10
2 Normative references.....	10
3 Terms, definitions, symbols, abbreviated terms and conventions.....	11
3.1 Terms and definitions.....	11
3.1.1 Common terms and definitions.....	11
3.1.2 CPF 8: Additional terms and definitions.....	16
3.2 Symbols and abbreviated terms.....	16
3.2.1 Common symbols and abbreviated terms.....	16
3.2.2 CPF 8: Additional symbols and abbreviated terms.....	17
3.3 Conventions.....	17
4 Overview of FSCP 8/1 (CC-Link Safety™).....	17
5 General.....	18
5.1 External documents providing specifications for the profile.....	18
5.2 Safety functional requirements.....	18
5.3 Safety measures.....	18
5.3.1 General.....	18
5.3.2 Sequence number.....	19
5.3.3 Time expectation.....	19
5.3.4 Connection authentication.....	20
5.3.5 Feedback message.....	20
5.3.6 Different data integrity assurance system.....	20
5.4 Safety communication layer structure.....	20
5.5 Relationships with FAL (and DLL, PhL).....	21
5.5.1 Overview.....	21
5.5.2 Data types.....	21
6 Safety communication layer services.....	21
6.1 General.....	21
6.2 SASEs.....	21
6.2.1 M1 safety device manager class specification.....	21
6.2.2 S1 safety device manager class specification.....	22
6.3 SARs.....	22
6.3.1 M1 safety connection manager class.....	22
6.3.2 S1 safety connection manager class.....	22
6.4 Process data SAR ASEs.....	23
6.4.1 M1 safety cyclic transmission class specification.....	23
6.4.2 S1 safety cyclic transmission class specification.....	23
7 Safety communication layer protocol.....	24
7.1 Safety PDU format.....	24
7.1.1 General.....	24
7.1.2 Abstract syntax.....	24
7.1.3 Transfer syntax.....	26
7.2 State description.....	30
7.2.1 Overview.....	30
7.2.2 Idle.....	31

7.2.3	FAL running.....	31
7.2.4	SCL running	32
7.2.5	Fail safe	32
7.2.6	Safety data transmission and processing.....	32
7.2.7	Forced termination	34
8	Safety communication layer management.....	34
8.1	General.....	34
8.2	Connection establishment and confirmation processing.....	35
8.3	Safety slave verification	35
8.3.1	General	35
8.3.2	Safety slave information verification process	35
8.3.3	Safety slave parameter transmission	35
9	System requirements.....	36
9.1	Indicators and switches	36
9.1.1	Switches.....	36
9.1.2	Indicators	36
9.2	Installation guidelines.....	37
9.3	Safety function response time	37
9.3.1	General	37
9.3.2	Time calculation	37
9.4	Duration of demands	39
9.5	Constraints for calculation of system characteristics	39
9.5.1	System characteristics.....	39
9.5.2	Residual error rate (Λ).....	39
9.6	Maintenance.....	40
9.7	Safety manual	40
10	Assessment.....	41
	Annex A (informative) Additional information for functional safety communication profiles of CPF 8.....	42
	A.1 Hash function calculation.....	42
	A.2	42
	Annex B (informative) Information for assessment of the functional safety communication profiles of CPF 8	43
	Bibliography.....	44
	Table 1 – Selection of the various measures for possible errors.....	19
	Table 2 – M1 safety device manager attribute format.....	24
	Table 3 – S1 safety device manager attribute format	24
	Table 4 – M1 safety connection manager attribute format	24
	Table 5 – S1 safety connection manager attribute format.....	25
	Table 6 – M1 safety cyclic transmission attribute format	25
	Table 7 – S1 safety cyclic transmission attribute format	26
	Table 8 – M1 safety device manager attribute encoding.....	26
	Table 9 – S1 safety device manager attribute encoding	27
	Table 10 – M1 safety connection manager attribute encoding	27
	Table 11 – S1 safety connection manager attribute encoding.....	27

Table 12 – M1 safety cyclic transmission attribute encoding	28
Table 13 – S1 safety cyclic transmission attribute encoding	29
Table 14 – Safety master monitor timer operation	33
Table 15 – Safety slave monitor timer operation	33
Table 16 – Safety data monitor timer operation	33
Table 17 – Details of connection establishment and confirmation processing	35
Table 18 – Details of slave information verification processing	35
Table 19 – Details of safety slave parameter transmission processing	36
Table 20 – Monitor LEDs	36
Table 21 – Safety function response time calculation	38
Table 22 – Safety function response time definition of terms	38
Table 23 – Number of occupied slots and safety data	39
Table 24 – Residual error rate Λ (occupied slots = 1)	40
Table 25 – Residual error rate Λ (occupied slots = 2)	40
Figure 1 – Relationships of IEC 61784-3 with other standards (machinery)	7
Figure 2 – Relationships of IEC 61784-3 with other standards (process)	8
Figure 3 – Relationship between SCL and the other layers of IEC 61158 Type 18	21
Figure 4 – State diagram	31

SIST EN 61784-3-8:2010

<https://standards.iteh.ai/catalog/standards/sist/c405b8ca-ef97-4e8f-998c-3b73c57a2a56/sist-en-61784-3-8-2010>

INTERNATIONAL ELECTROTECHNICAL COMMISSION

**INDUSTRIAL COMMUNICATION NETWORKS –
PROFILES –****Part 3-8: Functional safety fieldbuses –
Additional specifications for CPF 8**

FOREWORD

- 1) The International Electrotechnical Commission (IEC) is a worldwide organization for standardization comprising all national electrotechnical committees (IEC National Committees). The object of IEC is to promote international co-operation on all questions concerning standardization in the electrical and electronic fields. To this end and in addition to other activities, IEC publishes International Standards, Technical Specifications, Technical Reports, Publicly Available Specifications (PAS) and Guides (hereafter referred to as "IEC Publication(s)"). Their preparation is entrusted to technical committees; any IEC National Committee interested in the subject dealt with may participate in this preparatory work. International, governmental and non-governmental organizations liaising with the IEC also participate in this preparation. IEC collaborates closely with the International Organization for Standardization (ISO) in accordance with conditions determined by agreement between the two organizations.
- 2) The formal decisions or agreements of IEC on technical matters express, as nearly as possible, an international consensus of opinion on the relevant subjects since each technical committee has representation from all interested IEC National Committees.
- 3) IEC Publications have the form of recommendations for international use and are accepted by IEC National Committees in that sense. While all reasonable efforts are made to ensure that the technical content of IEC Publications is accurate, IEC cannot be held responsible for the way in which they are used or for any misinterpretation by any end user.
- 4) In order to promote international uniformity, IEC National Committees undertake to apply IEC Publications transparently to the maximum extent possible in their national and regional publications. Any divergence between any IEC Publication and the corresponding national or regional publication shall be clearly indicated in the latter.
- 5) IEC itself does not provide any attestation of conformity. Independent certification bodies provide conformity assessment services and, in some areas, access to IEC marks of conformity. IEC is not responsible for any services carried out by independent certification bodies.
- 6) All users should ensure that they have the latest edition of this publication.
- 7) No liability shall attach to IEC or its directors, employees, servants or agents including individual experts and members of its technical committees and IEC National Committees for any personal injury, property damage or other damage of any nature whatsoever, whether direct or indirect, or for costs (including legal fees) and expenses arising out of the publication, use of, or reliance upon, this IEC Publication or any other IEC Publications.
- 8) Attention is drawn to the Normative references cited in this publication. Use of the referenced publications is indispensable for the correct application of this publication.

International Standard IEC 61784-3-8 has been prepared by subcommittee 65C: Industrial networks, of IEC technical committee 65: Industrial process measurement, control and automation.

The text of this standard is based on the following documents:

FDIS	Report on voting
65C/591A/FDIS	65C/603/RVD

Full information on the voting for the approval of this standard can be found in the report on voting indicated in the above table.

This publication has been drafted in accordance with the ISO/IEC Directives, Part 2.

A list of all parts of the IEC 61784-3 series, published under the general title *Industrial communication networks – Profiles – Functional safety fieldbuses*, can be found on the IEC website.

The committee has decided that the contents of this publication will remain unchanged until the stability date indicated on the IEC web site under "http://webstore.iec.ch" in the data related to the specific publication. At this date, the publication will be

- reconfirmed,
- withdrawn,
- replaced by a revised edition, or
- amended.

IMPORTANT – The 'colour inside' logo on the cover page of this publication indicates that it contains colours which are considered to be useful for the correct understanding of its contents. Users should therefore print this document using a colour printer.

iTeh STANDARD PREVIEW (standards.iteh.ai)

[SIST EN 61784-3-8:2010](https://standards.iteh.ai/catalog/standards/sist/c405b8ca-ef97-4e8f-998c-3b73c57a2a56/sist-en-61784-3-8-2010)

<https://standards.iteh.ai/catalog/standards/sist/c405b8ca-ef97-4e8f-998c-3b73c57a2a56/sist-en-61784-3-8-2010>

INTRODUCTION

The IEC 61158 fieldbus standard together with its companion standards IEC 61784-1 and IEC 61784-2 defines a set of communication protocols that enable distributed control of automation applications. Fieldbus technology is now considered well accepted and well proven. Thus many fieldbus enhancements are emerging, addressing not yet standardized areas such as real time, safety-related and security-related applications.

This standard explains the relevant principles for functional safety communications with reference to IEC 61508 series and specifies several safety communication layers (profiles and corresponding protocols) based on the communication profiles and protocol layers of IEC 61784-1, IEC 61784-2 and the IEC 61158 series. It does not cover electrical safety and intrinsic safety aspects.

Figure 1 shows the relationships between this standard and relevant safety and fieldbus standards in a machinery environment.

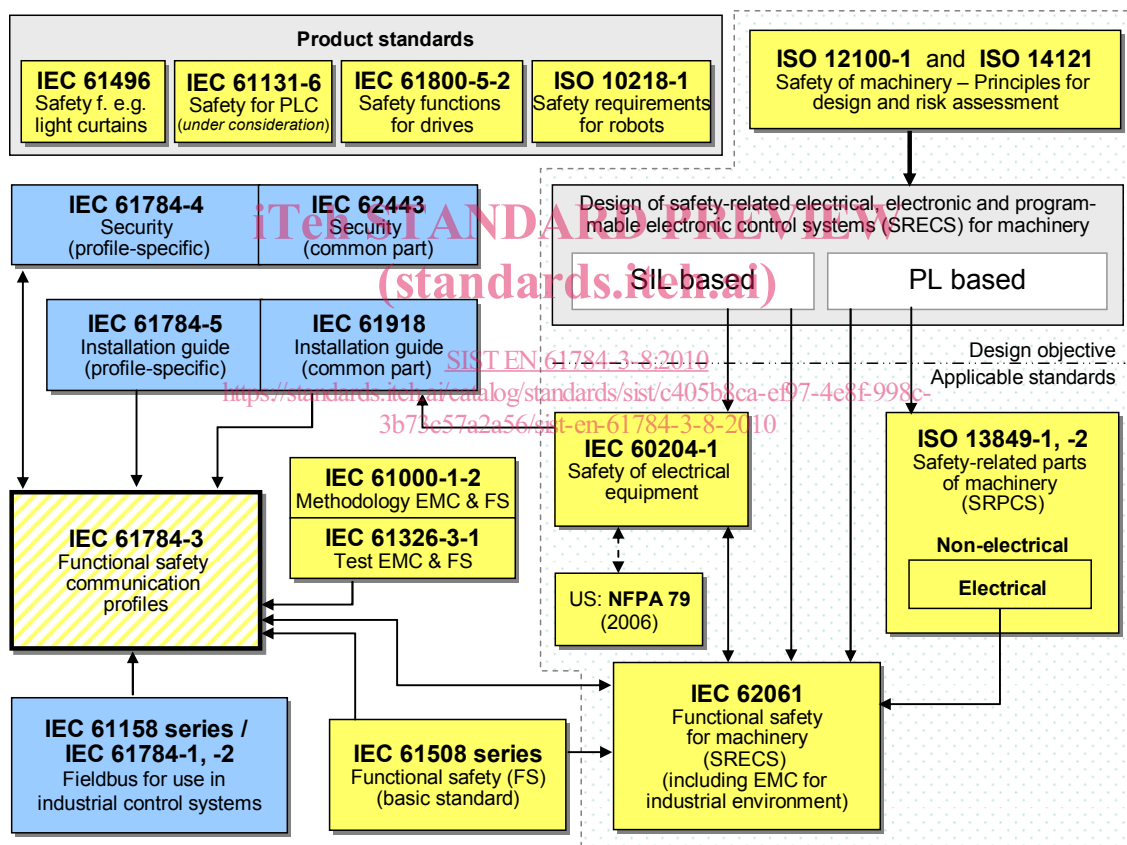

NOTE Subclauses 6.7.6.4 (high complexity) and 6.7.8.1.6 (low complexity) of IEC 62061 specify the relationship between PL (Category) and SIL.

Figure 1 – Relationships of IEC 61784-3 with other standards (machinery)

Figure 2 shows the relationships between this standard and relevant safety and fieldbus standards in a process environment.

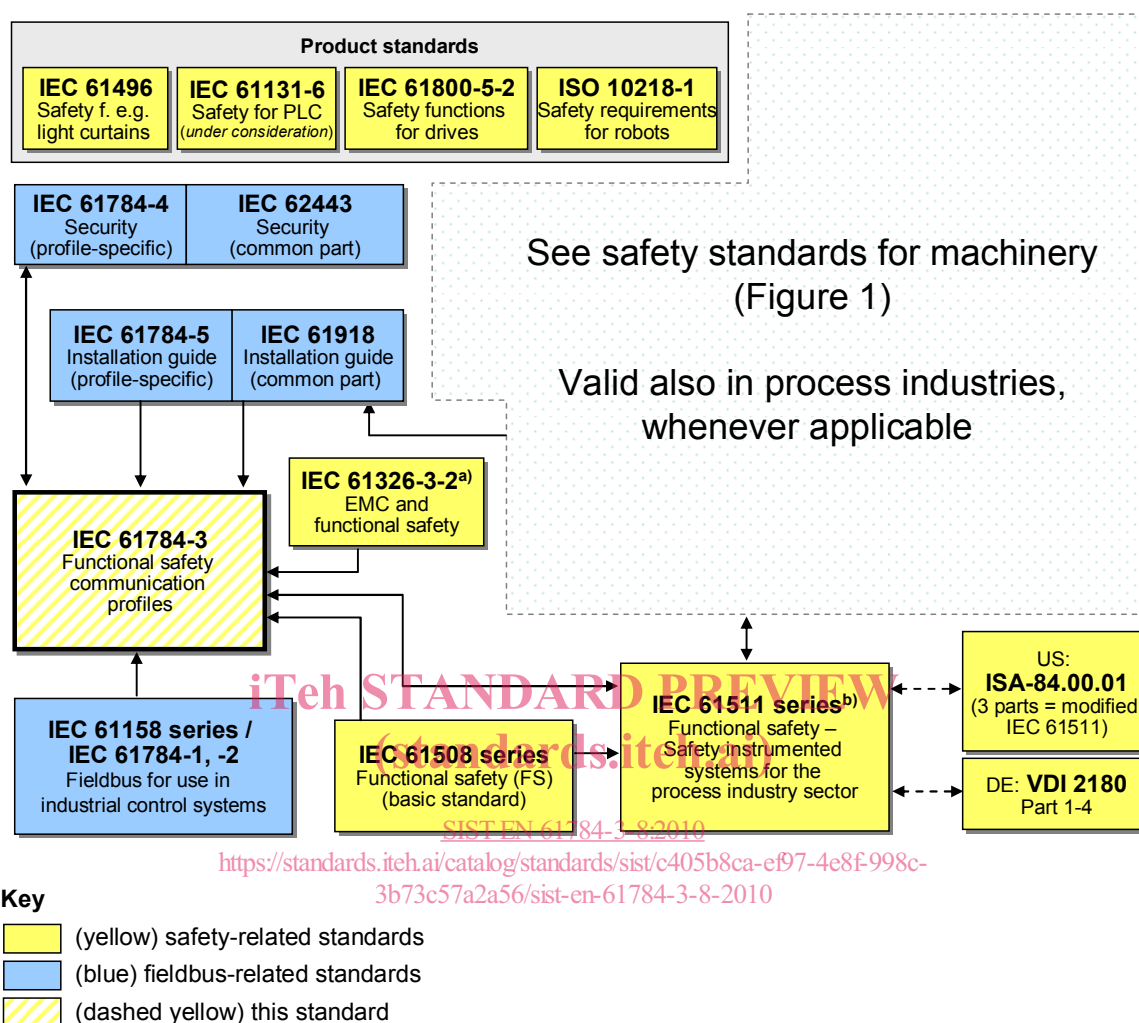

^a For specified electromagnetic environments; otherwise IEC 61326-3-1.

^b EN ratified.

Figure 2 – Relationships of IEC 61784-3 with other standards (process)

Safety communication layers which are implemented as parts of safety-related systems according to IEC 61508 series provide the necessary confidence in the transportation of messages (information) between two or more participants on a fieldbus in a safety-related system, or sufficient confidence of safe behaviour in the event of fieldbus errors or failures.

Safety communication layers specified in this standard do this in such a way that a fieldbus can be used for applications requiring functional safety up to the Safety Integrity Level (SIL) specified by its corresponding functional safety communication profile.

The resulting SIL claim of a system depends on the implementation of the selected functional safety communication profile within this system – implementation of a functional safety communication profile in a standard device is not sufficient to qualify it as a safety device.

This standard describes:

- basic principles for implementing the requirements of IEC 61508 series for safety-related data communications, including possible transmission faults, remedial measures and considerations affecting data integrity;
- individual description of functional safety profiles for several communication profile families in IEC 61784-1 and IEC 61784-2;
- safety layer extensions to the communication service and protocols sections of the IEC 61158 series.

iTeh STANDARD PREVIEW **(standards.iteh.ai)**

SIST EN 61784-3-8:2010

<https://standards.iteh.ai/catalog/standards/sist/c405b8ca-ef97-4e8f-998c-3b73c57a2a56/sist-en-61784-3-8-2010>