

TECHNICAL REPORT



Dynamic modules – **STANDARD PREVIEW**
Part 6-10: Design guide – Intermediate controller for multiple dynamic module
systems
(standards.iteh.ai)

[IEC TR 62343-6-10:2017](https://standards.iteh.ai/catalog/standards/sist/a06966cb-61ce-41fd-bd06-e6f2ef5c2c14/iec-tr-62343-6-10-2017)

<https://standards.iteh.ai/catalog/standards/sist/a06966cb-61ce-41fd-bd06-e6f2ef5c2c14/iec-tr-62343-6-10-2017>



THIS PUBLICATION IS COPYRIGHT PROTECTED

Copyright © 2017 IEC, Geneva, Switzerland

All rights reserved. Unless otherwise specified, no part of this publication may be reproduced or utilized in any form or by any means, electronic or mechanical, including photocopying and microfilm, without permission in writing from either IEC or IEC's member National Committee in the country of the requester. If you have any questions about IEC copyright or have an enquiry about obtaining additional rights to this publication, please contact the address below or your local IEC member National Committee for further information.

IEC Central Office
3, rue de Varembe
CH-1211 Geneva 20
Switzerland

Tel.: +41 22 919 02 11
Fax: +41 22 919 03 00
info@iec.ch
www.iec.ch

About the IEC

The International Electrotechnical Commission (IEC) is the leading global organization that prepares and publishes International Standards for all electrical, electronic and related technologies.

About IEC publications

The technical content of IEC publications is kept under constant review by the IEC. Please make sure that you have the latest edition, a corrigenda or an amendment might have been published.

IEC Catalogue - webstore.iec.ch/catalogue

The stand-alone application for consulting the entire bibliographical information on IEC International Standards, Technical Specifications, Technical Reports and other documents. Available for PC, Mac OS, Android Tablets and iPad.

IEC publications search - www.iec.ch/searchpub

The advanced search enables to find IEC publications by a variety of criteria (reference number, text, technical committee,...). It also gives information on projects, replaced and withdrawn publications.

IEC Just Published - webstore.iec.ch/justpublished

Stay up to date on all new IEC publications. Just Published details all new publications released. Available online and also once a month by email.

Electropedia - www.electropedia.org

The world's leading online dictionary of electronic and electrical terms containing 20 000 terms and definitions in English and French, with equivalent terms in 16 additional languages. Also known as the International Electrotechnical Vocabulary (IEV) online.

IEC Glossary - std.iec.ch/glossary

65 000 electrotechnical terminology entries in English and French extracted from the Terms and Definitions clause of IEC publications issued since 2002. Some entries have been collected from earlier publications of IEC TC 37, 77, 86 and CISPR.

IEC Customer Service Centre - webstore.iec.ch/csc

If you wish to give us your feedback on this publication or need further assistance, please contact the Customer Service Centre: csc@iec.ch.

IEC STANDARD PREVIEW
(standards.iteh.ai)
IEC TR 62343-10:2017
https://standards.iteh.ai/catalog/standards/iec/62343-10-2017
e6f2ef5c2c14/iec-tr-62343-10-2017

TECHNICAL REPORT



Dynamic modules – Part 6-10: Design guide – Intermediate controller for multiple dynamic module systems

STANDARD PREVIEW
(standards.iteh.ai)

[IEC TR 62343-6-10:2017](https://standards.iteh.ai/catalog/standards/sist/a06966cb-61ce-41fd-bd06-e6f2ef5c2c14/iec-tr-62343-6-10-2017)

<https://standards.iteh.ai/catalog/standards/sist/a06966cb-61ce-41fd-bd06-e6f2ef5c2c14/iec-tr-62343-6-10-2017>

INTERNATIONAL
ELECTROTECHNICAL
COMMISSION

ICS 33.180.01, 33.180.99

ISBN 978-2-8322-4127-1

Warning! Make sure that you obtained this publication from an authorized distributor.

CONTENTS

FOREWORD.....	3
INTRODUCTION.....	5
1 Scope.....	6
2 Normative references	6
3 Terms, definitions and abbreviated terms	6
3.1 Terms and definitions.....	6
3.2 Abbreviated terms.....	6
4 Background of the software defined networking and its control plane for optical nodes	7
5 Research activities on high-performance node systems where intermediate controller plays key role.....	7
5.1 Photonic network with OpenFlow® controller	7
5.2 Dynamic optical path network with a network controller.....	7
5.3 Control interface of the Photonic Layer-2	8
6 Intermediate controller for multiple dynamic module systems.....	8
6.1 Description of the controller	8
6.1.1 Controller of multiple dynamic modules for a network node.....	8
6.1.2 Structure of the intermediate controller.....	9
6.2 Functions.....	10
6.3 Shared information between the control interface and the network control plane	11
7 Example of multi-degree ROADM systems.....	12
8 Conclusion	14
Bibliography.....	15
Figure 1 – Conceptual block of the control interface for multiple dynamic modules and network devices.....	8
Figure 2 – Basic block of the control interface for multiple dynamic modules.....	9
Figure 3 – Difference between connection information and configuration information	10
Figure 4 – Function coverage of the intermediate controller	11
Figure 5 – Example of a multiple dynamic module system.....	12
Figure 6 – Example of 4-degree ROADM node architecture	13
Figure 7 – 3-degree ROADM node with colourless, non-directional add/drop ports.....	13
Figure 8 – Compact PLC-based transponder aggregator for colourless and directionless ROADM.....	14
Table 1 – Shared information in the intermediate controller.....	12

INTERNATIONAL ELECTROTECHNICAL COMMISSION

DYNAMIC MODULES –

**Part 6-10: Design guide – Intermediate controller
for multiple dynamic module systems**

FOREWORD

- 1) The International Electrotechnical Commission (IEC) is a worldwide organization for standardization comprising all national electrotechnical committees (IEC National Committees). The object of IEC is to promote international co-operation on all questions concerning standardization in the electrical and electronic fields. To this end and in addition to other activities, IEC publishes International Standards, Technical Specifications, Technical Reports, Publicly Available Specifications (PAS) and Guides (hereafter referred to as "IEC Publication(s)"). Their preparation is entrusted to technical committees; any IEC National Committee interested in the subject dealt with may participate in this preparatory work. International, governmental and non-governmental organizations liaising with the IEC also participate in this preparation. IEC collaborates closely with the International Organization for Standardization (ISO) in accordance with conditions determined by agreement between the two organizations.
- 2) The formal decisions or agreements of IEC on technical matters express, as nearly as possible, an international consensus of opinion on the relevant subjects since each technical committee has representation from all interested IEC National Committees.
- 3) IEC Publications have the form of recommendations for international use and are accepted by IEC National Committees in that sense. While all reasonable efforts are made to ensure that the technical content of IEC Publications is accurate, IEC cannot be held responsible for the way in which they are used or for any misinterpretation by any end user.
- 4) In order to promote international uniformity, IEC National Committees undertake to apply IEC Publications transparently to the maximum extent possible in their national and regional publications. Any divergence between any IEC Publication and the corresponding national or regional publication shall be clearly indicated in the latter.
<https://standards.iteh.ai/catalog/standards/sist/a06966cb-61ce-41fd-bd06->
- 5) IEC itself does not provide any attestation of conformity. Independent certification bodies provide conformity assessment services and, in some areas, access to IEC marks of conformity. IEC is not responsible for any services carried out by independent certification bodies.
- 6) All users should ensure that they have the latest edition of this publication.
- 7) No liability shall attach to IEC or its directors, employees, servants or agents including individual experts and members of its technical committees and IEC National Committees for any personal injury, property damage or other damage of any nature whatsoever, whether direct or indirect, or for costs (including legal fees) and expenses arising out of the publication, use of, or reliance upon, this IEC Publication or any other IEC Publications.
- 8) Attention is drawn to the Normative references cited in this publication. Use of the referenced publications is indispensable for the correct application of this publication.
- 9) Attention is drawn to the possibility that some of the elements of this IEC Publication may be the subject of patent rights. IEC shall not be held responsible for identifying any or all such patent rights.

The main task of IEC technical committees is to prepare International Standards. However, a technical committee may propose the publication of a technical report when it has collected data of a different kind from that which is normally published as an International Standard, for example "state of the art".

IEC TR 62343-6-10, which is a technical report, has been prepared by subcommittee 86C: Fibre optic systems and active devices, of IEC technical committee TC 86: Fibre optics.

The text of this technical report is based on the following documents:

Enquiry draft	Report on voting
86C/1381/DTR	86C/1422/RVC

Full information on the voting for the approval of this technical report can be found in the report on voting indicated in the above table.

This document has been drafted in accordance with the ISO/IEC Directives, Part 2.

A list of all parts in the IEC 62343 series, published under the general title *Dynamic modules*, can be found on the IEC website.

The committee has decided that the contents of this document will remain unchanged until the stability date indicated on the IEC website under "<http://webstore.iec.ch>" in the data related to the specific document. At this date, the document will be

- reconfirmed,
- withdrawn,
- replaced by a revised edition, or
- amended.

A bilingual version of this publication may be issued at a later date.

IMPORTANT – The 'colour inside' logo on the cover page of this publication indicates that it contains colours which are considered to be useful for the correct understanding of its contents. Users should therefore print this document using a colour printer.

[IEC TR 62343-6-10:2017](https://standards.iteh.ai/catalog/standards/sist/a06966cb-61ce-41fd-bd06-e6f2ef5c2c14/iec-tr-62343-6-10-2017)

<https://standards.iteh.ai/catalog/standards/sist/a06966cb-61ce-41fd-bd06-e6f2ef5c2c14/iec-tr-62343-6-10-2017>

INTRODUCTION

Software defined networking (SDN) technology is widely recognized as a promising solution for flexible and efficient provisioning of networks by virtualizing their infrastructures, which results in cost-effective realization of high capacity, low energy consumption and even low latency. SDN technology will remain highly influential over global industries, societies, and the environment for many years to come.

Optical fibre communication technology has offered sufficient transport capacity with a fixed physical topology. However, recent technological progress in optical networking enables physical reconfiguration of optical paths by controlling multiple dynamic modules such as wavelength division multiplexing (WDM) devices and switching devices. Here, the key is to have an intermediate controller that controls and maintains the multiple dynamic modules in an integrated fashion, according to the upper layer controller of the SDN.

In order to realize such a reconfigurable and/or dynamically switchable optical network infrastructures at a hardware level in a cost-effective, reliable, scalable and low-carbon manner, it is important to initiate, in a timely manner and to a wide extent, conceptual and technical discussions, particularly on the intermediate controller for future standardization.

It is very important for industries to identify requirements for network architecture and devices/components in a timely manner, and to improve the technology development and investment efficiencies.

The objective of this part of IEC 62343 is to contribute to the standardization of basic requirements of the dynamic optical path networks using the intermediate controller.

STANDARD PREVIEW
(standards.iteh.ai)

[IEC TR 62343-6-10:2017](https://standards.iteh.ai/catalog/standards/sist/a06966cb-61ce-41fd-bd06-e6f2ef5c2c14/iec-tr-62343-6-10-2017)
<https://standards.iteh.ai/catalog/standards/sist/a06966cb-61ce-41fd-bd06-e6f2ef5c2c14/iec-tr-62343-6-10-2017>

DYNAMIC MODULES –

Part 6-10: Design guide – Intermediate controller for multiple dynamic module systems

1 Scope

This part of IEC 62343, which is a Technical Report, discusses the rationale, conceptual definition, and minimum list of functions for an intermediate controller that delivers a dynamic control signal to multiple dynamic modules. These modules are included in an optical-switch-based network node, according to the upper layer controller of software-defined optical networking.

2 Normative references

There are no normative references in this document.

3 Terms, definitions and abbreviated terms

3.1 Terms and definitions

No terms and definitions are listed in this document.

ISO and IEC maintain terminological databases for use in standardization at the following addresses:

- IEC Electropedia: available at <http://www.electropedia.org/>
- ISO Online browsing platform: available at <http://www.iso.org/obp>

3.2 Abbreviated terms

AWG	arrayed waveguide grating
C/D/C-ROADM	colourless/directionless/contentionless reconfigurable optical add-drop multiplexing
I/F	interface
IP	internet protocol
mI/F	module side interface
MCOS	multicast optical switch
OCM	optical channel monitor
ODU	optical data unit
OXC	optical cross connect
PLC	planar lightwave circuit
ROADM	reconfigurable optical add-drop multiplexing
Rx	receiver
SDN	software defined networking
TPA	transponder aggregator
Tx	transmitter
Tx/Rx	transceiver

WDM	wavelength division multiplexing
WSS	wavelength selective switch
WXC	wavelength cross connect

4 Background of the software defined networking and its control plane for optical nodes

Optical networks are evolving from static link services to flexible link services to provide future dynamic transport services. Software defined networking (SDN) is one of the network architectures that enable flexible and dynamic network control. The basic idea of SDN is to separate the control plane from the data plane, allowing consolidation of hardware infrastructure to save the overhead associated with per-service deployment of a closed set of resources such as computation, storage, and network. For optically switched networks such as colourless/directionless/contentionless reconfigurable optical add-drop multiplexing (C/D/C-ROADM) based mesh networks to be dynamically controlled through SDN, the control scheme should be designed to be as simple as possible, as they associate with complex configurations of multiple dynamic modules. In particular, common control interface is a key for realizing the control plane for such an optically switched node; thus, these interfaces should be properly defined from not only the software, but also the hardware aspect. Such an interface enables quick network building without hardware restrictions.

5 Research activities on high-performance node systems where intermediate controller plays key role

5.1 Photonic network with OpenFlow[®] controller

There are several kinds of high-performance node systems for recent high-speed communication systems, such as the internet protocol (IP) router in the field of data communication and the reconfigurable optical add-drop multiplexing (ROADM) system in transport systems. A high-performance node system itself is supported on an agile control basis. OpenFlow[®] is the first standard communication interface defined between the controlling and forwarding plane of an SDN architecture. The OpenFlow[®] controller is a well-organized network control method that enables the realization of flexible network control. The OpenFlow[®] controller, which handles the OpenFlow[®] protocol, was initiated by the Open Networking Foundation that grew out of work at Stanford University. Several vendors are already supporting OpenFlow[®] to be featured in multi-vendor interoperability, scalability and support of diverse environments. As a result, network users can make an independent control environment from network configurations. The technical documents are already available for practical use [1]².

5.2 Dynamic optical path network with a network controller

Dynamic optical path switching systems can provide an end-to-end connection in a network with huge-capacity links. In a network configuration having optical switches mutually connected in a mesh configuration in a transport network, the optical link services are dynamically provisioned in an end-to-end manner. In this case, energy consumption would be much smaller compared to high-end router chains. The National Institute of Advanced Industrial Science and Technology (AIST) proposes to call such networks dynamic optical path networks [2]. Of course, this system requires an additional control plane network; therefore, the necessary communication capacity for the control plane network is prepared. In this network, dynamic modules in systems can be controlled by a single network controller having a joint control interface to the control plane. This single link on the control plane needs to be well-organized.

¹ OpenFlow[®] is the trademark of a product supplied by Open Networking Foundation. This information is given for the convenience of users of this document and does not constitute an endorsement by IEC of the product named. Equivalent products may be used if they can be shown to lead to the same results.

² Numbers in square brackets refer to the Bibliography

5.3 Control interface of the Photonic Layer-2

Future photonic nodes that incorporate technologies such as digital coherent optical transceivers and flexible-grid WDM can create optical paths with arbitrary bandwidths over a large dynamic range of around 30 dB, ranging from 1 Gbit/s to 1 Tbit/s. This can enable the flexible and efficient utilization of fibre capacity in the smart photonic cloud. For efficiently controlling the hypothetical network and synthetic of each photonic node, common interface of the node should be prepared. The Task Force Group of the Photonic Internet Forum is already promoting flexible control schemes for optical network nodes [3]. This forum tries to increase the number of the hypothetical network layer and extend the dynamic range of slice capacity, owing to the flexible spectral arrangement and sub-wavelength path.

6 Intermediate controller for multiple dynamic module systems

6.1 Description of the controller

6.1.1 Controller of multiple dynamic modules for a network node

For configuring a single network node as a high-performance node system, the control part should be a single interface to the network control plane. The control interface is a network controller that unifies multiple dynamic modules with various hardware/software components to make it behave as a single network node. This concept helps in building up the optical network system in a way that simplifies the entire hardware configuration. Figure 1 shows a conceptual block of the control interface for multiple dynamic modules and network devices. From a network configuration point of view, three layers (the application layer, control layer, and infrastructure layer) work as a coordinated network. A large amount of communication equipment, such as optical transport systems, is distributed in the infrastructure layer, and system configuration in the infrastructure layer has an impact on the adjacent layer. The intermediate controller has the role of wrapping up several network devices and dynamic modules in the system. Thus, the intermediate controller provides a simplified communication environment to the system, and it can be a wrap-up control port of the high-performance node system.

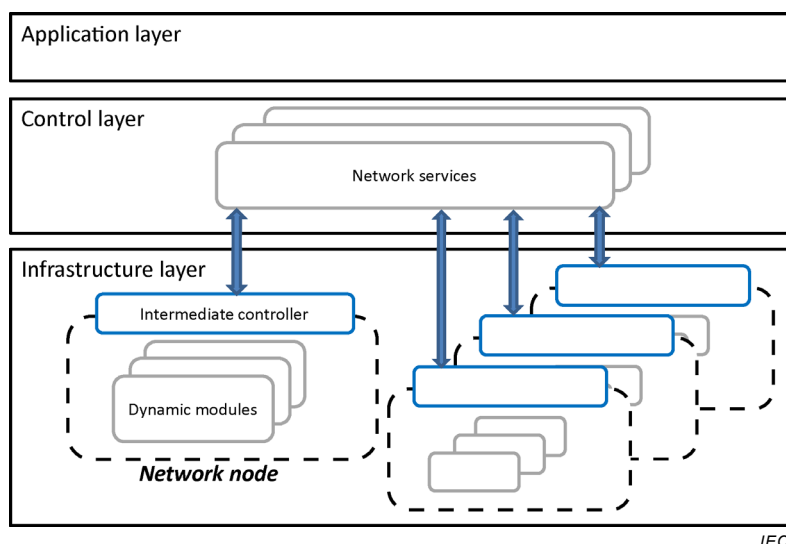

Figure 1 – Conceptual block of the control interface for multiple dynamic modules and network devices

Optical communication systems, such as high-performance node systems, employ a variety of modules and components. An intermediate controller is required in the system for controlling the entire set of components. The controller should work as a single control interface to convey control signals to multiple dynamic modules, such as OXC, WSS, and WXC, because a single resource management system sends out the network configuration order to the

system. Therefore, the system should have a proper reception block of the control signal of the dynamic modules, which is the role of the intermediate controller. Typically, the controller has several functions in a system. For a high-performance node system in a transport system, the intermediate controllers control the following dynamic modules in the system:

- OXC (optical cross connect);
- WSS (wavelength selective switch);
- WXC (wavelength cross connect);
- MCOS (multicast optical switch);
- OCM (optical channel monitor).

These modules also have some specific interfaces, and their specifications are available in IEC standard documents.

6.1.2 Structure of the intermediate controller

The intermediate controller is located between multiple dynamic modules and specific network services in the control layer for multiple dynamic modules and network devices. Figure 2 shows the structure of the control interface. It consists of a control side interface (I/F) for the network control plane, module side I/Fs (ml/Fs) for various dynamic optical modules, and a programmable block that has reconfigurable logic functions as a hardware abstraction layer. The control side I/F can be a single interface to the network control plane. The logical and physical definitions of I/Fs are consistent with the on-going standardization of the network control plane for SDN and dynamic optical path network. This control interface provides wrap-up functions for multiple dynamic module systems, and several types of dynamic modules of multi-layer and multi-level systems are controlled uniformly from the network control plane.

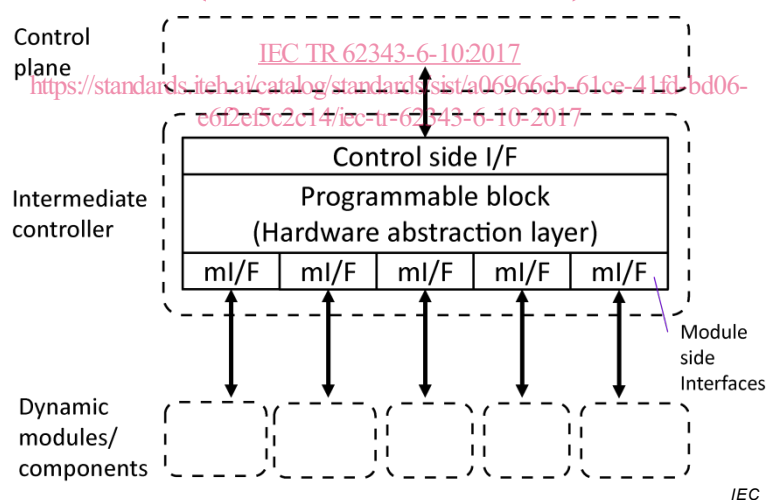

Figure 2 – Basic block of the control interface for multiple dynamic modules

The control side interface is a gateway port to the network control plane, and it works as a command sender/receiver to the control plane. Several physical layers can be set to this port such as Ether port, a network interface card, and a transceiver for the control plane.

The programmable block is located between the control-side I/F and the module side I/F. It is also known as a hardware abstraction layer. It interprets control commands from the network control plane to the dynamic optical modules, and the block refers to the information shared with the network control plane and the dynamic optical modules. It has a memory and look-up table as programmed resources. Monitored information of the modules is also available for sharing through the interface to the control plane. This programmable block provides the function of wrapping multiple optical modules using hardware resource information. This block needs to store the following information: