



SLOVENSKI STANDARD
SIST EN 60862-2:2012

01-oktober-2012

Nadomešča:
SIST EN 60862-2:2003

Filtri za površinske akustične valove (SAW) ocenjene kakovosti - 2. del: Navodilo za uporabo

Surface acoustic wave (SAW) filters of assessed quality - Part 2: Guide to the use

Oberflächenwellenfilter (OFW-Filter) mit bewerteter Qualität - Teil 2: Leitfaden für die Anwendung

ITeH STANDARD PREVIEW
(standards.iteh.ai)

Filtres à ondes acoustiques de surface (OAS) sous assurance de la qualité - Partie 2: Guide d'utilisation

[SIST EN 60862-2:2012](https://standards.iteh.ai/catalog/standards/sist/1c0526ae-25de-4b73-aced-a6ff8f068210/sist-en-60862-2-2012)

<https://standards.iteh.ai/catalog/standards/sist/1c0526ae-25de-4b73-aced-a6ff8f068210/sist-en-60862-2-2012>

Ta slovenski standard je istoveten z: EN 60862-2:2012

ICS:

31.160 Električni filtri Electric filters

SIST EN 60862-2:2012 **en**

iTeh STANDARD PREVIEW
(standards.iteh.ai)

SIST EN 60862-2:2012

<https://standards.iteh.ai/catalog/standards/sist/1c0526ae-25de-4b73-aced-a6ff8f068210/sist-en-60862-2-2012>

EUROPEAN STANDARD
NORME EUROPÉENNE
EUROPÄISCHE NORM

EN 60862-2

August 2012

ICS 31.140

Supersedes EN 60862-2:2002

English version

**Surface acoustic wave (SAW) filters of assessed quality -
Part 2: Guidelines for the use
(IEC 60862-2:2012)**

Filtres à ondes acoustiques de surface
(OAS) sous assurance de la qualité -
Partie 2: lignes directrices d'utilisation
(CEI 60862-2:2012)

Oberflächenwellenfilter (OFW-Filter)
mit bewerteter Qualität -
Teil 2: Leitfaden für die Anwendung
(IEC 60862-2:2012)

iTeh STANDARD PREVIEW

This European Standard was approved by CENELEC on 2012-06-11. CENELEC members are bound to comply with the CEN/CENELEC Internal Regulations which stipulate the conditions for giving this European Standard the status of a national standard without any alteration.

Up-to-date lists and bibliographical references concerning such national standards may be obtained on application to the CEN-CENELEC Management Centre or to any CENELEC member.

This European Standard exists in three official versions (English, French, German). A version in any other language made by translation under the responsibility of a CENELEC member into its own language and notified to the CEN-CENELEC Management Centre has the same status as the official versions.

CENELEC members are the national electrotechnical committees of Austria, Belgium, Bulgaria, Croatia, Cyprus, the Czech Republic, Denmark, Estonia, Finland, Former Yugoslav Republic of Macedonia, France, Germany, Greece, Hungary, Iceland, Ireland, Italy, Latvia, Lithuania, Luxembourg, Malta, the Netherlands, Norway, Poland, Portugal, Romania, Slovakia, Slovenia, Spain, Sweden, Switzerland, Turkey and the United Kingdom.

CENELEC

European Committee for Electrotechnical Standardization
Comité Européen de Normalisation Electrotechnique
Europäisches Komitee für Elektrotechnische Normung

Management Centre: Avenue Marnix 17, B - 1000 Brussels

Foreword

The text of document 49/933/CDV, future edition 3 of IEC 60862-2, prepared by IEC/TC 49 "Piezoelectric, dielectric and electrostatic devices and associated materials for frequency control, selection and detection" was submitted to the IEC-CENELEC parallel vote and approved by CENELEC as EN 60862-2:2012.

The following dates are fixed:

- latest date by which the document has to be implemented at national level by publication of an identical national standard or by endorsement (dop) 2013-03-11
- latest date by which the national standards conflicting with the document have to be withdrawn (dow) 2015-06-11

This document supersedes EN 60862-2:2002.

EN 60862-2:2012 includes the following significant technical changes with respect to EN 60862-2:2002:

- Clause 3 "Terms and definitions" has been deleted to be included in the next edition of EN 60862-1;
- the tapered IDT filter and the RSPUDT filter have been added to the clause of SAW transversal filters. Also DART, DWSF and EWC have been added as variations of SPUDT;
- the balanced connection has been added to the subclause of coupled resonator filters;
- recent substrate materials have been described;
- a subclause about packaging of SAW filters has been added.

Attention is drawn to the possibility that some of the elements of this document may be the subject of patent rights. CENELEC [and/or CEN] shall not be held responsible for identifying any or all such patent rights.

Endorsement notice

The text of the International Standard IEC 60862-2:2012 was approved by CENELEC as a European Standard without any modification.

In the official version, for Bibliography, the following notes have to be added for the standards indicated:

IEC 60862 Series	NOTE	Harmonised as EN 60862 Series (not modified).
IEC 60862-1:2003	NOTE	Harmonised as EN 60862-1:2003 (not modified).
IEC 61019-2:2005	NOTE	Harmonised as EN 61019-2:2005 (not modified).



IEC 60862-2

Edition 3.0 2012-05

INTERNATIONAL STANDARD

NORME INTERNATIONALE



Surface acoustic wave (SAW) filters of assessed quality –
Part 2: Guidelines for the use

Filtres à ondes acoustiques de surface (OAS) sous assurance de la qualité –
Partie 2: Lignes directrices d'utilisation

INTERNATIONAL
ELECTROTECHNICAL
COMMISSION

COMMISSION
ELECTROTECHNIQUE
INTERNATIONALE

PRICE CODE
CODE PRIX

XB

ICS 31.140

ISBN 978-2-88912-074-1

**Warning! Make sure that you obtained this publication from an authorized distributor.
Attention! Veuillez vous assurer que vous avez obtenu cette publication via un distributeur agréé.**

CONTENTS

FOREWORD.....	5
INTRODUCTION.....	7
1 Scope.....	8
2 Normative references	8
3 Technical considerations	8
4 Fundamentals of SAW transversal filters	9
4.1 Frequency response characteristics	9
4.2 Weighting methods.....	10
4.3 Filter configurations and their general characteristics	13
4.3.1 General	13
4.3.2 Bidirectional IDT filters	14
4.3.3 Unidirectional IDT (UDT) filters	15
4.3.4 Tapered IDT filters.....	22
4.3.5 Reflector filters	23
4.3.6 RSPUDT filters	27
5 Fundamentals of SAW resonator filters.....	30
5.1 Classification of SAW resonator filters.....	30
5.2 Ladder and lattice filters	30
5.2.1 Basic structure.....	30
5.2.2 Principle of operation.....	31
5.2.3 Characteristics of ladder and lattice filters	32
5.3 Coupled resonator filters.....	35
5.3.1 General	35
5.3.2 Transversely coupled type	36
5.3.3 Longitudinally coupled type	36
5.3.4 Other characteristics of coupled resonator filters	36
5.3.5 Balanced connection	41
5.4 Interdigitated interdigital transducer (IIDT) resonator filters	45
5.4.1 Configuration.....	45
5.4.2 Principle	45
5.4.3 Characteristics	45
6 Application guidelines.....	46
6.1 Substrate materials and their characteristics	46
6.2 Application to electronics circuits.....	50
6.3 Availability and limitations	52
6.4 Input levels.....	53
6.5 Packaging of SAW filters	54
7 Practical remarks.....	56
7.1 General	56
7.2 Feed-through signals.....	56
7.3 Impedance matching condition	57
7.4 Miscellaneous	57
7.4.1 Soldering conditions	57
7.4.2 Static electricity	57
8 Ordering procedure	58

Bibliography.....	61
Figure 1 – Frequency response of a SAW filter	10
Figure 2 – Applicable range of frequency and relative bandwidth of the SAW filter and the other filters	11
Figure 3 – Schematic diagram showing signal flow through a transversal filter.....	11
Figure 4 – Basic configuration of a SAW transversal filter	12
Figure 5 – Frequency response of the SAW transversal filter shown in Figure 4, where f_0 is the centre frequency and N is the number of finger pairs of the IDT	12
Figure 6 – Apodization weighting obtained by apodizing fingers.....	13
Figure 7 – Withdrawal weighting obtained by selective withdrawal of the fingers.....	13
Figure 8 – Series weighting obtained by the dog-leg structure	13
Figure 9 – Split-finger configuration	14
Figure 10 – Typical characteristics of a SAW IF filter for radio transmission equipment (nominal frequency of 70,0 MHz)	17
Figure 11 – Typical characteristics of a frequency asymmetrical SAW filter (nominal frequency of 58,75 MHz for TV-IF use)	17
Figure 12 – SAW three-IDT filter.....	18
Figure 13 – Typical frequency response of a 900 MHz range SAW filter for communication (mobile telephone use).....	18
Figure 14 – Schematic of the IIDT (multi-IDT) filter.....	19
Figure 15 – Multi-phase unidirectional transducer	19
Figure 16 – Single-phase unidirectional transducers.....	20
Figure 17 – Frequency characteristics of a filter using multi-phase unidirectional transducers.....	21
Figure 18 – Frequency characteristics of a filter using single-phase unidirectional transducers.....	21
Figure 19 – Tapered IDT filter.....	22
Figure 20 – Frequency response of a 140 MHz tapered IDT filter.....	22
Figure 21 – Various reflector filter configurations	24
Figure 22 – Z-path filter configuration	25
Figure 23 – Dual-track reflector filter configuration.....	25
Figure 24 – SPUDT-based dual-track filter.....	26
Figure 25 – Frequency characteristics of Z-path filter.....	26
Figure 26 – Frequency characteristics of dual-track reflector filter.....	27
Figure 27 – Frequency characteristics of SPUDT-based reflector filter.....	27
Figure 28 – A part of DART electrode in RSPUDT filter.....	28
Figure 29 – Distribution of internal reflection and detection inside RSPUDT filter	28
Figure 30 – Frequency and time responses of a 456 MHz RSPUDT filter	29
Figure 31 – Structure of ladder and lattice filters.....	32
Figure 32 – Equivalent circuit of basic section of ladder and lattice filter	33
Figure 33 – Pattern layout of ladder filter	33
Figure 34 – Basic concept of ladder and lattice filter	34
Figure 35 – Typical characteristics of a 1,5 GHz range ladder filter.....	35

Figure 36 – SAW energy distribution and equivalent circuit of transversely coupled resonator filter	37
Figure 37 – Typical characteristics of a transversely coupled resonator filter	38
Figure 38 – Basic configuration and SAW energy distribution of longitudinally coupled resonator filter	39
Figure 39 – Typical characteristics of a longitudinally coupled resonator filter	40
Figure 40 – Configuration of balanced type transversely coupled resonator filter	41
Figure 41 – Frequency characteristics of balanced type transversely coupled resonator filter	42
Figure 42 – Configuration of balanced type longitudinally coupled resonator filter	43
Figure 43 – Typical characteristics of a balanced type longitudinally coupled resonator filter	45
Figure 44 – Schematic of IIDT resonator filter	46
Figure 45 – Frequency characteristics of a 820 MHz range IIDT resonator filter	46
Figure 46 – Minimum theoretical conversion losses for various substrates	48
Figure 47 – Relationship between relative bandwidth and insertion attenuation for various SAW filters, with the practical SAW filters' bandwidth for their typical applications	52
Figure 48 – Ripples in the characteristics of a SAW filter caused by TTE or feed-through signal: $\delta f = 1/(2t)$ for the TTE, and $\delta f = 1/t$ for the feed-through, where t is the delay of the SAW main signal	53
Figure 49 – Example of SAW metal package	54
Figure 50 – Example of SAW ceramic package	55
Figure 51 – Example of SAW resin package	55
Figure 52 – Example of SAW CSP	56
Table 1 – Properties of typical single-crystal substrate materials	50
Table 2 – Properties of typical thin-film substrate materials	50
Table 3 – Properties of typical ceramic substrate materials	50

INTERNATIONAL ELECTROTECHNICAL COMMISSION

**SURFACE ACOUSTIC WAVE (SAW) FILTERS
OF ASSESSED QUALITY –**
Part 2: Guidelines for the use

FOREWORD

- 1) The International Electrotechnical Commission (IEC) is a worldwide organization for standardization comprising all national electrotechnical committees (IEC National Committees). The object of IEC is to promote international co-operation on all questions concerning standardization in the electrical and electronic fields. To this end and in addition to other activities, IEC publishes International Standards, Technical Specifications, Technical Reports, Publicly Available Specifications (PAS) and Guides (hereafter referred to as "IEC Publication(s)"). Their preparation is entrusted to technical committees; any IEC National Committee interested in the subject dealt with may participate in this preparatory work. International, governmental and non-governmental organizations liaising with the IEC also participate in this preparation. IEC collaborates closely with the International Organization for Standardization (ISO) in accordance with conditions determined by agreement between the two organizations.
- 2) The formal decisions or agreements of IEC on technical matters express, as nearly as possible, an international consensus of opinion on the relevant subjects since each technical committee has representation from all interested IEC National Committees.
- 3) IEC Publications have the form of recommendations for international use and are accepted by IEC National Committees in that sense. While all reasonable efforts are made to ensure that the technical content of IEC Publications is accurate, IEC cannot be held responsible for the way in which they are used or for any misinterpretation by any end user.
- 4) In order to promote international uniformity, IEC National Committees undertake to apply IEC Publications transparently to the maximum extent possible in their national and regional publications. Any divergence between any IEC Publication and the corresponding national or regional publication shall be clearly indicated in the latter.
- 5) IEC itself does not provide any attestation of conformity. Independent certification bodies provide conformity assessment services and, in some areas, access to IEC marks of conformity. IEC is not responsible for any services carried out by independent certification bodies.
- 6) All users should ensure that they have the latest edition of this publication.
- 7) No liability shall attach to IEC or its directors, employees, servants or agents including individual experts and members of its technical committees and IEC National Committees for any personal injury, property damage or other damage of any nature whatsoever, whether direct or indirect, or for costs (including legal fees) and expenses arising out of the publication, use of, or reliance upon, this IEC Publication or any other IEC Publications.
- 8) Attention is drawn to the Normative references cited in this publication. Use of the referenced publications is indispensable for the correct application of this publication.
- 9) Attention is drawn to the possibility that some of the elements of this IEC Publication may be the subject of patent rights. IEC shall not be held responsible for identifying any or all such patent rights.

International Standard IEC 60862-2 has been prepared by IEC technical committee 49: Piezoelectric, dielectric and electrostatic devices and associated materials for frequency control, selection and detection.

This third edition cancels and replaces the second edition published in 2002 and constitutes a technical revision.

This edition includes the following significant technical changes with respect to the previous edition:

- Clause 3-"Terms and definitions" has been deleted to be included in the next edition of IEC 60862-1;
- the tapered IDT filter and the RSPUDT filter have been added to the clause of SAW transversal filters. Also DART, DWSF and EWC have been added as variations of SPUDT;
- the balanced connection has been added to the subclause of coupled resonator filters;

- recent substrate materials have been described;
- a subclause about packaging of SAW filters has been added.

The text of this standard is based on the following documents:

CDV	Report on voting
49/933/CDV	49/970A/RVC

Full information on the voting for the approval of this standard can be found in the report on voting indicated in the above table.

This publication has been drafted in accordance with the ISO/IEC Directives, Part 2.

A list of all parts of the IEC 60862 series, published under the general title *Surface acoustic wave (SAW) filters of assessed quality*, can be found on the IEC web site.

The committee has decided that the contents of this publication will remain unchanged until the stability date indicated on the IEC web site under "<http://webstore.iec.ch>" in the data related to the specific publication. At this date, the publication will be

- reconfirmed,
- withdrawn,
- replaced by a revised edition, or
- amended.

ITEH STANDARD PREVIEW
(standards.iteh.ai)

SIST EN 60862-2:2012
<http://standards.iteh.ai/catalog/standards/sist/1e0510aa-25dc-4b19-8cc0-a01b1000210/sist-en-60862-2-2012>

IMPORTANT – The 'colour inside' logo on the cover page of this publication indicates that it contains colours which are considered to be useful for the correct understanding of its contents. Users should therefore print this document using a colour printer.

INTRODUCTION

This standard has been compiled in response to a generally expressed desire on the part of both users and manufacturers for guidance on the use of SAW filters, so that the filters may be used to their best advantage. To this end, general and fundamental characteristics have been explained here.

The features of these SAW filters are their small size, light weight, adjustment-free, high stability and high reliability. SAW filters add new features and applications to the field of crystal filters and ceramic filters. At the beginning, SAW filters meant transversal filters which have two interdigital transducers (IDT). Although SAW transversal filters have a relatively higher minimum insertion attenuation, they have excellent amplitude and phase characteristics. Extensive studies have been made to reduce minimum insertion attenuation, such as resonator filter configurations, unidirectional interdigital transducers (UDT), interdigitated interdigital transducers (IIDT). Nowadays, various kinds of SAW filters with low insertion attenuation are widely used in various applications and SAW filters are available in the gigahertz range.

iTeh STANDARD PREVIEW **(standards.iteh.ai)**

[SIST EN 60862-2:2012](https://standards.iteh.ai/catalog/standards/sist/1c0526ae-25de-4b73-aced-a6ff8f068210/sist-en-60862-2-2012)

<https://standards.iteh.ai/catalog/standards/sist/1c0526ae-25de-4b73-aced-a6ff8f068210/sist-en-60862-2-2012>

SURFACE ACOUSTIC WAVE (SAW) FILTERS OF ASSESSED QUALITY –

Part 2: Guidelines for the use

1 Scope

This part of IEC 60862 gives practical guidance on the use of SAW filters which are used in telecommunications, measuring equipment, radar systems and consumer products. IEC 60862-1 should be referred to for general information, standard values and test conditions.

SAW filters are now widely used in a variety of applications such as TV, satellite communications, optical fibre communications, mobile communications and so on. While these SAW filters have various specifications, many of them can be classified within a few fundamental categories.

This part of IEC 60862 includes various kinds of filter configuration, of which the operating frequency range is from approximately 10 MHz to 3 GHz and the relative bandwidth is about 0,02 % to 50 % of the centre frequency.

It is not the aim of this standard to explain theory, nor to attempt to cover all the eventualities which may arise in practical circumstances. This standard draws attention to some of the more fundamental questions, which should be considered by the user before he places an order for a SAW filter for a new application. Such a procedure will be the user's insurance against unsatisfactory performance.

Standard specifications, given in IEC 60862 series, and national specifications or detail specifications issued by manufacturers, define the available combinations of nominal frequency, pass bandwidth, ripple, shape factor, terminating impedance, etc. These specifications are compiled to include a wide range of SAW filters with standardized performances. It cannot be over-emphasized that the user should, wherever possible, select his SAW filters from these specifications, when available, even if it may lead to making small modifications to his circuit to enable standard filters to be used. This applies particularly to the selection of the nominal frequency.

2 Normative references

The following documents, in whole or in part, are normatively referenced in this document and are indispensable for its application. For dated references, only the edition cited applies. For undated references, the latest edition of the referenced document (including any amendments) applies.

None.

3 Technical considerations

It is of prime interest to a user that the filter characteristics should satisfy a particular specification. The selection of tuning networks and SAW filters to meet that specification should be a matter of agreement between the user and the manufacturer.

Filter characteristics are usually expressed in terms of insertion attenuation and group delay as a function of frequency, as shown in Figure 1. A standard method for measuring insertion attenuation and group delay is described in 4.5.2 of IEC 60862-1:2003. In some applications, such characteristics as phase distortion are also important.

Insertion attenuation characteristics are further specified by nominal frequency, minimum insertion attenuation or maximum insertion attenuation, pass-band ripple and shape factor. The specification is to be satisfied between the lowest and highest temperatures of the specified operating temperature range and before and after environmental tests.

SAW filters are classified roughly into two types: transversal filters and resonator filters. Transversal filters are further classified into five types: bidirectional IDT filter, unidirectional IDT filter, tapered IDT filter, reflector filter and RSPUDT (resonant single-phase unidirectional transducer) filter. Also resonator filters are further classified into three types i.e. ladder and lattice filters, coupled resonator filter and IIDT resonator filter. Fundamentals of SAW transversal filters and SAW resonator filters are described in Clauses 4 and 5 of this standard, respectively. In Figure 2, the applicable frequency range and relative bandwidth of the SAW filters are shown in comparison with those of ceramic, crystal, dielectric, helical and stripline filters.

4 Fundamentals of SAW transversal filters

4.1 Frequency response characteristics

A brief description of SAW filters is given here to help users unfamiliar with these filters to understand their operating principles and characteristics. The SAW filter uses a surface acoustic wave, usually the Rayleigh wave. The mechanical energy transported by the wave is concentrated in a surface region of the order of a wavelength in depth. The wave travels on a solid surface at a velocity, 10^3 m/s to 10^4 m/s, which offers the possibility of filtering operations in the VHF and UHF regions in practical SAW filters. The SAW filter has a planar structure, in which electrodes are formed on one surface of a piezoelectric substrate, incorporating a suitable configuration of electrodes as a means of conversion between surface acoustic waves and electrical signals.

Figure 3 is a diagram showing the signal flow through a transversal filter. The filter consists of N taps separated by delays D_n . Each tap is weighted by a coefficient A_n . Filtering is achieved by passing the signal through a number of delay paths and adding these delayed signals. The delays correspond to the positions of IDT fingers on a substrate. The coefficients correspond to weighting coefficients given to the IDT fingers. The frequency response of the filter $H(f)$ is given by a discrete Fourier transformation, expressed as the following Equation (1) at a frequency f :

$$H(f) = \sum_{n=1}^N A_n \exp(-j2\pi f T_n) \quad T_n = \sum_{i=1}^n D_i \quad (1)$$

where T_n is the accumulated delay at the n th tap.

Both amplitude and phase characteristics of the transversal filter are given by two sets of variables: weighting coefficients A_n and delays D_n of the sampling taps.

The SAW transversal filter is essentially constructed with a pair of transducers on a piezoelectric substrate as shown in Figure 4. When an electrical signal is applied to the input IDT, the surface wave is generated by means of the piezoelectric effect and propagates in both directions along the substrate surface. The surface wave is converted again into an electrical signal at the output IDT. If the IDT spatial period $2d$ is uniform, maximum conversion efficiency can be achieved at the frequency for which the surface wave propagates one

transducer period synchronously in one RF signal period. The centre frequency f_0 of the IDT is given by this synchronization condition:

$$2df_0 = v_s \quad (2)$$

where v_s is the SAW velocity.

When the SAW transversal filter has two uniform identical transducers, its frequency response is as shown in Figure 5. The transfer function $T(f)$ is approximately expressed as:

$$T(f) = \left(\frac{\sin x}{x} \right)^2 \quad (3)$$

where

$$x = \frac{N\pi(f - f_0)}{f_0} \text{ and}$$

N is the number of finger pairs.

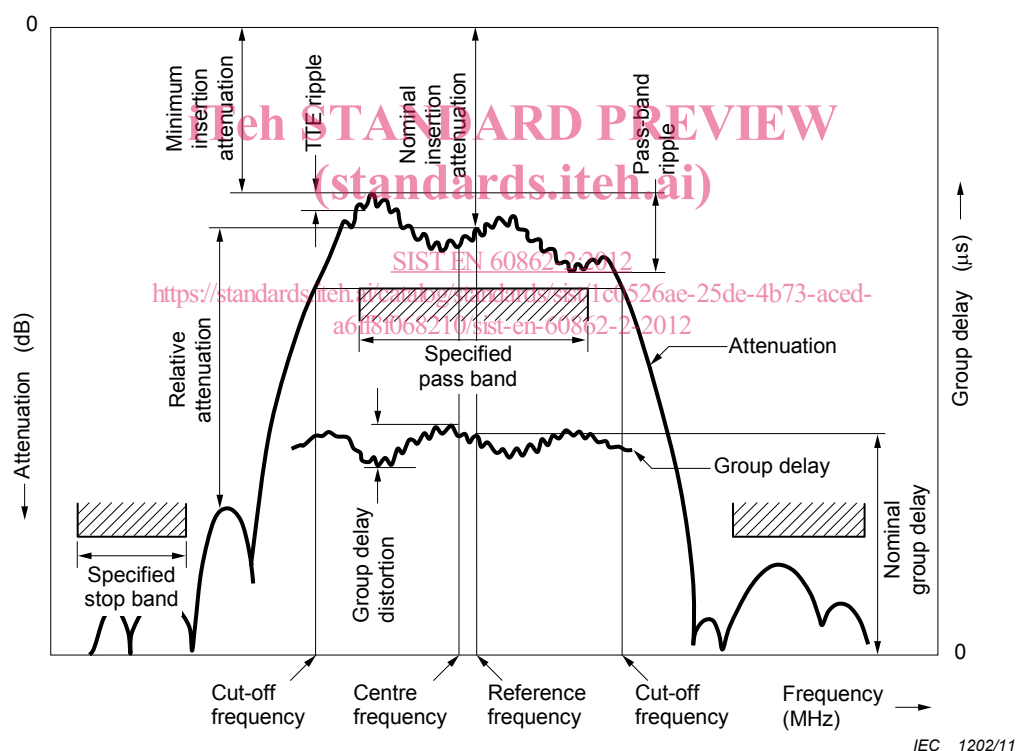

Figure 1 – Frequency response of a SAW filter

4.2 Weighting methods

The IDT operates as a kind of transversal filter with N taps for the weighting. A number of weighting methods are applicable, for example apodization, withdrawal and series (dog-leg) weighting.

a) Apodization weighting

An apodized transducer, as shown in Figure 6, is most commonly used to achieve weighting. An acoustic wave is generated or detected only in regions where adjacent electrodes of opposite polarity overlap.

b) Withdrawal weighting

Weighting is achieved by selectively withdrawing electrodes, as illustrated in Figure 7, to equate with the desired weighting function.

c) Series (dog-leg) weighting

Weighting is achieved by dividing the voltage by segmenting each electrode pair, as shown in Figure 8.

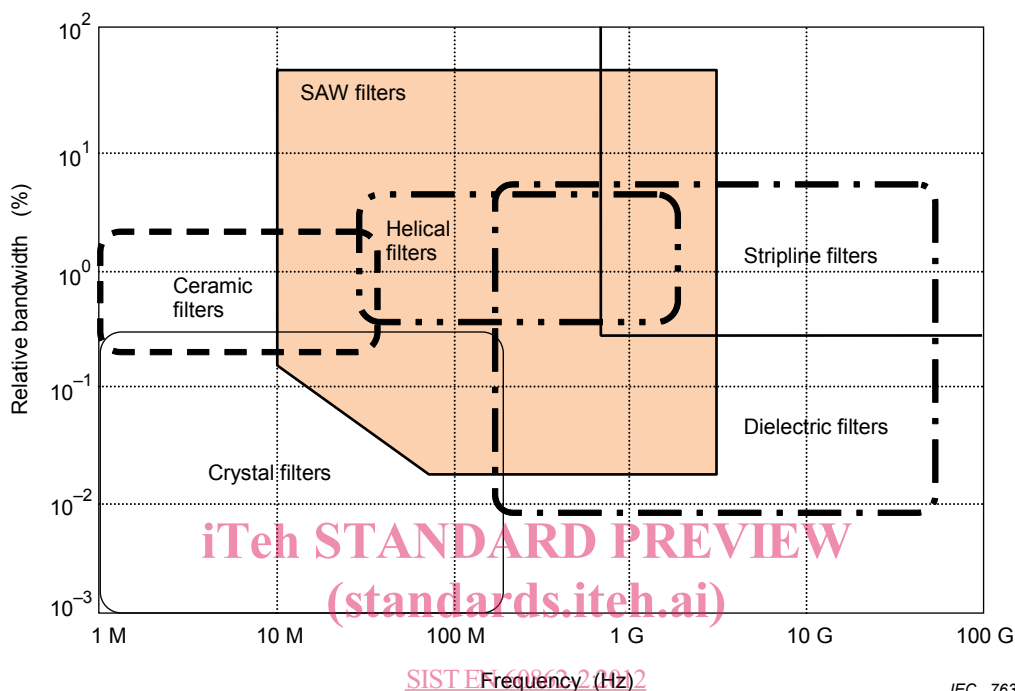

Figure 2 – Applicable range of frequency and relative bandwidth of the SAW filter and the other filters

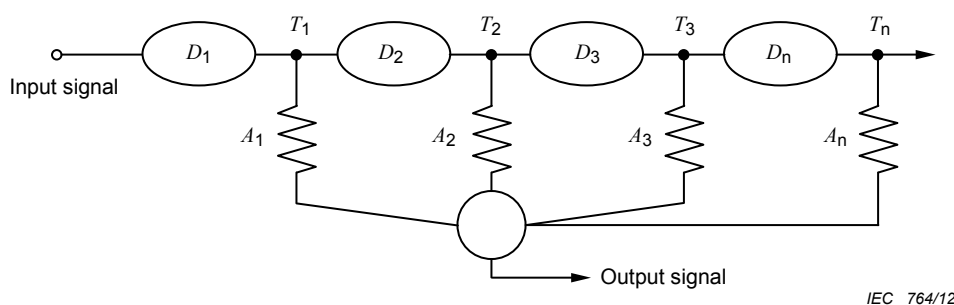

Figure 3 – Schematic diagram showing signal flow through a transversal filter