

INTERNATIONAL STANDARD

ISO 123

Third edition
2001-05-15

Rubber latex — Sampling

Latex de caoutchouc — Échantillonnage

iTeh STANDARD PREVIEW
(standards.iteh.ai)

ISO 123:2001

<https://standards.iteh.ai/catalog/standards/sist/f770bb95-8b31-4965-b3d6-7958f3e86a2f/iso-123-2001>



Reference number
ISO 123:2001(E)

© ISO 2001

PDF disclaimer

This PDF file may contain embedded typefaces. In accordance with Adobe's licensing policy, this file may be printed or viewed but shall not be edited unless the typefaces which are embedded are licensed to and installed on the computer performing the editing. In downloading this file, parties accept therein the responsibility of not infringing Adobe's licensing policy. The ISO Central Secretariat accepts no liability in this area.

Adobe is a trademark of Adobe Systems Incorporated.

Details of the software products used to create this PDF file can be found in the General Info relative to the file; the PDF-creation parameters were optimized for printing. Every care has been taken to ensure that the file is suitable for use by ISO member bodies. In the unlikely event that a problem relating to it is found, please inform the Central Secretariat at the address given below.

iTeh STANDARD PREVIEW
(standards.iteh.ai)

ISO 123:2001

<https://standards.iteh.ai/catalog/standards/sist/f770bb95-8b31-4965-b3d6-7958f3e86a2f/iso-123-2001>

© ISO 2001

All rights reserved. Unless otherwise specified, no part of this publication may be reproduced or utilized in any form or by any means, electronic or mechanical, including photocopying and microfilm, without permission in writing from either ISO at the address below or ISO's member body in the country of the requester.

ISO copyright office
Case postale 56 • CH-1211 Geneva 20
Tel. + 41 22 749 01 11
Fax + 41 22 749 09 47
E-mail copyright@iso.ch
Web www.iso.ch

Printed in Switzerland

Contents

	Page
1 Scope	1
2 Normative references	1
3 Terms and definitions	1
4 Principle	2
5 Apparatus	2
6 Sampling	3
7 Labelling the laboratory sample and the test sample	7
8 Sampling report	8

iTeh STANDARD PREVIEW
(standards.iteh.ai)

ISO 123:2001

<https://standards.iteh.ai/catalog/standards/sist/f770bb95-8b31-4965-b3d6-7958f3e86a2f/iso-123-2001>

Foreword

ISO (the International Organization for Standardization) is a worldwide federation of national standards bodies (ISO member bodies). The work of preparing International Standards is normally carried out through ISO technical committees. Each member body interested in a subject for which a technical committee has been established has the right to be represented on that committee. International organizations, governmental and non-governmental, in liaison with ISO, also take part in the work. ISO collaborates closely with the International Electrotechnical Commission (IEC) on all matters of electrotechnical standardization.

International Standards are drafted in accordance with the rules given in the ISO/IEC Directives, Part 3.

Draft International Standards adopted by the technical committees are circulated to the member bodies for voting. Publication as an International Standard requires approval by at least 75 % of the member bodies casting a vote.

Attention is drawn to the possibility that some of the elements of this International Standard may be the subject of patent rights. ISO shall not be held responsible for identifying any or all such patent rights.

International Standard ISO 123 was prepared by Technical Committee ISO/TC 45, *Rubber and rubber products*, Subcommittee SC 3, *Raw materials (including latex) for use in the rubber industry*.

This third edition cancels and replaces the second edition (ISO 123:1985), which has been technically revised. The principal differences lie in more precise definitions and specifications for the frequency of sampling. In addition, the method of homogenizing and sampling latex in drums fitted with bungs has been modified to take account of practical considerations.

ISO 123:2001

<https://standards.iteh.ai/catalog/standards/sist/f770bb95-8b31-4965-b3d6-7958f3e86a2f/iso-123-2001>

Rubber latex — Sampling

WARNING — Persons using this International Standard should be familiar with normal laboratory practice. This standard does not purport to address all of the safety problems, if any, associated with its use. It is the responsibility of the user to establish appropriate safety and health practices and to ensure compliance with any national regulatory conditions.

1 Scope

This International Standard specifies procedures for sampling natural rubber latex concentrate and for sampling synthetic rubber latices and artificial latices. It is also suitable for sampling rubber latex contained in drums, tank cars or tanks. The procedures may also be used for sampling plastics dispersions.

2 Normative references

The following normative documents contain provisions which, through reference in this text, constitute provisions of this International Standard. For dated references, subsequent amendments to, or revisions of, any of these publications do not apply. However, parties to agreements based on this International Standard are encouraged to investigate the possibility of applying the most recent editions of the normative documents indicated below. For undated references, the latest edition of the normative document referred to applies. Members of ISO and IEC maintain registers of currently valid International Standards. [ISO 123:2001](https://standards.iteh.ai/catalog/standards/sist/f770bb95-8b31-4965-b3d6-)

<https://standards.iteh.ai/catalog/standards/sist/f770bb95-8b31-4965-b3d6->

ISO 124:1997, *Latex, rubber — Determination of total solids content.*

ISO 706:1985, *Rubber latex — Determination of coagulum content (sieve residue).*

ISO 3310-1:2000, *Test sieves — Technical requirements and testing — Part 1: Test sieves of metal wire cloth.*

ISO 15528:2000, *Paints, varnishes and raw materials for paints and varnishes — Sampling.*

3 Terms and definitions

For the purposes of this International Standard, the following terms and definitions apply.

3.1

lot

a definite quantity of latex processed or produced under conditions which are presumed uniform

NOTE A lot may be in one or more containers or vessels. For example, it may consist of several drums of latex.

3.2

sample

a quantity of latex that has been drawn from a lot

3.3

laboratory sample

a quantity of latex intended for laboratory inspection and testing and that is representative of the lot

3.4

test sample

a quantity of latex suitable for testing, obtained by straining the laboratory sample

NOTE The laboratory sample, not the test sample, is used for the determination of coagulum content (see 6.5.5).

3.5

test portion

a quantity of latex taken from the test sample (3.4) or laboratory sample (3.3), for the purpose of a single specific test, for example the amount actually weighed out from the test sample for a single determination of total solids content

3.6

coagulum content/sieve residue

coarse foreign matter and flocculated rubber retained under the conditions of the test (ISO 706) on a filter with average aperture width of $180 \mu\text{m} \pm 10 \mu\text{m}$ complying with ISO 3310-1

NOTE In the context of examination of latex shipments, bulk deliveries, etc., this is what is generally understood by "coagulum". Pieces of latex skin and coagulated rubber should not be included in the laboratory sample.

4 Principle

A representative laboratory sample is taken from the bulk of the latex. The test sample is prepared by straining the laboratory sample.

5 Apparatus

iTeh STANDARD PREVIEW
(standards.iteh.ai)

No part of the equipment to be immersed in the latex shall contain copper.

5.1 Stirrer, for homogenization of latex in drums. [ISO 123:2001](https://standards.iteh.ai/catalog/standards/sist/f770bb95-8b31-4965-b3d6-755819c86a2f/iso-123-2001)

For open-headed drums, use either 5.1.1 or 5.1.2. For drums fitted with a bung, see 6.4.1.4.

5.1.1 Plunger, consisting of a perforated, chrome-plated or stainless-steel disc of diameter approximately 150 mm, with smooth-edged holes of diameter approximately 10 mm.

5.1.2 Motor-driven stirrer, capable of operating at a speed of 5 rad/s to 21 rad/s (50 r/min to 200 r/min).

A suitable type of motor-driven stirrer consists of a stainless-steel propeller of 110 mm minimum diameter, mounted on a stainless-steel shaft sufficiently long for the propeller to be at a distance of about one-tenth the depth of the latex from the bottom of the drum.

If desired, two propellers may be used on the same shaft, in which case the lower one shall meet the foregoing requirements as regards position. The rotational frequency shall be such as to give a brisk turnover without creating a vortex.

5.1.3 Motor-driven drum roller (optional, see 6.4.1.5), capable of rotating a drum at approximately 1 rad/s (10 r/min).

5.2 Sampling devices, suitable for the removal of an approximately 1 dm^3 representative sample from a known depth in the latex. Such devices shall be constructed of materials inert to latex.

5.2.1 Sampling tubes for latex in drums

Use either 5.2.1.1 or 5.2.1.2.

5.2.1.1 Sampling tube, of material inert to the latex, such as glass, stainless steel or inert plastic, having an internal diameter of 10 mm to 15 mm and a length of at least 1 m, open at both ends and having a stopper for closing the upper end while withdrawing it from the latex.

NOTE Inserting a tube open at both ends into the latex effectively provides a cross-section of the latex at all depths as a sample.

5.2.1.2 Sampling tube, stainless steel, of internal diameter approximately 25 mm and length at least 1 m, the bottom of which can be opened or closed by remote control. A drawing of a suitable device is given in Figure 1.

5.2.2 Sampling devices for latex in tank cars or tanks

Use 5.2.2.1 if the depth of the latex is 3 m or more. Use either 5.2.2.1 or 5.2.2.2 if the depth is less than 3 m.

5.2.2.1 Cylindrical stainless-steel vessel, of capacity approximately 1 dm³, closed by a lid or bung that can be opened by remote control. Such a vessel may be rigidly mounted for insertion to the required depth. A device similar to that shown in Figure 2 is suitable. A variety of other suitable devices for sampling are given in ISO 15528.

5.2.2.2 Sampling tube, stainless steel, of internal diameter 25 mm, similar to 5.2.1.2 but length 3 m, the bottom of which can be opened or closed by remote control.

5.3 Beakers, of capacity 2 dm³, to receive the latex from the sampling tube or vessel. The beakers shall be shock-resistant and have a smooth inner surface that is chemically inert to latex.

5.4 Sample bottles, of capacity 1 dm³, with screw caps. The bottles shall have a smooth inner surface and be made of material that is chemically resistant to latex. Glass and some types of plastic are suitable materials. Thin flexible containers shall not be used.

NOTE For purposes of trans-shipment, narrow-necked containers with a deep thread are preferable.

5.5 Filter, of stainless-steel wire or synthetic cloth inert to latex, with an average aperture width of 180 µm ± 10 µm, complying with ISO 3310-1.

iTech STANDARD PREVIEW
(standards.iteh.ai)
<https://standards.iteh.ai/catalog/standards/sist/f770bb95-8b31-4965-b3d6-7958f3e86a2f/iso-123-2001>

6 Sampling

6.1 General

At all stages of sampling, avoid introducing air into the latex and keep exposure of the latex to air to a minimum.

6.2 Frequency of sampling

6.2.1 Unless otherwise agreed, sampling shall be carried out at the frequency specified in 6.2.2 and 6.2.3.

6.2.2 Every lot shall be sampled.

6.2.3 Where a lot has been divided between a number of distinct containers (e.g. drums), samples shall be taken from 10 % of the containers with a minimum of one and rounded up to the nearest whole number (i.e. two from twelve, seven from sixty-four, etc.).

Select the containers from which the samples are to be withdrawn at random throughout the consignment.

6.3 Preliminary examination

Examine the latex visually, and record the presence of creaming, gross coagulum, skin and foreign matter.

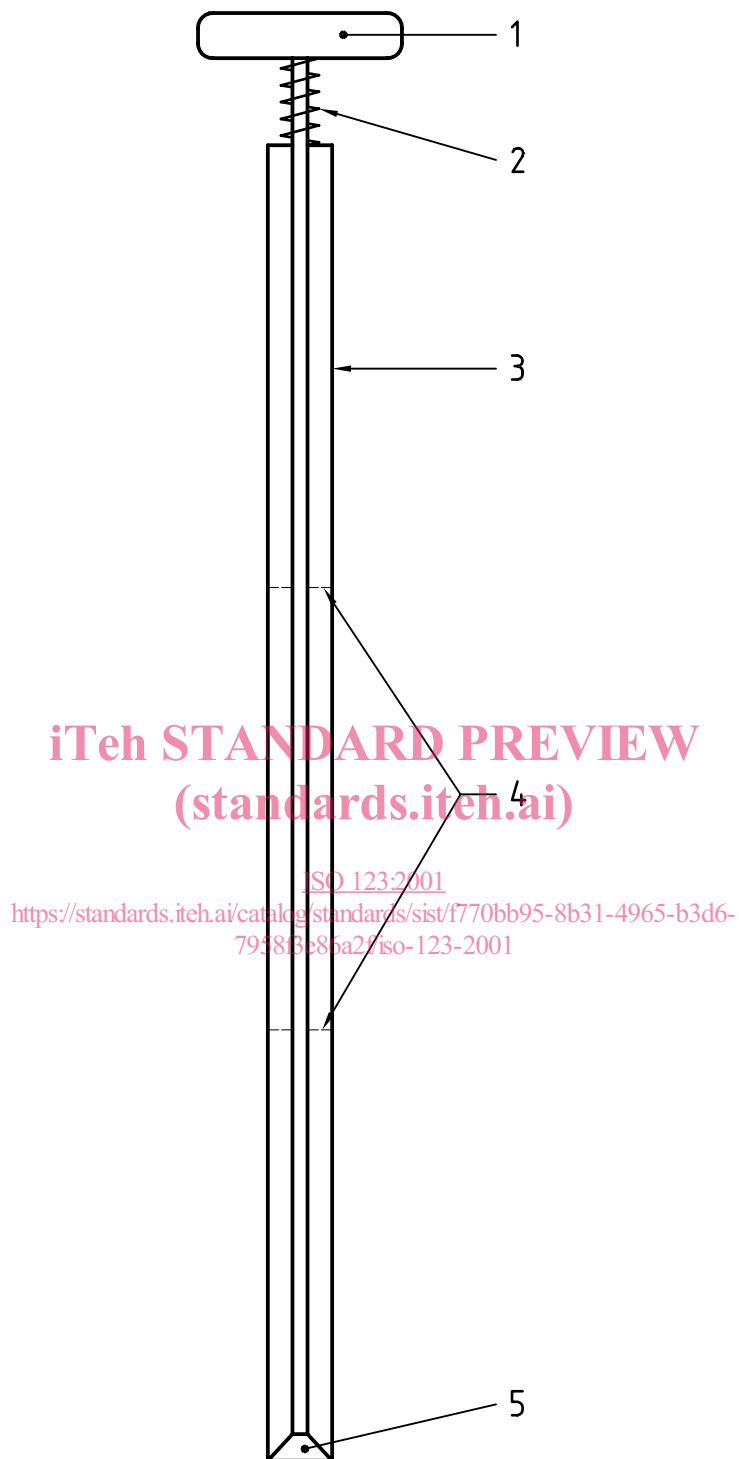

Key

- 1 Handle
- 2 Spring
- 3 Tube
- 4 Guides for valve rod
- 5 Simple valve

Figure 1 — Sampling tube for drums, tank cars and smaller tanks (not to scale)

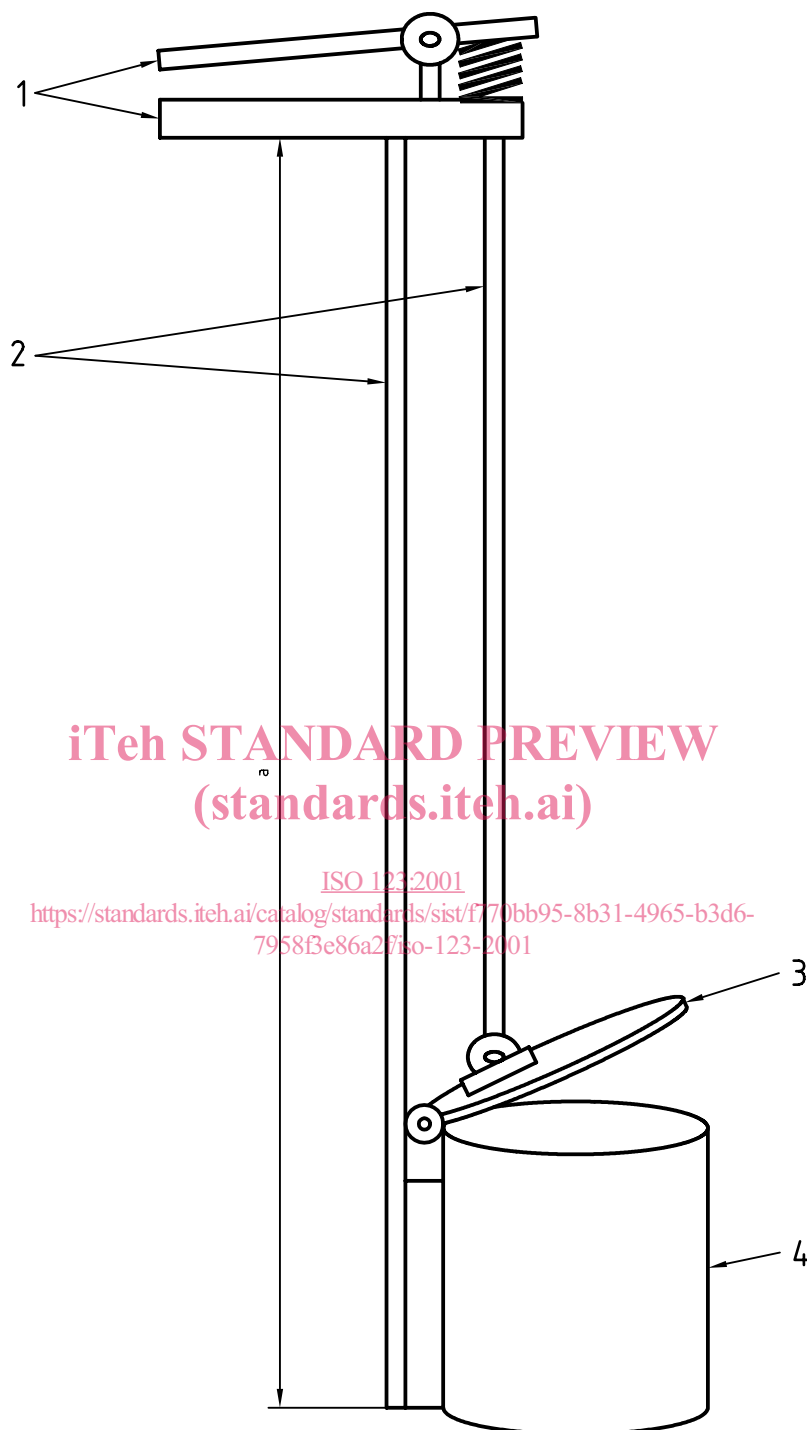
**Key**

- 1 Handle (manual compression opens lid)
- 2 Rods
- 3 Lid
- 4 Container of appropriate size

^a Suitable length for taking sample

Construction material: stainless steel

Figure 2 — Example of a latex-sampling device