



SLOVENSKI STANDARD SIST ISO 2971:1998

01-september-1998

7][UfYhY'jb'Z]fj]'8c`c Yj UbY'bc a]bUby[UX]Ua YfU!'AYfcXU'i dcfUVY'a Yf]b]\
bUdfUj 'n`UgUfg_]a `yUf_ca

Cigarettes and filter rods -- Determination of nominal diameter -- Method using a laser beam measuring apparatus

iTeh STANDARD PREVIEW

Cigarettes et bâtonnets-filtres -- Détermination du diamètre nominal -- Méthode utilisant un instrument de mesure à faisceau laser

[SIST ISO 2971:1998](https://standards.iteh.ai/catalog/standards/sist/87e3216d-3399-4bba-af70-aa2826c2f7f5/sist-iso-2971-1998)

Ta slovenski standard je istoveten z: **ISO 2971:1998**

ICS:

65.160 V[àæ É[àæ } àæ à^ \ àæ Tobacco, tobacco products
[] ! ^ { æ and related equipment

SIST ISO 2971:1998

en

iTeh STANDARD PREVIEW
(standards.iteh.ai)

SIST ISO 2971:1998

<https://standards.iteh.ai/catalog/standards/sist/87e3216d-3399-4bba-af70-aa2828e2f7f5/sist-iso-2971-1998>

INTERNATIONAL
STANDARD

ISO
2971

Third edition
1998-08-01

**Cigarettes and filter rods — Determination
of nominal diameter — Method using a
laser beam measuring apparatus**

*Cigarettes et bâtonnets-filtres — Détermination du diamètre nominal —
Méthode utilisant un instrument de mesure à faisceau laser*

iTeh STANDARD PREVIEW
(standards.iteh.ai)

[SIST ISO 2971:1998](https://standards.iteh.ai/catalog/standards/sist/87e3216d-3399-4bba-af70-aa2828e2f7f5/sist-iso-2971-1998)

[https://standards.iteh.ai/catalog/standards/sist/87e3216d-3399-4bba-af70-
aa2828e2f7f5/sist-iso-2971-1998](https://standards.iteh.ai/catalog/standards/sist/87e3216d-3399-4bba-af70-aa2828e2f7f5/sist-iso-2971-1998)



Reference number
ISO 2971:1998(E)

ISO 2971:1998(E)**Foreword**

ISO (the International Organization for Standardization) is a worldwide federation of national standards bodies (ISO member bodies). The work of preparing International Standards is normally carried out through ISO technical committees. Each member body interested in a subject for which a technical committee has been established has the right to be represented on that committee. International organizations, governmental and non-governmental, in liaison with ISO, also take part in the work. ISO collaborates closely with the International Electrotechnical Commission (IEC) on all matters of electrotechnical standardization.

Draft International Standards adopted by the technical committees are circulated to the member bodies for voting. Publication as an International Standard requires approval by at least 75 % of the member bodies casting a vote.

International Standard ISO 2971 was prepared by Technical Committee ISO/TC 126, *Tobacco and tobacco products*, Subcommittee SC 1, *Physical and dimensional tests*.

This third edition cancels and replaces the second edition (ISO 2971:1987), which has been technically revised.

Annex A forms an integral part of this International Standard. Annexes B and C are for information only.

© ISO 1998

All rights reserved. Unless otherwise specified, no part of this publication may be reproduced or utilized in any form or by any means, electronic or mechanical, including photocopying and microfilm, without permission in writing from the publisher.

International Organization for Standardization
Case postale 56 • CH-1211 Genève 20 • Switzerland
Internet iso@iso.ch

Printed in Switzerland

Cigarettes and filter rods — Determination of nominal diameter — Method using a laser beam measuring apparatus

1 Scope

This International Standard specifies a non-contact, scanning laser beam method of gauging for determination of the mean, minimum and maximum diameters and the ovality of rod-shaped objects with a circular or oval cross-section. The method is applicable, in particular, to cigarettes and filter rods.

NOTE 1 Alternative tape gauge and pneumatic balancing orifice measurement techniques are still widely used in the determination of nominal diameters for cigarettes and filter rods. These alternative measurement techniques are discussed in annex C.

NOTE 2 For laboratories using the circumference value instead of the diameter, the circumference value is calculated by multiplying the diameter by pi (π).

iTeh STANDARD PREVIEW
(standards.iteh.ai)

[SIST ISO 2971:1998](#)

[standards.iteh.ai/catalog/standards/sist/87e3216d-3399-4bba-af70-aa2828e2f7f5/sist-iso-2971-1998](#)

2 Normative reference

The following standard contains provisions which, through reference in this text, constitute provisions of this International Standard. At the time of publication, the edition indicated was valid. All standards are subject to revision, and parties to agreements based on this International Standard are encouraged to investigate the possibility of applying the most recent edition of the standard indicated below. Members of IEC and ISO maintain registers of currently valid International Standards.

ISO 3402:1991, *Tobacco and tobacco products — Atmosphere for conditioning and testing*.

3 Definitions

For the purposes of this International Standard, the following definitions apply.

3.1 diameter

arithmetic mean value of a minimum of n readings ($n \geq 100$) performed on a test piece following the method specified in this International Standard

NOTE The diameter is valid as a parameter for rod-like test pieces with a nearly circular cross-section.

3.2 minimum diameter

minimum value obtained from the results of n individual readings performed on a test piece

3.3

maximum diameter

maximum value obtained from the results of n individual readings performed on a test piece

3.4

absolute ovality

expression of the out-of-roundness of a rod-like test piece with an oval cross-section

NOTE It can be obtained from the arithmetic difference between the maximum and minimum diameters obtained from n individual readings.

3.5

relative ovality

ratio of the arithmetic difference between the absolute ovality and the diameter calculated from n individual readings

NOTE 1 Relative ovality is expressed as a percentage.

NOTE 2 Caution should be exercised in interpreting maximum diameters, absolute ovality and relative ovality as these can be affected by the quality of the gum line (raised laps), generating artificially high individual diameter readings.

4 Principle

Using the appropriate device of the apparatus, the test piece is rotated around its longitudinal axis, for a half (180°) or full (360°) rotation, with a constant angular (rotational) speed. Simultaneously, the laser beam moves, parallel to itself, with constant speed, in a plane (called the scan path) which is perpendicular to the longitudinal axis of the test piece.

The intersection of the scan path with the test piece is a cross-section of the test piece.

An individual reading is the measured length of the orthogonal projection of this cross-section on a plane parallel to the axis of the test piece.

This principle is illustrated in figure 1.

5 Apparatus

5.1 Sample conditioning enclosure, capable of maintaining the conditions given in ISO 3402.

5.2 Scanning laser beam measuring apparatus, consisting of the following.

5.2.1 Scanning laser beam measuring instrument, having a resolution of at least 0,005 mm, for the determination of the diameter of rod-like test pieces with a nearly circular cross-section.

The scanning velocity of the laser shall be such that no eccentric motion of the test piece parallel to the longitudinal axis, within the measurement area, shall affect the accuracy of the measurement of mean diameter.

The ratio between the scanning rate of the laser beam apparatus and the rotational speed of the test piece shall be constant and high enough to ensure that the measured diameter, as well as the minimum and maximum values, shall be determined with sufficient accuracy, in spite of possible ovality of the test piece.

The length of the scan path shall be at least 50 % greater than the maximum diameter to be measured and the test piece shall be scanned a minimum of 100 times by the laser beam during a half (180°) or full (360°) rotation.

5.2.2 Apparatus or fixture for rotating the test piece in the scan path of the laser beam or to rotate the scan path of the laser around the test piece while maintaining the longitudinal axis of the test piece perpendicular to the scan path.

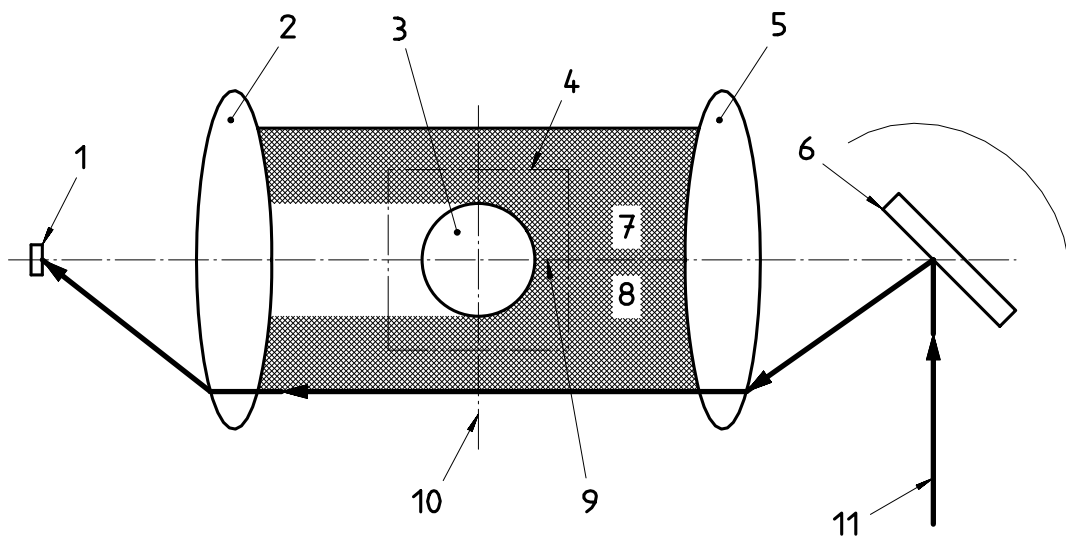
**Key**

- 1 Receiving element
- 2 Converging lens
- 3 Test piece
- 4 Measurement area
- 5 Collimator lens
- 6 Scanning mirror
- 7 to 8 Scan path
- 9 Scan centreline
- 10 Measurement line
- 11 Laser beam

iTeh STANDARD PREVIEW
(standards.iteh.ai)

[SIST ISO 2971:1998](https://standards.iteh.ai/catalog/standards/sist/87e3216d-3399-4bba-af70-aa2828e2f7f5/sist-iso-2971-1998)

<https://standards.iteh.ai/catalog/standards/sist/87e3216d-3399-4bba-af70-aa2828e2f7f5/sist-iso-2971-1998>

NOTE For a single-axis scanner, the measurement area surrounds an ideal location found at the intersection of the measurement line and the scan centreline. Best accuracy is achieved when the test piece is within the measurement area.

Figure 1 — Diagram of a single-axis (laser scanner) gauging system

6 Sampling

Take a statistically representative sample of the population of test pieces to be characterized.

Samples shall be free of obvious visible defects which may impair measurement performance.

7 Procedure

7.1 Preparation of test pieces

Select at random, from the sample taken in accordance with clause 6, the number of test pieces required for the test.

Condition the test pieces, prior to measurement, in a conditioning enclosure in accordance with ISO 3402.

The times required for the curing of filter rods and the duration of conditioning for both filter rods and cigarettes are not specified in this International Standard and are to be determined by practical experience. They shall be reported in the test report together with the results.

7.2 Calibration

Working standards are routinely used to calibrate or check the calibration of the laser scanning system. Calibration shall be performed with a minimum of two standards, differing in size by at least 25 % of the measurement range of the instrument, and of dimensions known to accuracies beyond those required for measurement.

The sizes of the test pieces to be measured shall be within the range of those of the calibration standards.

NOTE 1 One intermediate standard can be used on a routine check; its diameter should be near to that of the test piece.

NOTE 2 The essential properties of calibration standards are given in annex A.

7.3 Measurement

In accordance with the manufacturer's instructions, position the test piece within the measurement area, as close as possible to the intersection of the scan centreline and the measurement line.

The test piece, or the scanner, shall be capable of being rotated around the rotation axis such that any eccentric motion of the test piece, relative to the scan path, remains in parallel with the scan path and perpendicular to the longitudinal axis of the test piece.

Adjust the instrument and/or feeding and rotational apparatus for the scan path to scan the required section of the test piece.

Operate the apparatus in accordance with the manufacturer's instructions and accurately record the mean, minimum and maximum diameters.

At least 10 test pieces from one sample should normally be used to determine the mean value of the diameter for the sample.

NOTE 1 In practice, laboratories often take a different number of measurements depending on the application of the measurement.

NOTE 2 It is possible to have either a rotation of the laser beam around the object or a rotation of the object in the laser beam.

NOTE 3 Possible sources of error in measurement of diameter are given in annex B.

NOTE 4 When using old laser beam measuring apparatus, an effect of the roughness of the surface on the measured diameter has been observed (porous plug wrap), which may distort the results by a slight excess.

8 Expression of results

The value of the sample mean diameter shall be the mean value of the individual measurements. See 7.3.

The diameter of individual samples (of rod-like test pieces with a nearly circular cross-section) shall be expressed in millimetres to the nearest 0,01 mm.

The results shall be expressed as follows:

- a) diameter, the arithmetic average of at least 100 individual readings scans, is expressed in millimetres to the nearest 0,01 mm;
- b) sample mean diameter, the average of x diameter measurements (x is normally 10 but may vary; see note 1 in 7.3), is expressed in millimetres to the nearest 0,001 mm;
- c) sample maximum diameter, the maximum diameter obtained from a sample of x test pieces, is expressed in millimetres to the nearest 0,01 mm;

- d) sample minimum diameter, the minimum diameter obtained from a sample of x test pieces, is expressed in millimetres to the nearest 0,01 mm;
- e) absolute ovality is expressed in millimetres to the nearest 0,01 mm;
- f) relative ovality is expressed as a percentage to the nearest 0,1 %.

9 Precision

9.1 Interlaboratory test

An international collaborative study involving eight laboratories was conducted in 1990 on matched samples (filter rods, metal rods, cigarettes) of diameter approximately 7,9 mm, and gave the following values for repeatability limit (r) and reproducibility limit (R).

9.2 Repeatability

The difference between two single results found on matched cigarettes or filter-rod samples, by one operator using the same apparatus within the shortest feasible time interval, will exceed the repeatability limit (r) on average not more than once in 20 cases in the normal and correct operation of the method.

Single measurements: $r = 0,028$ mm
 $s_r = 0,01$ mm

Mean values from 10 repeated measurements
per sample (on one day of test): $r = 0,012$ mm
 $s_r = 0,0042$ mm

iTeh STANDARD PREVIEW
(standards.iteh.ai)

[SIST ISO 2971:1998](https://standards.iteh.ai/catalog/standards/sist/87e3216d-3399-4bba-af70-aa2828e2f7f5/sist-iso-2971-1998)

9.3 Reproducibility

Single results on matched cigarettes or filter-rod samples reported by two laboratories will differ by more than the reproducibility limit (R) on average not more than once in 20 cases in the normal and correct operation of the method.

Single measurements: $R = 0,042$ mm
 $s_R = 0,015$ mm

Mean values from 10 repeated measurements
per sample (on one day of test): $R = 0,038$ mm
 $s_R = 0,014$ mm

10 Test report

The test report shall indicate the method used and the results obtained. It shall also mention any operating conditions not specified in this International Standard, or regarded as optional, as well as any circumstances that may have influenced the results.

The test report shall include all details required for complete identification of the sample.

Specifically the test report shall contain:

- a) date of sampling and sampling method;
- b) identification and full description of the samples tested, stating the properties (nature, size) of samples;
- c) date of measurement;