



# SLOVENSKI STANDARD

## SIST EN 14833:2005

01-september-2005

---

BUZb] ]b'gcf cXb] dfc]nj cX] È8 c`c Ub^Y\ ]Xfc` ]rg\_Y'ghUV] bcgh] Zc gZ hYghYfb] hY\_c ]bžcXdcfb] `dfc]c[ b1

Petroleum and related products - Determination of the hydrolytic stability of fire-resistant phosphate ester fluids

Mineralölerzeugnisse und verwandte Produkte - Bestimmung der hydrolytischen Stabilität von schwerentflammbaren Flüssigkeiten auf der Basis von Phosphorsäureestern

[SIST EN 14833:2005](https://standards.iteh.ai/catalog/standards/sist/c1401aca-70e0-4f12-8e3f-45516b507dab/sist-en-14833-2005)

Pétrole et produits connexes - Détermination de la résistance à l'hydrolyse des fluides difficilement inflammables à base d'esters phosphates

Ta slovenski standard je istoveten z: EN 14833:2005

---

### ICS:

75.080 Naftni proizvodi na splošno Petroleum products in general

SIST EN 14833:2005

en

**iTeh STANDARD PREVIEW**  
**(standards.iteh.ai)**

SIST EN 14833:2005

<https://standards.iteh.ai/catalog/standards/sist/c1401aca-70e0-4f12-8e3f-45310f967dab/sist-en-14833-2005>

EUROPEAN STANDARD

EN 14833

NORME EUROPÉENNE

EUROPÄISCHE NORM

June 2005

ICS 75.080

English version

## Petroleum and related products - Determination of the hydrolytic stability of fire-resistant phosphate ester fluids

Pétrole et produits connexes - Détermination de la résistance à l'hydrolyse des fluides difficilement inflammables à base d'esters phosphates

Mineralölerzeugnisse und verwandte Produkte - Bestimmung der hydrolytischen Stabilität von schwerentflammbaren Flüssigkeiten auf der Basis von Phosphorsäureestern

This European Standard was approved by CEN on 25 May 2005.

CEN members are bound to comply with the CEN/CENELEC Internal Regulations which stipulate the conditions for giving this European Standard the status of a national standard without any alteration. Up-to-date lists and bibliographical references concerning such national standards may be obtained on application to the Central Secretariat or to any CEN member.

This European Standard exists in three official versions (English, French, German). A version in any other language made by translation under the responsibility of a CEN member into its own language and notified to the Central Secretariat has the same status as the official versions.

CEN members are the national standards bodies of Austria, Belgium, Cyprus, Czech Republic, Denmark, Estonia, Finland, France, Germany, Greece, Hungary, Iceland, Ireland, Italy, Latvia, Lithuania, Luxembourg, Malta, Netherlands, Norway, Poland, Portugal, Slovakia, Slovenia, Spain, Sweden, Switzerland and United Kingdom.

<https://standards.iteh.ai/catalog/standards/sist/c1401aca-70e0-4f12-8e3f-45310f967dab/sist-en-14833-2005>



EUROPEAN COMMITTEE FOR STANDARDIZATION  
COMITÉ EUROPÉEN DE NORMALISATION  
EUROPÄISCHES KOMITEE FÜR NORMUNG

Management Centre: rue de Stassart, 36 B-1050 Brussels

## Contents

	Page
Foreword .....	3
1 Scope .....	4
2 Normative references .....	4
3 Terms and definitions .....	4
4 Principle .....	5
5 Reagents and materials .....	5
6 Apparatus .....	5
7 Samples and sampling .....	6
8 Preparation of glassware .....	7
9 Procedure .....	7
10 Calculation .....	7
11 Expression of results .....	8
12 Precision .....	8
13 Test report .....	8
Bibliography .....	9

[SIST EN 14833:2005](https://standards.iteh.ai/catalog/standards/sist/c1401aca-70e0-4f12-8e3f-45310f967dab/sist-en-14833-2005)  
<https://standards.iteh.ai/catalog/standards/sist/c1401aca-70e0-4f12-8e3f-45310f967dab/sist-en-14833-2005>

## Foreword

This European Standard (EN 14833:2005) has been prepared by Technical Committee CEN/TC 19 “Petroleum products, lubricants and related products”, the secretariat of which is held by NEN.

This European Standard shall be given the status of a national standard, either by publication of an identical text or by endorsement, at the latest by December 2005, and conflicting national standards shall be withdrawn at the latest by December 2005.

According to the CEN/CENELEC Internal Regulations, the national standards organizations of the following countries are bound to implement this European Standard: Austria, Belgium, Cyprus, Czech Republic, Denmark, Estonia, Finland, France, Germany, Greece, Hungary, Iceland, Ireland, Italy, Latvia, Lithuania, Luxembourg, Malta, Netherlands, Norway, Poland, Portugal, Slovakia, Slovenia, Spain, Sweden, Switzerland and United Kingdom.

## iTeh STANDARD PREVIEW (standards.iteh.ai)

[SIST EN 14833:2005](https://standards.iteh.ai/catalog/standards/sist/c1401aca-70e0-4f12-8e3f-45310f967dab/sist-en-14833-2005)

<https://standards.iteh.ai/catalog/standards/sist/c1401aca-70e0-4f12-8e3f-45310f967dab/sist-en-14833-2005>

## 1 Scope

This European Standard specifies a method for the determination of the hydrolytic stability of phosphate ester fire-resistant hydraulic fluids. These fluids fall under category HFDR of EN ISO 6743-4 [2] and categories TSD, TGD and TCD of ISO 6743-5 [3].

Hydrolysis results in the formation of acid, measurement of which is effected by using one of the test methods ISO 6618, ISO 6619 or ISO 7537. Results from two different test methods are not necessarily compatible and direct comparison needs caution.

The method is applicable to hydrolytic stability results of up to 0,50 mg KOH/g.

NOTE This test may also be applied to other non-aqueous fire-resistant fluids, such as those falling into category HFDU of EN ISO 6743-4 [2].

**WARNING — The use of this European Standard may involve hazardous materials, operations and equipment. This document does not purport to address all of the safety problems associated with its use. It is the responsibility of the user of this document to establish appropriate safety and health practices and determine the applicability of regulatory limitations prior to use.**

## 2 Normative references

The following referenced documents are indispensable for the application of this document. For dated references, only the edition cited applies. For undated references, the latest edition of the referenced document (including any amendments) applies.

EN ISO 3170, *Petroleum liquids — Manual sampling (ISO 3170:2004)*

EN ISO 3696, *Water for analytical laboratory use — Specification and test methods (ISO 3696:1987)*

ISO 6618, *Petroleum products and lubricants — Determination of acid or base number — Colour-indicator titration method*

ISO 6619, *Petroleum products and lubricants — Neutralization number — Potentiometric titration method*

ISO 7537, *Petroleum products — Determination of acid number — Semi-micro colour-indicator titration method*

## 3 Terms and definitions

For the purposes of this European Standard, the following terms and definitions apply.

### 3.1

#### hydrolytic stability

sum of the changes in acid number of a fire-resistant fluid and in acid number of water when contacted for 96 h under the conditions of this document

## 4 Principle

The sample is hydrolysed with water in the ratio 3:1 for 96 h at 85 °C. Special attention is given to the fact that this static test is performed without stirring. The acid number of both fluid and water phases is determined before and after the period, and the sum of the increases recorded as the hydrolytic stability.

## 5 Reagents and materials

**5.1 Water**, conforming to grade 3 of EN ISO 3696.

## 6 Apparatus

### 6.1 General

Tapered ground-glass and vapour-tight joints specified for the glassware in this document shall be either 29/32 or 29/43. It is important that whichever series is chosen, the male and female joints are of the same length.

A general schematic diagram of the apparatus is given in Figure 1.

**6.2 Balance**, with a capacity of 1 kg minimum, capable of weighing to the nearest 0,1 g or better.

**6.3 Flask**, constructed from borosilicate glass, conical, 500 ml capacity and fitted with a female tapered ground-glass joint.

### 6.4 Adaptors

**6.4.1 Two-neck adaptor**, fitted with a male tapered ground-glass joint at the bottom and with parallel necks each fitted with a female tapered ground-glass joint.

**6.4.2 Joint adaptor**, with a male tapered ground-glass joint at the bottom and screwed connecting caps to hold the temperature sensor (6.7).

**6.5 Condenser**, of the jacketed-coil type, fitted with a male tapered ground-glass joint at the bottom end and a female tapered ground-glass joint at the other, with a minimum length of 250 mm, and supplied with a polytetrafluoroethylene (PTFE) collar and a polyethylene stopper fitting the female joint.

**6.6 Oil bath**, fitted with variable temperature control in the range 85 °C to 95 °C and of sufficient depth to immerse the flask (6.3) in the liquid up to the neck without resting on the bottom.

NOTE A suitable holder suspended from the top of the bath giving the specified immersion, is recommended.

**6.7 Temperature sensor**, a liquid-in-glass total immersion thermometer of nominal range 0 °C to 100 °C, readable to 0,2 °C or better, or a temperature measurement device or system of at least equivalent accuracy.

**6.8 Separating funnel**, stoppered funnel of 500 ml capacity.

**6.9 Oven**, controlled at 105 °C ± 5 °C for drying glassware.

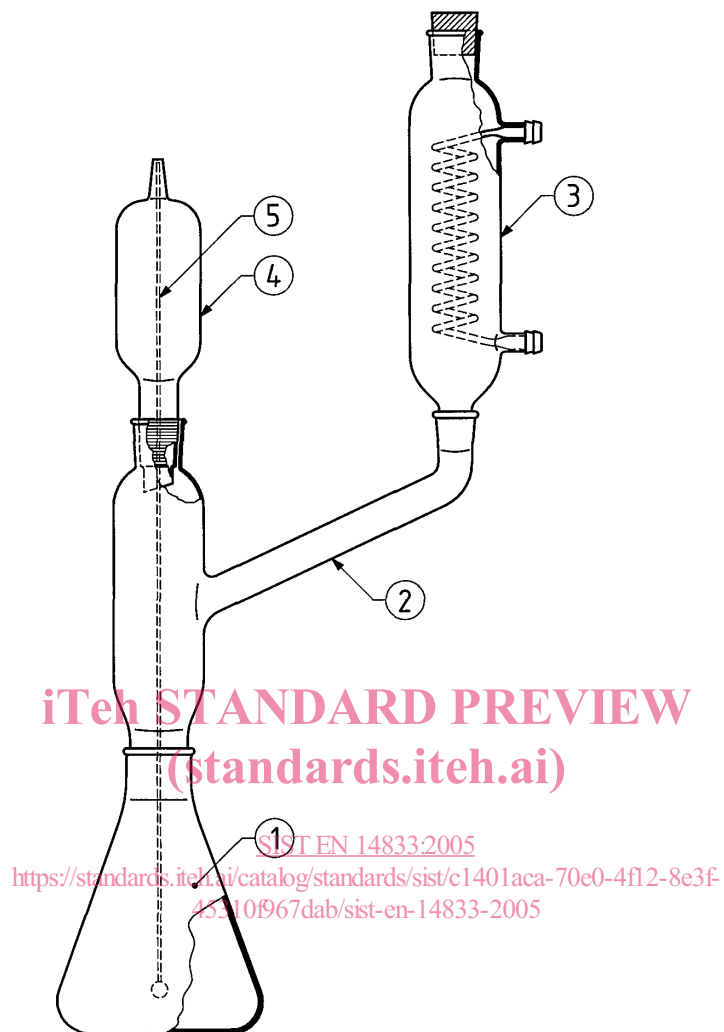
**Key**

- |   |                              |   |                          |
|---|------------------------------|---|--------------------------|
| 1 | Conical Flask (6.3)          | 4 | Joint adaptor (6.4.2)    |
| 2 | Two neck adaptor (6.4.1)     | 5 | Temperature sensor (6.7) |
| 3 | Condenser with stopper (6.5) |   |                          |

**Figure 1 — Schematic drawing of the test apparatus**

## 7 Samples and sampling

**7.1** Unless otherwise specified, samples shall be taken as described in EN ISO 3170 and/or in accordance with the requirements of national standards or regulations for the sampling of the product under test.

**7.2** The test portion shall be clear and bright. The presence of any sediment or free or dispersed water shall be noted in the test report and removed by filtration or decantation prior to testing.



## 8 Preparation of glassware

Ensure that the glassware is clean and dry before use. Use suitable solvents and non-ionic detergents for preliminary cleaning, followed by thorough rinsing with water (5.1). Dry in the oven (6.9) for 30 min and allow to cool in a covered vessel.

## 9 Procedure

**9.1** Determine the acid number of the sample and the acid number of the water (5.1) in accordance with the titration procedure specified in ISO 6618, ISO 6619 or ISO 7537.

**9.2** Weigh the flask (6.3) to the nearest 0,1 g.

**9.3** Add 300 g  $\pm$  0,1 g of sample to the flask (6.3), followed by 100 g  $\pm$  0,1 g of the water (5.1). Record the total mass.

**9.4** Fit the PTFE collar to the curved part of the two-neck adaptor (6.4.1), and then fit the condenser (6.5).

**9.5** Fit the joint adaptor (6.4.2) to the straight-through part of the two-neck adaptor, and insert the temperature sensor to a depth so that the bottom of the bulb or sensing device is 10 mm  $\pm$  1 mm from the bottom of the flask.

**9.6** Fit the stopper in the condenser, and switch on the cooling water.

**9.7** Place the assembled apparatus in the bath (6.6) up to the bottom of the neck of the flask (see NOTE under 6.6). The bath shall be controlled at a temperature that maintains the test portion plus water at a temperature of 85 °C  $\pm$  1 °C. Note the time when the temperature of the liquid in the flask reaches 84 °C as the start of the test.

SIST EN 14833:2005

NOTE The appropriate temperature should be determined by preliminary trials, and will be dependent on the bath design, capacity and loading. Normally, it will be in the range 88 °C to 95 °C.

**9.8** After 96 h  $\pm$  1 h, remove the apparatus from the bath and allow the mixture of test portion and water to cool to room temperature.

**9.9** Disassemble the apparatus and clean and dry the outside surface of the flask. Weigh, and add water (5.1) if necessary to match the total mass recorded in 9.3 to  $\pm$  0,1 g.

**9.10** Transfer the mixture of test portion and water from the flask (6.3) to the separating funnel (6.8) and wait until separation is complete. If separation is not complete in 50 min, but sufficient clear liquid is available in each phase to complete 9.11, carry out the procedure given in 9.11. If insufficient clear liquid is available in either phase, leave for up to an additional 1 h and take a test portion from each phase as soon as sufficient clear liquid is available. Report the result as "late". If, after 1 h 50 min, there is still insufficient phase separation, report the result as "unobtainable".

**9.11** Remove a test portion from each of the two phases and determine the acid number in accordance the selected titration method (see Clause 1).

## 10 Calculation

Calculate the hydrolytic stability, *HS*, expressed in milligrams of KOH per gram, as the sum of the differences in acid number of sample and water before and after thermal stress, using: