**Textiles — Seam tensile properties of
fabrics and made-up textile articles —**

Part 2:

Determination of maximum force to seam
rupture using the grab method

iTeh STANDARD PREVIEW

*Textiles — Propriétés de résistance à la traction des coutures d'étoffes et
d'articles textiles confectionnés*

*Partie 2: Détermination de la force maximale avant rupture des coutures
par la méthode d'arrachement (Grab test)*

<https://standards.iteh.ai/catalog/standards/sist/7c792db4-36e3-44e4-8aa6-85417e89abe3/iso-13935-2-1999>



Foreword

ISO (the International Organization for Standardization) is a worldwide federation of national standards bodies (ISO member bodies). The work of preparing International Standards is normally carried out through ISO technical committees. Each member body interested in a subject for which a technical committee has been established has the right to be represented on that committee. International organizations, governmental and non-governmental, in liaison with ISO, also take part in the work. ISO collaborates closely with the International Electrotechnical Commission (IEC) on all matters of electrotechnical standardization.

International Standards are drafted in accordance with the rules given in the ISO/IEC Directives, Part 3.

Draft International Standards adopted by the technical committees are circulated to the member bodies for voting. Publication as an International Standard requires approval by at least 75 % of the member bodies casting a vote.

Attention is drawn to the possibility that some of the elements of this part of ISO 13935 may be the subject of patent rights. ISO shall not be held responsible for identifying any or all such patent rights.

International Standard ISO 13935-2 was prepared by the European Committee for Standardization (CEN) in collaboration with ISO Technical Committee TC 38, *Textiles*, in accordance with the Agreement on technical cooperation between ISO and CEN (Vienna Agreement).

Throughout the text of this standard, read “..this European Standard...” to mean “...this International Standard...”.

ISO 13935 consists of the following parts, under the general title *Textiles — Seam tensile properties of fabrics and made-up textile articles*:

- *Part 1: Determination of maximum force to seam rupture using the strip method*
- *Part 2: Determination of maximum force to seam rupture using the grab method*

Annexes A and B of this part of ISO 13935 are for information only.

© ISO 1999

All rights reserved. Unless otherwise specified, no part of this publication may be reproduced or utilized in any form or by any means, electronic or mechanical, including photocopying and microfilm, without permission in writing from the publisher.

International Organization for Standardization
Case postale 56 • CH-1211 Genève 20 • Switzerland
Internet iso@iso.ch

Printed in Switzerland

Contents

Foreword	iv
Introduction	iv
1 Scope	1
2 Normative References	1
3 Definitions	1
4 Principle	2
5 Sampling	2
6 Apparatus	2
7 Atmosphere for conditioning and testing	3
8 Preparation of seams and of test specimens	3
9 Procedure	5
10 Calculation and expression of results	6
11 Test report	6
Annex A (informative) Arrangements of jaws for grab test	7
Annex B (informative) Bibliography	8

iTeh STANDARD PREVIEW
(standards.iteh.ai)

[ISO 13935-2:1999](https://standards.iteh.ai/catalog/standards/sist/7c792db4-36e3-44e4-8aa6-85417e89abe3/iso-13935-2-1999)

<https://standards.iteh.ai/catalog/standards/sist/7c792db4-36e3-44e4-8aa6-85417e89abe3/iso-13935-2-1999>

Foreword

The text of EN ISO 13935-2:1999 has been prepared by Technical Committee CEN/TC 248 "Textiles and textile products", the secretariat of which is held by BSI, in collaboration with Technical Committee ISO/TC 38 "Textiles".

This European Standard shall be given the status of a national standard, either by publication of an identical text or by endorsement, at the latest by August 1999, and conflicting national standards shall be withdrawn at the latest by August 1999.

According to the CEN/CENELEC Internal Regulations, the national standards organizations of the following countries are bound to implement this European Standard: Austria, Belgium, Czech Republic, Denmark, Finland, France, Germany, Greece, Iceland, Ireland, Italy, Luxembourg, Netherlands, Norway, Portugal, Spain, Sweden, Switzerland and the United Kingdom.

Introduction

This part of EN ISO 13935 has been prepared in the context of several test methods for determination of certain mechanical properties of textiles using mainly tensile testing machines, e.g. tensile properties, seam tensile properties, tear properties, seam slippage. The procedure for these standards agree where appropriate. The results obtained by one of the methods should not be compared with those obtained by the other methods. See annex B for informative references.

EN ISO 13935 consists of the following parts, under the general title Textiles - Seam tensile properties of fabrics and made-up textile articles:

- Part 1: Determination of maximum force to seam rupture using the strip method
- Part 2: Determination of maximum force to seam rupture using the grab method

<https://standards.iteh.ai/catalog/standards/sist/7c792db4-36e3-44e4-8aa6-85417e89abe3/iso-13935-2-1999>

Annexes A and B of this part of EN ISO 13935 are for information only.

Where it is intended to compare the seam maximum force values of sewn seams with the fabric maximum force, it is important to use the same type of test, test conditions and test specimens in the tests in this standard and EN ISO 13934-2 (see annex B).

1 Scope

This part of EN ISO 13935 specifies methods for the determination of seam maximum force of sewn seams when the force is applied perpendicularly to the seam. This part of EN ISO 13935 describes the method known as the grab test.

Note : Part 1 of EN ISO 13935 describes the method known as the strip test. For informative references see annex B.

The method is mainly applicable to woven textile fabrics. It may be applicable to fabrics produced by other techniques. It is not normally applicable to woven elastic fabrics, geotextiles, nonwovens, coated fabrics, textile-glass woven fabrics and fabrics made from carbon fibres or polyolefin tape yarns (see annex B).

The sewn fabrics may be obtained from previously sewn articles or may be prepared from fabric samples, as agreed by the parties interested in the results.

This method is applicable to straight seams only and not to curved seams.

The method is restricted to the use of constant rate of extension (CRE) testing machines.

2 Normative references

The following standards contain provisions which, through reference in this text, constitute provisions of this International Standard. At the time of publication, the editions indicated were valid. All standards are subject to revision, and parties to agreements based on this International Standard are encouraged to investigate the possibility of applying the most recent editions of the standards indicated below. Members of IEC and ISO maintain registers of currently valid International Standards.

EN 20139	Textiles - Standard atmospheres for conditioning and testing (ISO 139:1973) https://standards.iteh.ai/catalog/standards/sist/7c792db4-36e3-44e4-8aa6-1a1712057e10/iso-20139
EN 10002-2	Metallic materials - Tensile testing - Part 2: Verification of the force measuring system of the tensile testing machines
EN 30012-1	Quality assurance requirements for measuring equipment - Part 1: Metrological confirmation system for measuring equipment (ISO 10012-1:1992)

3 Definitions

For the purposes of this part of EN ISO 13935 the following definitions apply:

3.1 Constant-rate-of-extension (CRE) testing machine

Tensile-testing machine provided with one clamp which is stationary and another clamp which moves with a constant speed throughout the test, the entire testing system being virtually free from deflection (EN ISO 13934-1).

3.2 Grab test

Tensile test in which only the centre part of the test specimen is gripped in the jaws of the testing machine (EN ISO 13934-2).

3.3 Maximum force at seam rupture

Maximum force recorded when a test specimen with a seam perpendicular to the direction of extension is taken to seam rupture during a tensile test under the specified conditions (EN ISO 13935-1).

3.4 Gauge length

Distance between the two effective clamping points of a testing device (EN ISO 13934-1).

Note : The effective clamping points (or lines) of jaws can be checked by clamping a test specimen under defined pretension with carbon copy paper to produce a gripping pattern on the test specimen and/or the jaw faces (EN ISO 13934-1).

4 Principle

A fabric test specimen having a seam in the middle is gripped in its centre part by jaws of specified dimensions and is extended perpendicularly to the seam at a constant rate until the seam ruptures. The maximum force to seam rupture is recorded.

5 Sampling

Select samples either in accordance with the procedure laid down in the material specification for the fabric, or as agreed between the interested parties.

If preparation of seams prior to testing is required, avoid test specimens from folded or creased areas, selvages and areas not representative of the fabric.

For seams obtained from previously sewn articles ensure that the test specimens contain seams in straight line only and are representative for the relevant seam type of the textile article. Record any details in the test report.

IT IS STANDARD PREVIEW
(standards.iteh.ai)

[ISO 13935-2:1999](https://standards.iteh.ai/catalog/standards/sist/7c792db4-36e3-44e4-8aa6-85417e89abe3/iso-13935-2-1999)

6 Apparatus

<https://standards.iteh.ai/catalog/standards/sist/7c792db4-36e3-44e4-8aa6-85417e89abe3/iso-13935-2-1999>

6.1 CRE machine.

Metrological confirmation system of the tensile-testing machine shall be in accordance with EN 30012-1.

The constant-rate-of-extension (CRE) machine shall have the general characteristics given in 6.1.1 to 6.1.6:

6.1.1 The tensile-testing machine shall be provided with means for indicating or recording the force applied to the test specimen in stretching it to rupture. Under conditions of use, the accuracy of the apparatus shall be class 1 of EN 10002-2. The error of the indicated or recorded maximum force at any point in the range in which the machine is used shall not exceed ± 1 %.

6.1.2 If a class 2 tensile testing machine according to EN 10002-2 is to be used, this shall be stated in the test report.

6.1.3 If recording of force is obtained by means of data acquisition boards and software, the frequency of data collection shall be at least eight per second.

6.1.4 The machine shall be capable of constant rate of extension of 50 mm/min, with an accuracy of ± 10 %.

6.1.5 The machine shall be capable of setting the gauge length to 100 mm, to within ± 1 mm.

6.1.6 The clamping device of the machine shall be positioned with the central point of the two jaws in the line of applied force, the front edges shall be at right angles to the line of applied force and their clamping faces shall be in the same plane.

The jaws shall be capable of holding the test specimen without allowing it to slip and designed so that they do not cut or otherwise weaken the test specimen.

The faces of the jaws shall be smooth and flat, except that when, even with packing, the test specimen cannot be held satisfactorily with flat-faced jaws, engraved or corrugated jaws can be used to prevent slippage. Other auxiliary materials for use with either smooth or corrugated jaws to improve specimen gripping include paper, leather, plastics or rubber.

For the grab test the dimensional clamping area of the fabric shall be $(25 \text{ mm} \pm 1 \text{ mm}) \times (25 \text{ mm} \pm 1 \text{ mm})$. This area can be achieved by either the method given in a) or b) and illustrated in annex A.

a) One clamp (25 mm) x (40 mm min., preferably 50 mm), positioned with the wider direction of the clamp perpendicular to the line of application of the force; a second clamp of the same dimensions positioned perpendicular to the first so that the wider direction of the clamp is parallel to the direction of application of the force.

b) One clamp (25 mm) x (40 mm min., preferably 50 mm), positioned with the wider direction of the clamp perpendicular to the line of application of the force; a second clamp (25 mm) x(25 mm).

6.2 Equipment for sewing defined seams.

6.3 Equipment for cutting test specimens.

iTeh STANDARD PREVIEW
(standards.iteh.ai)

7 Atmosphere for conditioning and testing [ISO 13935-2:1999](#)

<https://standards.iteh.ai/catalog/standards/sist/7c792db4-36e3-44e4-8aa6->

The atmospheres for preconditioning, conditioning and testing shall be as specified in EN 20139.

Note : It is recommended that samples be conditioned for at least 24 h in the relaxed state.

8 Preparation of seams and of test specimens

8.1 Preparation of seams, if required, before testing.

Where the seams are to be prepared for testing, the interested parties shall agree on the conditions of sewing, including type of sewing threads, type of needle, type of seam, seam allowance and number of stitches per unit length. The sewing machine shall be adjusted to give the correct conditions, using a spare piece of the fabric for testing.

Cut a sample of the fabric 250 mm by at least 700 mm.

Fold the sample in half with the fold parallel to the longer dimension, make the agreed seam in this direction, and cut to give the agreed seam allowance. Seams may be sewn for testing parallel to the warp or weft direction, or both, as agreed between the interested parties.

8.2 Dimensions

From each laboratory sample with seams cut a set of at least five test specimens of width 100 mm, as shown in figure 1.

Dimensions in mm.

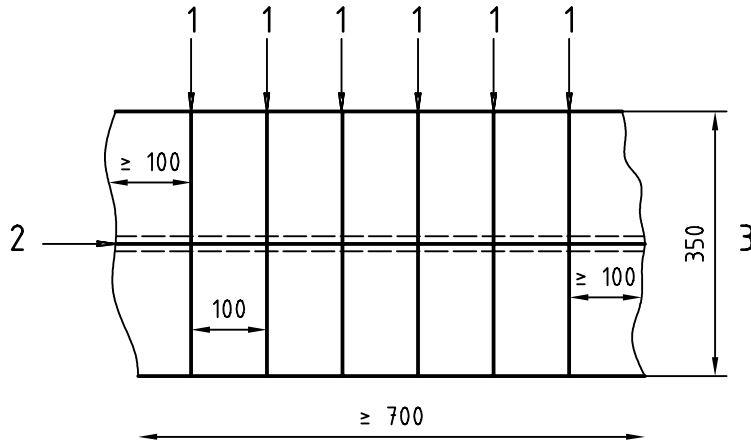

- 1. Cut
- 2. Seam
- 3. Length before seaming

iTeh STANDARD PREVIEW
(standards.iteh.ai)

Figure 1 laboratory sample with seams and indication of test specimens

When using seams prepared as described in 8.1, do not cut samples within 100 mm of either end of the prepared seam (see figure 1).
<https://standards.iteh.ai/catalog/standards/sist/7c792db4-36e3-44e4-8aa6-85417e89abe3/iso-13935-2-1999>

8.3 Preparation of test specimens

On each test specimen a line shall be drawn at a distance of 38 mm from one edge running the full length of the test specimen (see figure 2).

Dimensions in mm.

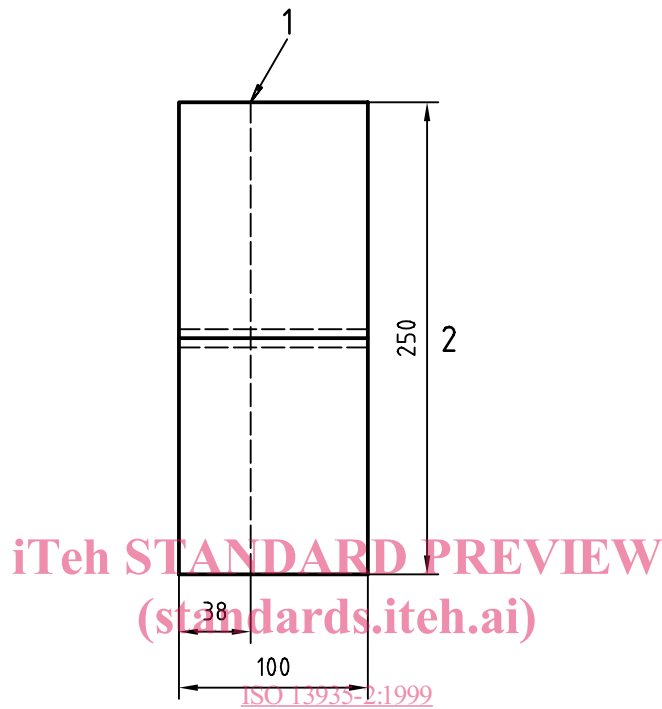

<https://standards.iteh.ai/catalog/standards/sist/7c792db4-36e3-44e4-8aa6-85417e89abe3/iso-13935-2-1999>

1. Drawn line
2. Length before seaming

Figure 2 Test specimen ready for testing

9 Procedure

9.1 Gauge length

Set the gauge length of the tensile-testing machine to 100 mm \pm 1 mm.

9.2 Rate of extension

Set the rate of extension of the tensile-testing machine to 50 mm/min.

9.3 Mounting of test specimens

Clamp a test specimen centrally so that its longitudinal centre line passes through the centre point of the front edges of the jaws and is perpendicular to the edges of the jaws and so that the line drawn on the test specimen coincides with one edge of the jaws and the force is applied perpendicularly to the seam in the middle of the gauge length.

After closing the upper jaw, avoid pretension when adjusting the test specimen along the guide line in the lower jaw, so that the fabric hangs under its own weight when the lower clamp is closed.