

---

---

**Non-destructive testing — Acoustic  
emission inspection — Primary calibration  
of transducers**

*Essais non destructifs — Contrôle par émission acoustique — Étalonnage  
primaire des transducteurs*

**iTeh STANDARD PREVIEW**  
**(standards.iteh.ai)**

[ISO 12713:1998](https://standards.iteh.ai/catalog/standards/sist/bceaa972-65f9-4efd-9713-b3fc6465a2fb/iso-12713-1998)

[https://standards.iteh.ai/catalog/standards/sist/bceaa972-65f9-4efd-9713-  
b3fc6465a2fb/iso-12713-1998](https://standards.iteh.ai/catalog/standards/sist/bceaa972-65f9-4efd-9713-b3fc6465a2fb/iso-12713-1998)



## Contents

Page

1	Scope .....	1
2	Normative references .....	1
3	Definitions .....	1
4	Symbols and abbreviation .....	2
5	General requirements .....	2
6	Apparatus .....	4
7	Calibration data processing .....	8
8	Error analysis .....	11
9	Typical calibration results .....	12

### Annex

A	Bibliography .....	24
---	--------------------	----

**iTeh STANDARD PREVIEW**  
**(standards.iteh.ai)**

ISO 12713:1998

<https://standards.iteh.ai/catalog/standards/sist/bceaa972-65f9-4efd-9713-f3fc6465a2fb/iso-12713-1998>

© ISO 1998

All rights reserved. Unless otherwise specified, no part of this publication may be reproduced or utilized in any form or by any means, electronic or mechanical, including photocopying and microfilm, without permission in writing from the publisher.

International Organization for Standardization  
Case postale 56 • CH-1211 Genève 20 • Switzerland  
Internet iso@iso.ch

Printed in Switzerland

## Foreword

ISO (the International Organization for Standardization) is a worldwide federation of national standards bodies (ISO member bodies). The work of preparing International Standards is normally carried out through ISO technical committees. Each member body interested in a subject for which a technical committee has been established has the right to be represented on that committee. International organizations, governmental and non-governmental, in liaison with ISO, also take part in the work. ISO collaborates closely with the International Electrotechnical Commission (IEC) on all matters of electrotechnical standardization.

Draft International Standards adopted by the technical committees are circulated to the member bodies for voting. Publication as an International Standard requires approval by at least 75 % of the member bodies casting a vote.

iTeh STANDARD PREVIEW

International Standard ISO 12713 was prepared by Technical Committee ISO/TC 135, *Non-destructive testing*, Subcommittee SC 3, *Acoustical methods*.

[ISO 12713:1998](#)

<https://standards.iteh.ai/catalog/standards/sist/bfc6465a2fb/iso-12713-1998> Annex A of this International Standard is for information only.

<https://standards.iteh.ai/catalog/standards/sist/bfc6465a2fb/iso-12713-1998>

## Introduction

The acoustic emission method of non-destructive testing is one of the methods addressed by SC 3 on acoustical methods, of TC 135 on non-destructive testing. Standards for general procedures and requirements are required in order to ensure quantitative results and wide applicability. This International Standard addresses one method for the primary calibration of acoustic emission transducers. It is anticipated that as other methods of determining transducer sensitivity and phase response are documented, this International Standard will be appended. This International Standard was first introduced by the USA at the fifth meeting of ISO/TC 135/SC 3 in Berlin, April 1989.

## iTeh STANDARD PREVIEW (standards.iteh.ai)

[ISO 12713:1998](https://standards.iteh.ai/catalog/standards/sist/bceaa972-65f9-4efd-9713-b3fc6465a2fb/iso-12713-1998)

<https://standards.iteh.ai/catalog/standards/sist/bceaa972-65f9-4efd-9713-b3fc6465a2fb/iso-12713-1998>

# Non-destructive testing — Acoustic emission inspection — Primary calibration of transducers

## 1 Scope

This International Standard specifies a method for the absolute calibration of acoustic emission transducers. The aim of this International Standard is to establish uniformity of acoustic emission testing in order to form a basis for data correlation and to provide for the interpretation of results obtained by different laboratories at different times.

An accepted method for the calibration of acoustic emission transducers must be specified to characterize their behaviour.

This International Standard establishes a method for the primary calibration of acoustic emission transducers as receivers of elastic waves at the surface of a solid medium. The calibration yields the frequency response of a transducer to waves of the type normally encountered in acoustic emission work. The transducer voltage response is determined at discrete frequency intervals of approximately 10 kHz up to 1 MHz. The input is a given well-established dynamic displacement of the mounting surface. The units of the calibration are output voltage per unit mechanical input (displacement, velocity or acceleration). This International Standard is applicable to secondary standard transducers and to acoustic emission applications transducers.

## 2 Normative references

The following standards contain provisions which, through reference in this text, constitute provisions of this International Standard. At the time of publication, the editions indicated were valid. All standards are subject to revision, and parties to agreements based on this International Standard are encouraged to investigate the possibility of applying the most recent editions of the standards indicated below. Members of IEC and ISO maintain registers of currently valid International Standards.

ASTM E 114-95, *Ultrasonic Pulse-Echo Straight-Beam Examination by the Contact Method*.

ASTM E 494-95, *Measuring Ultrasonic Velocity in Materials*.

ASTM E 610-82<sup>1)</sup>, *Standard Definitions of Terms Relating to Acoustic Emission*.

ASTM E 650-85(1992)e1, *Mounting Piezoelectric Acoustic Emission Sensors*.

BRECKENRIDGE, F.R. and GREENSPAN, M. *Surface-Wave Displacement: Absolute Measurements Using a Capacitive Transducer*, Journal Acoustic Society of America, Vol. 69, pp.1177-1185.

## 3 Definitions

An ISO glossary of terms used in acoustic emissions is not yet available. In view of this, for the purposes of this International Standard, ASTM E 610 shall be used as a guide.

## 4 Symbols and abbreviation

### 4.1 Symbols

Symbol	Term	Unit
$a$	effective radius of the sensor face	m
$A$	absolute sensitivity of the standard transducer (in units of volts per free motion)	V·m <sup>-1</sup>
$c$	Rayleigh speed	m·s <sup>-1</sup>
$D(f_m)$	complex valued spectral response of the transducer under test	1
$f$	frequency	MHz
$f_m$	$m^{\text{th}}$ frequency	MHz
$j$	subscript 0, 1, 2, . . . , $n - 1$	1
$J_j$	first order Bessel function	1
$k$	circular wave number	m <sup>-1</sup>
$n$	total number of samples in one channel	1
$r_m$	$m^{\text{th}}$ value of the magnitude of $D(f_m)$	1
$s_j$	$j^{\text{th}}$ sample value in the standard channel	V
$S(f_m)$	complex valued spectra of the standard signal	1
$T$	equals $n\Delta t$ and is the total record time	μs
$u_j$	$j^{\text{th}}$ sample value in the unknown channel	V
$U(f_m)$	complex valued spectra of the unknown signal	1
$\Delta t$	sampling time interval	μs
$\theta_m$	$m^{\text{th}}$ value of the phase of $D(f_m)$	1

### 4.2 Abbreviation

AE: acoustic emission

## 5 General requirements

### 5.1 Displacement transducers

This method is applicable for the absolute calibration of normal displacement transducers for use as secondary standards for the calibration of acoustic emission sensors for the purposes of non-destructive evaluation. For this purpose, the transfer standard should be high-fidelity and very stable and understood. If this can be established, the stated accuracy should apply over the full frequency range up to 1 MHz.

NOTE — The stated accuracy applies only if the transfer standard returns to quiescence, following the transient input, before any wave reflected from the boundary of the calibration block returns to the transfer standard ( $\approx 100 \mu\text{s}$ ). For low frequencies with periods of the order of the time window, this condition is problematical to prove.

## 5.2 Acoustic emission sensors

This International Standard is also applicable for the calibration of acoustic emission sensors for use in non-destructive evaluation. Some of these sensors are less stable than devices suitable for a transfer standard. The stated accuracy for such devices applies over a range of 100 kHz to 1 MHz and with less accuracy below 100 kHz.

NOTE — A primary difficulty in any calibration of a mechanical/electrical transduction device is the determination of the mechanical-motion input to the device. Using this calibration procedure the motional input may be determined by two different means — theoretical calculation and measurement with an absolute displacement transducer.

## 5.3 Theoretical calculation

Elasticity theory has been used to calculate the dynamic displacement of the surface of an infinite half-space due to a normal point-force step function in time. The solutions give the displacement of any point on the surface as a function of time, yielding a wave-form for the displacement called the seismic surface pulse.

This calibration method uses a laboratory approximation to this theoretical solution. See [1] and [2] in annex A. The half-space is approximated by a large metal block in the form of a circular cylinder and the point-force step function is closely approximated by the breaking of a glass capillary against the plane surface of the block. The displacement as a function of time shall be calculated for the location of the device under test (on the same surface of the block as the input). This calculation shall be performed using a measured value of the step function force and the elastic constants that are determined by speed of sound measurements on the block.

## 5.4 Absolute displacement measurement

An absolute measurement of the dynamic normal surface displacement of the block is required for this calibration method. The transducer used for this measurement is a standard transducer against which the device under test is compared. The standard transducer shall meet or exceed the performance of the capacitive transducer described by Breckenridge and Greenspan (see clause 2). The important characteristics of the standard transducer include high fidelity, high sensitivity and operating characteristics amenable to theoretical calculation. It shall also present no appreciable dynamic loading to the surface it is measuring.

For a calibration, the standard transducer and the device to be calibrated are both placed on the same surface of the block as the mechanical input and equidistant in opposite directions from it. This guarantees that both experience the same displacement-time history. Comparison of the output of the transfer standard or AE sensor with the output of the standard transducer yields a calibration of the device under test.

This method is also applicable for the calibration of acoustic emission sensors for use in non-destructive evaluation. Some of these sensors are less stable than devices suitable for a transfer standard. The stated accuracy for such devices applies over a range of 100 kHz to 1 MHz and with less accuracy below 100 kHz.

Other relative geometries for this input and transducers are possible, but results from other geometries should only be used to supplement results from the “same surface” geometry. AE waves in structures are most frequently dominated by surface wave phenomena and the calibration should be based on the transducer's response to such waves.

## 5.5 Units for the calibration

An AE sensor responds to motion at its front face. The actual stress and strain at the front face of a mounted sensor depends on the interaction between the mechanical impedance of the sensor (load) and that of the mounting block (driver); neither the stress nor the strain is amenable to direct measurement at this location. However, the free displacement that would occur at the surface of the block in the absence of the sensor can be inferred from either elasticity theory calculations or from measurements made elsewhere on the surface. Since AE sensors are used to monitor motion at a free surface of a structure and interactive effects between sensor and structure are generally of no interest, the free motion is the appropriate input variable. It is required, therefore, that the units of calibration be voltage per unit of free motion, e.g. volts per metre.

## 5.6 Block material

Since the calibration depends on the interaction of the mechanical impedance of the block and that of the AE sensor, a calibration procedure must specify the material of the block. Calibrations performed on blocks of different materials shall yield transducer sensitivity versus frequency curves that are different in shape and in average magnitude. The amount by which such results differ may be very large. For example, a transducer that has been calibrated on a steel block will, if calibrated on a glass or aluminium block, have an average sensitivity that may be from 50 % to 100 % of the value obtained on steel, and will, if calibrated on a polymethyl methacrylate block, have an average sensitivity that may be as little as 3 % of the value obtained on steel. In general, the sensitivity will be less if the block is made of a less rigid or less dense material.

For surface wave calibrations, the Rayleigh speed in the material of the block affects the calibration. For a sensor having a circular aperture (mounting face) with uniform sensitivity over the face, the aperture effect predicts nulls at the zeroes of  $J_1(ka)$ , where  $k = 2\pi f/c$ .

Hence the frequencies at which the nulls occur are dependent upon the Rayleigh speed.

## 6 Apparatus

### 6.1 General

A typical basis scheme for the calibration is shown in figure 1. A glass capillary, B, of diameter about 0,2 mm, is squeezed between the tip of the loading screw, C, and the upper face of the large steel transfer block, A. When the capillary breaks, the sudden release of force is a step function whose rise time is of the order of 0,1  $\mu$ s. The magnitude of the force step is measured by the combination of the PZT disc, D, in the loading screw and a charge amplifier, E, connected to a storage oscilloscope, F. The standard capacitive transducer, G, and the device under test, H are placed equally distant (usually 0,1 m) from the source and in opposite directions from it. It is obvious from the symmetry that the surface displacements would be the same at the two transducer locations if it were not for the loading effects of the transducers. The loading effect of the standard capacitive transducer is negligible and the loading effect of the unknown sensor is part of its calibration.

Voltage transients from the two transducers are recorded simultaneously by digital recorders, I, and the information is stored for processing by the computer, J.

With such a system it is possible to do the necessary comparison between the signal from the unknown sensor and that from the standard transducer or with the displacement wave-form calculated by elasticity theory. A similar result should be obtained either way.



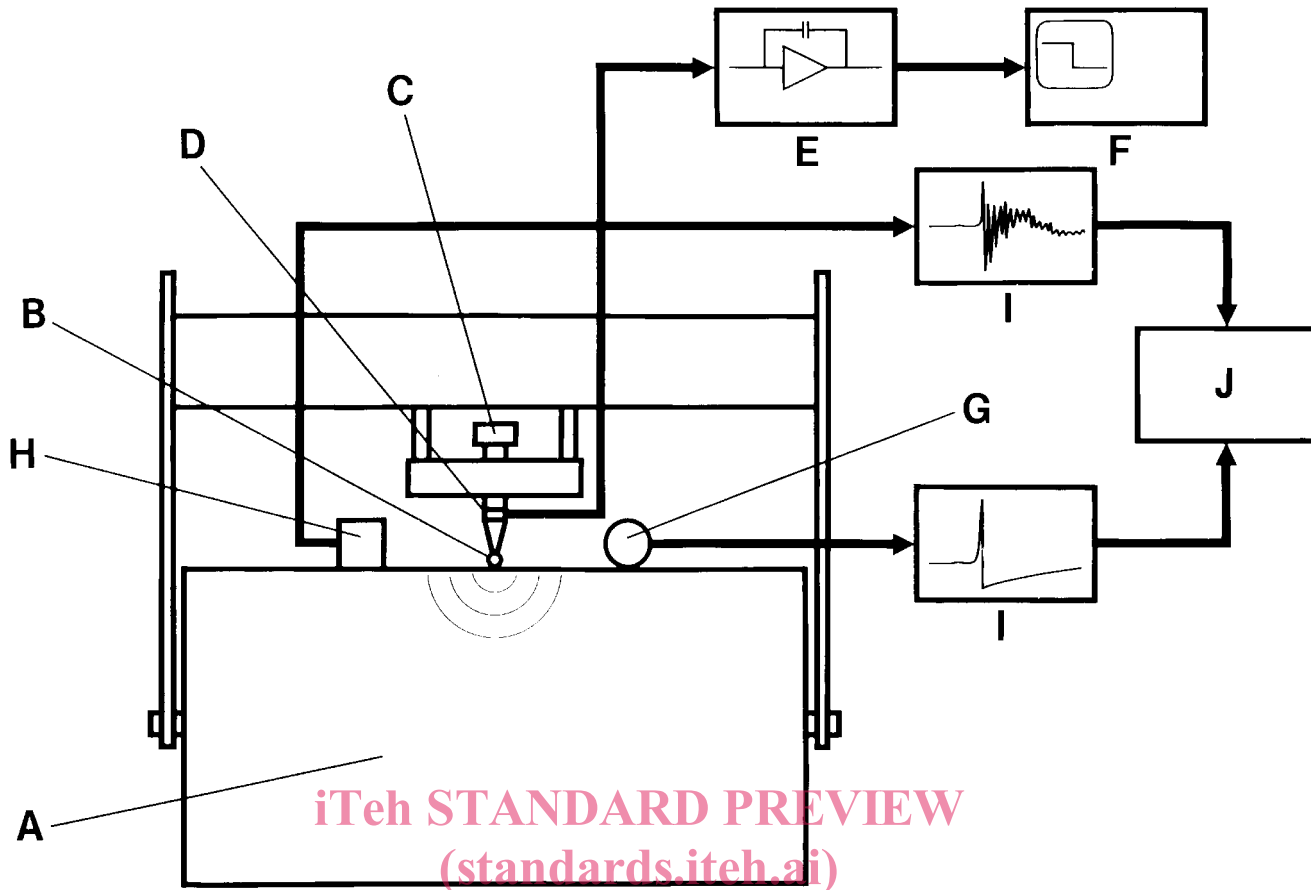

**Key**

- |   |                      |   |                       |
|---|----------------------|---|-----------------------|
| A | Steel transfer block | F | Storage oscilloscope  |
| B | Glass capillary      | G | Standard transducer   |
| C | Loading screw        | H | Transducer under test |
| D | PZD disc             | I | Transient recorder    |
| E | Charge amplifier     | J | Computer              |

**Figure 1 — Schematic diagram of the apparatus**

**6.2 Transfer block**

The transfer block shall be made from specially chosen material. It shall be as defect-free as possible and shall undergo an ultrasonic longitudinal inspection at 2,25 MHz. The method described in ASTM E 114 or equivalent shall be used. The block shall contain no flaws which give a reflection larger than 10 % of the first back wall reflection. The material shall also be highly uniform as determined by pulse-echo time of flight measurements through the block at a minimum of 15 locations regularly spaced over the surface (see ASTM E 494). The individual values of the longitudinal and shear wave speed shall differ from the average by no more than  $\pm 1$  part and  $\pm 3$  parts in  $10^3$ , respectively. A transfer block and calibration apparatus is shown in figure 2.



Figure 2 — Photograph of the steel block with the calibration apparatus in place

### 6.3 Step function source

The step function force events shall be made by breaking glass capillary tubing (see figure 3). The capillaries are drawn down from ordinary laboratory glass tubing made of borosilicate glass. Sizes of the capillary may range from about 0,1 mm to 0,3 mm outside diameter, with 0,2 mm being typical. A bore size equal to the wall thickness gives the best results. The force obtained is usually between 10 N and 30 N, with 20 N being typical.

The capillary shall be laid horizontally on a piece of microscope cover glass (0,08 mm × 1,5 mm × 1,5 mm) which has been cemented to the top face of the steel block with salol (phenyl salicylate) or cyanoacrylate cement. The force is applied to the capillary by a solid glass rod (12 mm in diameter) which has been laid horizontally on top of the capillary and at right angles to it. The rod is forced downward by the loading screw until the capillary breaks. The

loading screw shall contain a ceramic force transducer which has been calibrated by dead weights. Thus, although the size of a source event cannot be predicted in advance, its magnitude may be measured and used for the elasticity theory calculation of the surface displacement.

Ideally, the capillary should rest directly on the steel with no cover glass interposed. It may be found necessary to use the cover slide to prevent damage to the block surface. The presence of the cover glass does alter the waveform very slightly; a slight ringing occurs due to reflections at its boundaries. The ringing contains only frequencies above 2 MHz. Furthermore, the effects on both standard transducer and unknown sensor are the same and therefore the calibration is not affected.

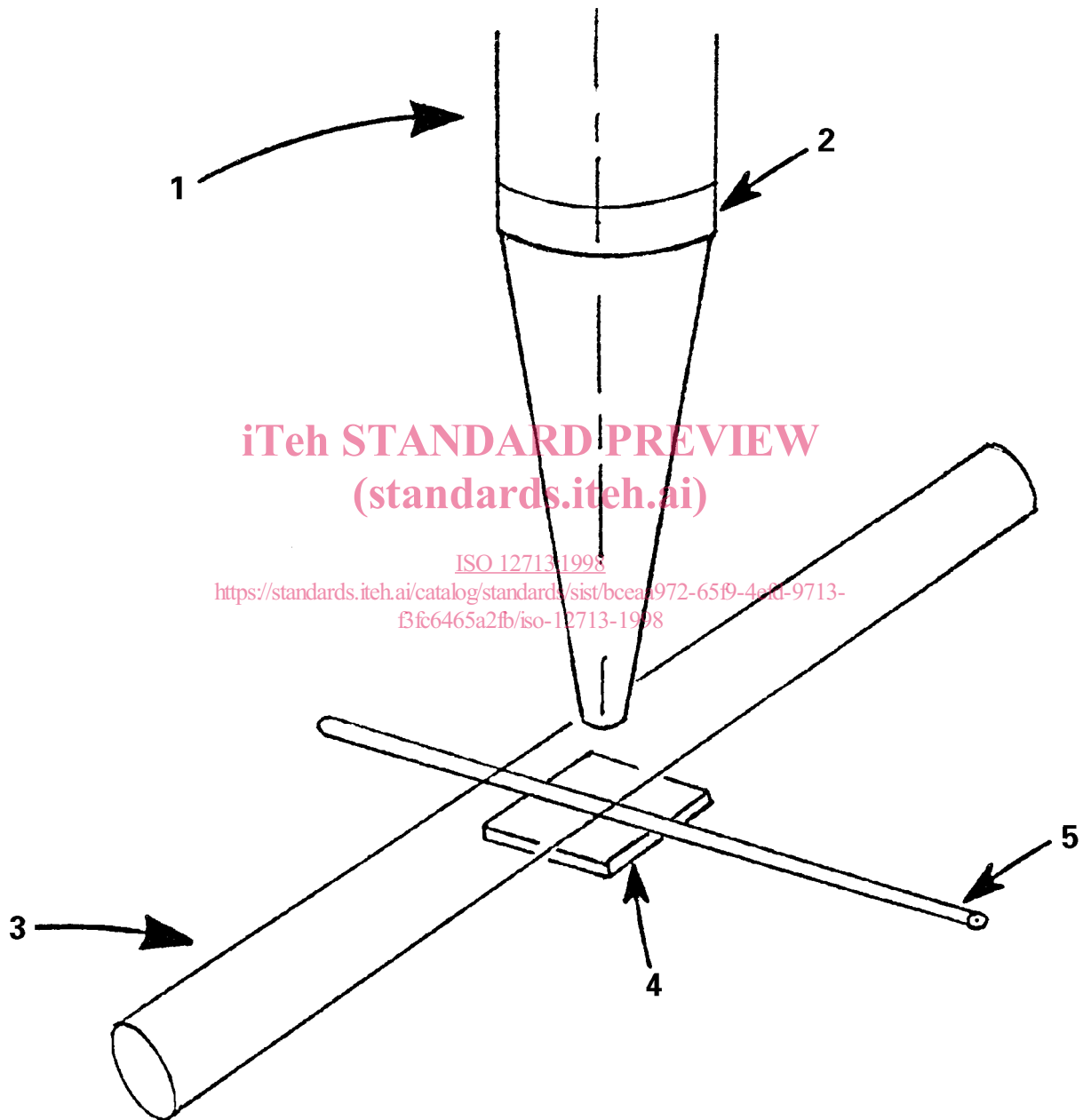
**Key**

- 1 Loading screw
- 2 PZT disc
- 3 Glass rod
- 4 Cover slide
- 5 Capillary

Figure 3 — Glass capillary source

## 6.4 Standard transducer

The standard transducer to be used for the absolute measurement of displacement in the calibration shall have characteristics at least as good as the capacitive transducer described by Breckenridge and Greenspan. This device shown in figures 4a) and 4b), essentially consists of an inertial mass (about 40 g) mounted on compliant supports and separated from the top surface of the steel block by an air gap of about 4  $\mu\text{m}$ . This gap is determined by measuring the capacitance between the transducer and the transfer block using a three-terminal ratio arm bridge as described by Breckenridge and Greenspan. The inertial mass is a brass cylinder with its axis horizontal. When the block surface moves at frequencies above the natural resonance (approximately 1 kHz) of the mass on its compliant supports, the brass cylinder remains approximately stationary. The brass cylinder is d.c. polarized (100 V) through a large-valued resistor so that variation in capacitance results in variation of the voltage on the brass cylinder.

For use as a primary standard, it is essential that the sensitivity of the transducer be calculable. To make the calculations tractable, the cylinder is treated as a section of an infinite cylinder. Electrical guards are attached to each end to eliminate end effect that would otherwise be severe.

The sensing area of the transducer is 12,4 mm long and effectively less than 1 mm wide. The long axis of this area is tangent to an advancing wave-front from the capillary source.

The sensitivity of the transducer is in the neighbourhood of  $12 \times 10^6$  V/m and the minimum, detectable displacement is  $4 \times 10^{-12}$  m. The calculated frequency response of the transducer based on its effective aperture width and its deviation from the curvature of the wave-fronts is shown in figure 5. At 1 MHz the amplitude is down by less than 10 % and the phase lag is about 8°. Equations (4) and (5) can be used to calculate the response at frequencies of interest. The total estimated uncertainty in the displacement measurements is approximately  $\pm 5$  %. Displacement measurements made by the transducer are in agreement with displacements calculated by elasticity theory within 5 %.

iTeh STANDARD PREVIEW

The standard transducer and the device under test shall be placed 0,1 m  $\pm$  1 mm from the source (see ASTM E 650) unless otherwise stated in each report of calibration results.

## 6.5 Data recording and processing equipment

Two synchronized channels of transient recording equipment are necessary for capturing the wave-forms from the standard transducer and the transducer under test. They shall be capable of at least 8 bit accuracy and a sampling rate of 20 MHz or at least 10 bit accuracy and a sampling rate of 10 MHz and shall be capable of at least 102,4  $\mu\text{s}$ . The data so recorded shall be transferred to a minicomputer for data processing and also stored on a permanent device, e.g., floppy disc, as a permanent record.

## 7 Calibration data processing

### 7.1 Notation

The following notation is used to describe the treatment of data to obtain calibration results (see 4.1):

- $n$  is the total number of samples in one channel;
- $\Delta t$  is the sampling time interval in  $\mu\text{s}$ ;
- $T$  is the total record time in  $\mu\text{s}$  ( $= n\Delta t$ );
- $s_j$  is the  $j^{\text{th}}$  sample value in the standard channel;
- $u_j$  is the  $j^{\text{th}}$  sample value in the unknown channel;
- $j = 0, 1, 2, \dots, n - 1$ .

The units of  $s_j$  and  $u_j$  are volts multiplied by an arbitrary constant which depends on the specific electronic equipment figuration.