

# INTERNATIONAL STANDARD

**ISO**  
**12137-2**

First edition  
1997-02-15

---

---

## Paints and varnishes — Determination of mar resistance —

### Part 2: Method using a pointed stylus

*Peinture et vernis — Détermination de la résistance à la détérioration —  
Partie 2: Méthode utilisant un stylet pointu*



Reference number  
ISO 12137-2:1997(E)

## Foreword

ISO (the International Organization for Standardization) is a worldwide federation of national standards bodies (ISO member bodies). The work of preparing International Standards is normally carried out through ISO technical committees. Each member body interested in a subject for which a technical committee has been established has the right to be represented on that committee. International organizations, governmental and non-governmental, in liaison with ISO, also take part in the work. ISO collaborates closely with the International Electrotechnical Commission (IEC) on all matters of electrotechnical standardization.

Draft International Standards adopted by the technical committees are circulated to the member bodies for voting. Publication as an International Standard requires approval by at least 75 % of the member bodies casting a vote.

International Standard ISO 12137-2 was prepared by Technical Committee ISO/TC 35, *Paints and varnishes*, Subcommittee SC 9, *General test methods for paints and varnishes*.

ISO 12137 consists of the following parts, under the general title *Paints and varnishes — Determination of mar resistance*:

- Part 1: *Method using a curved stylus*
- Part 2: *Method using a pointed stylus*

Annex A forms an integral part of this part of ISO 12137. Annex B is for information only.

© ISO 1997

All rights reserved. Unless otherwise specified, no part of this publication may be reproduced or utilized in any form or by any means, electronic or mechanical, including photocopying and microfilm, without permission in writing from the publisher.

International Organization for Standardization  
Case postale 56 • CH-1211 Genève 20 • Switzerland  
Internet central@iso.ch  
X.400 c=ch; a=400net; p=iso; o=isos; s=central

Printed in Switzerland

# Paints and varnishes — Determination of mar resistance —

## Part 2: Method using a pointed stylus

### 1 Scope

**1.1** This part of ISO 12137 is one of a series of standards dealing with the sampling and testing of paints, varnishes and related products.

It specifies a method for determining, using a pointed stylus, the mar resistance of a single coating of a paint, varnish or related product, or the upper layer of a multicoat system. Part 1 of ISO 12137 specifies a method using a curved stylus. The choice between the two methods will depend on the particular practical problem.

<https://standards.iteh.ai/catalog/standards/sist/bd80612d-c2a9-4067-a152-67780b6655e8/iso-12137-2-1997>

**1.2** This test has been found to be useful in comparing the mar resistance of different coatings. It is most useful in providing relative ratings for a series of coated panels exhibiting significant differences in mar resistance.

### 2 Normative references

The following standards contain provisions which, through reference in this text, constitute provisions of this part of ISO 12137. At the time of publication, the editions indicated were valid. All standards are subject to revision, and parties to agreements based on this part of ISO 12137 are encouraged to investigate the possibility of applying the most recent editions of the standards indicated below. Members of IEC and ISO maintain registers of currently valid International Standards.

ISO 1512:1991, *Paints and varnishes — Sampling of products in liquid or paste form.*

ISO 1513:1992, *Paints and varnishes — Examination and preparation of samples for testing.*

ISO 1514:1993, *Paints and varnishes — Standard panels for testing.*

ISO 2808:—<sup>1)</sup>, *Paints and varnishes — Determination of film thickness.*

---

1) To be published. (Revision of ISO 2808:1991)

### 3 Definition

For the purposes of this part of ISO 12137, the following definition applies:

**3.1 mar resistance:** The resistance of the surface of a paint film to marking or the formation of other defects as a result of the action of a specified stylus pushed across the surface.

Marring covers a very broad range of defects in the surface of the paint film. These defects include small scratches and other marks in the surface of the paint film caused by finger nails or car wash brushes, for instance.

The defects are defined as follows:

- a) Plastic deformation — the permanent indentation of the surface with or without any surface blemish or cohesive fracture.
- b) Surface blemish — a superficial surface effect caused by a difference in the scattering of light between the line of test and the adjacent surface.
- c) Surface scratch — a continuous cut or gouge through the surface.
- d) Cohesive fracture — the presence of a visible surface break or rupture.
- e) Combinations of the above.

NOTE — In some cases, one of these types of defect will be of particular importance, while in other cases one of the other types of defect may be of interest.

iTeh STANDARD PREVIEW  
(standards.iteh.ai)

### 4 Principle

The product or system under test is applied at uniform thickness to flat panels of uniform surface texture. After drying/curing, the mar resistance is determined using an automatic tester which pushes the panels beneath a pointed stylus mounted so that it presses down perpendicularly on the surface of the test panel. The load on the test panel is increased continuously until the coating is marred.

### 5 Required supplementary information

For any particular application, the test method specified in this part of ISO 12137 needs to be completed by supplementary information. The items of supplementary information are given in annex A.

### 6 Apparatus

**6.1** A suitable tester<sup>2)</sup> is shown in figure 1. It consists principally of a counterbalanced beam with, mounted at one end, a pointed stylus. The test panel is placed on a sliding table which is motor-driven to move under the stylus at a speed of 600 mm/min. A continuous-loading weight mounted over the beam acts on the beam in such a way that, as the test panel passes under the stylus, the load on the stylus is continuously increased. The stylus-loading range can be varied by changing the continuous-loading weight (weights giving loading ranges of 0 to 50 g, 0 to 100 g

<sup>2)</sup> This apparatus is available from Shinton Scientific Ltd, 27 Higashi Konya-cho, Kanda, Chigoda-ku, Tokyo 101, Japan.

This information is given for the convenience of users of this part of ISO 12137 and does not constitute endorsement by ISO of the apparatus shown. Other types of scratch tester may be used if they can be shown to give similar relative ratings.

and 0 to 200 g are available, for instance). Mounted over the stylus itself is a small scale pan on which weights can be placed to expand the stylus-loading range (adding a weight of 100 g, for instance, changes a 0 to 200 g loading range to one of 100 g to 300 g).

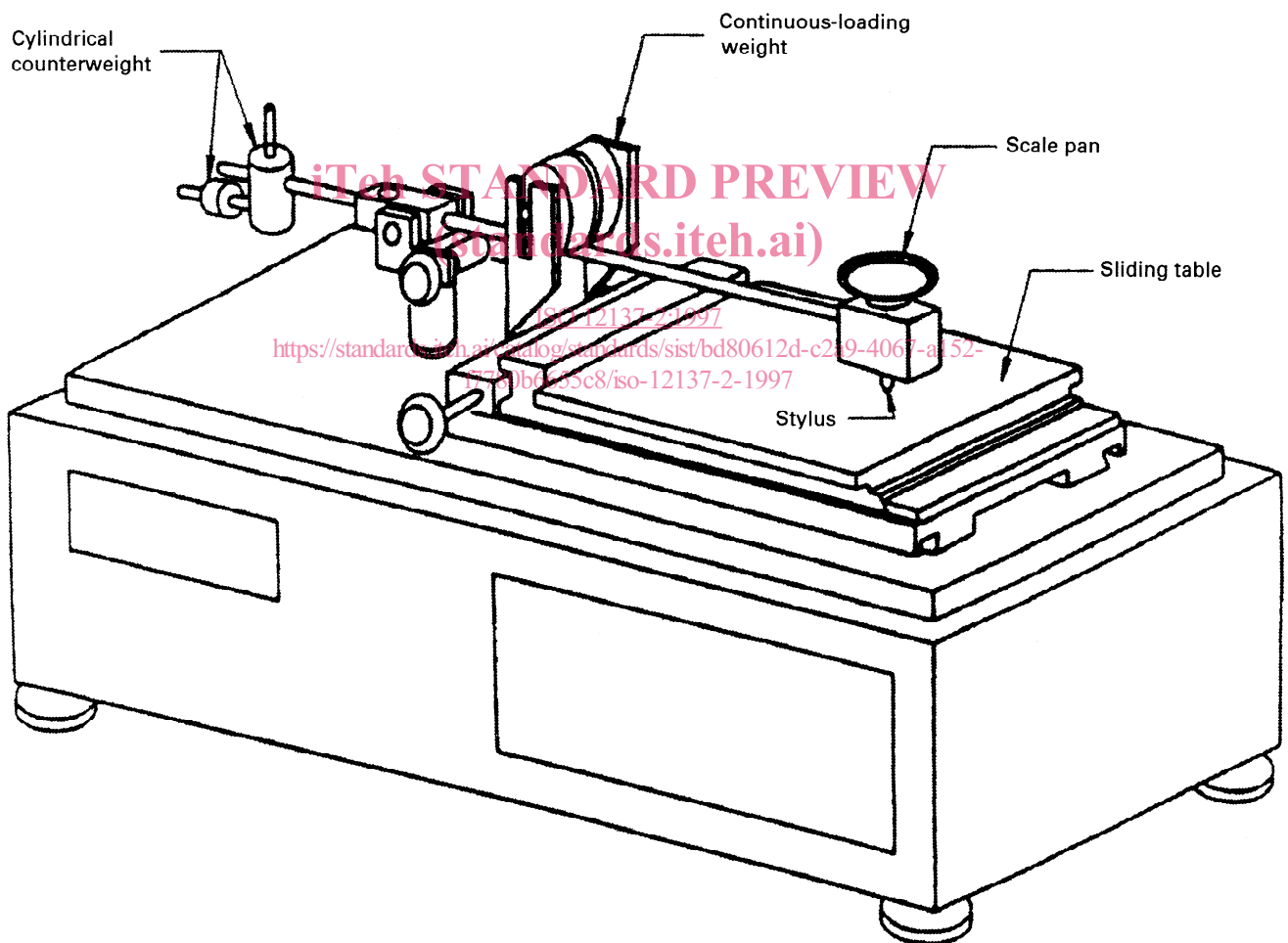
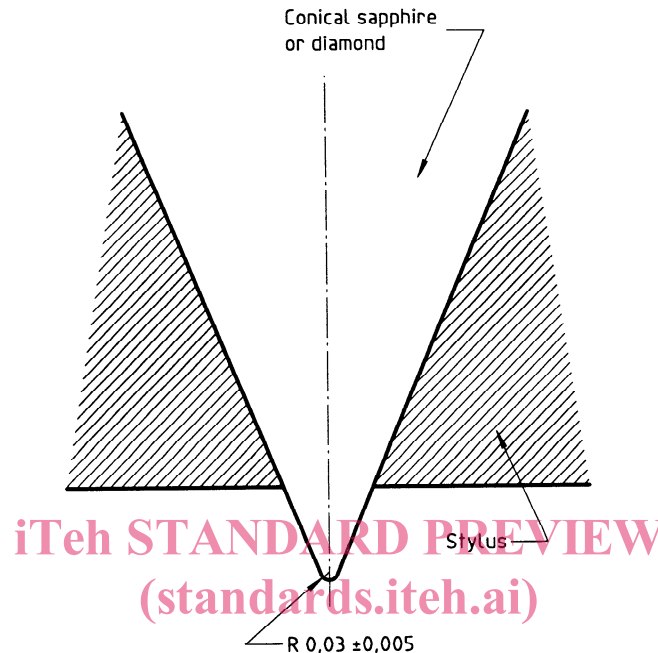

Figure 1 — Scratch tester with pointed stylus

**6.2** The stylus should preferably be tipped with a conical sapphire or diamond, the point of which is rounded to a radius of  $(0,03 \pm 0,005)$  mm (see figure 2).

NOTE — By agreement, sapphire or diamond stylus tips of other dimensions may be used.

Dimensions in millimetres



**Figure 2 — Stylus tipped with conical sapphire or diamond**

**6.3** A microscope, preferably with a magnification range extending up to  $\times 100$ , is required to examine the stylus. It may also be used to inspect the marred coating.

## 7 Sampling

**7.1** Take a representative sample of the product to be tested (or of each product in the case of a multi-coat system), as described in ISO 1512.

Examine and prepare each sample for testing, as described in ISO 1513.

## 8 Test panels

### 8.1 Substrate

Unless otherwise agreed, select the substrate from one of those described in ISO 1514 and, where possible, in accordance with the desired practical application. The panels shall be plane and free from distortion, with a maximum thickness of about 12 mm, and 100 mm to 400 mm wide and long.

### 8.2 Preparation and coating

Unless otherwise agreed, prepare each test panel in accordance with ISO 1514 and then coat it by the specified method with the product or system under test.

### 8.3 Drying and conditioning

Dry (or stove) and age, if applicable, each coated test panel for the specified time and under the specified conditions. Before testing, condition the coated panels at  $(23 \pm 2)$  °C and a relative humidity of  $(50 \pm 5)$  % unless otherwise agreed, for a minimum period of 16 h.

Fingerprints, dust or other contamination on the surface will result in a lower accuracy. The coated panels shall therefore be stored and handled in the appropriate way.

### 8.4 Thickness of coating

Determine the thickness, in micrometers, of the dried coating by one of the procedures specified in ISO 2808.

## 9 Procedure

### 9.1 Test conditions

Carry out the test at  $(23 \pm 2)$  °C and a relative humidity of  $(50 \pm 5)$  %, unless otherwise agreed.

### 9.2 Preparation for the test

Place the tester on a stable and level surface.

Level the tester, using the spirit level and adjustment nut fitted to the tester and the special adjustment tool supplied by the manufacturer of the tester.

Examine the stylus under the microscope, preferably at a magnification of  $\times 100$ , in accordance with the tester operation manual, to ensure that it is undamaged.

Clean the stylus, if necessary, with a clean cloth or lint-free paper.

### 9.3 Determination

Place a test panel up against the stop on the sliding table. Secure the panel in place by turning the securing screws evenly about one turn at a time.

Secure the stylus in the vertical position.

Adjust the cylindrical counterweights (see figure 1) so that, when the tip of the stylus is just touching the surface of the test panel, the load on the stylus is zero.

Adjust the height of the stylus to the thickness of the test panel, with the beam released and the stylus resting on the test panel.

Set the stylus-loading range to 0 to 50 g.

Start the tester at a rate of about 10 mm/s. It will stop automatically when the sliding table has moved 100 mm.

Unless otherwise agreed, inspect the coating for marring under a suitable magnification or with the naked eye.

If no marring occurs, select another suitable stylus-loading range, and continue in test areas that do not overlap until marring does occur. When marring has occurred, determine which type of defect is involved (see 3.1).

Repeat the determination at least twice (i.e. for a total of at least three determinations) on the same panel at the stylus-loading range at which marring occurs.

For each of the three determinations, measure the distance  $d$ , in millimetres, from the final-loading point (i.e. the point where the stylus stops moving) to the point where marring occurs.

## 10 Expression of results

For each of the three determinations carried out, calculate the load, in grams, at the point at which marring just occurs (referred to as the critical load), using the following equation:

$$\text{Critical load} = \frac{(100 - d)}{100} \times (F_f - F_i)$$

where

$d$  is the distance, in millimetres, from the final-loading point to the point where marring just occurs;

$F_i$  is the initial load, in grams, in the stylus-loading range selected;

$F_f$  is the final load, in grams, in the stylus-loading range selected.

NOTE — Some instruments use a scratch-intensity recorder to determine the load which causes marring of the paint film.

Calculate the mean critical load for the three determinations made on the test panel. Report the result to the nearest 1 g.

iTeh STANDARD PREVIEW  
(standards.iteh.ai)

## 11 Precision

See annex B.

ISO 12137-2:1997  
<https://standards.iteh.ai/catalog/standards/sist/bd80612d-c2a9-4067-a152-f7780b6655c8/iso-12137-2-1997>

## 11 Test report

The test report shall contain at least the following information:

- a) all details necessary to identify the product tested;
- b) reference to this part of ISO 12137 (ISO 12137-2);
- c) the type of apparatus used;
- d) the dimensions of the stylus used;
- e) whether marring was assessed using the naked eye or a microscope and, if a microscope was used, the magnification setting at which it was used;
- f) the test results:
  - 1) a description of those of the elements of marring defined in 3.1 which actually occurred (not all will necessarily occur),
  - 2) the mean critical load, in grams, at which each of these elements of marring occurred, as indicated in clause 10;
- g) any deviation from the test method specified;
- h) the date of the test.



## Annex A (normative)

### Required supplementary information

The items of supplementary information listed in this annex shall be supplied as appropriate to enable the method to be carried out.

The information required should preferably be agreed between the interested parties and may be derived, in part or totally, from an international or national standard or other document related to the product under test.

- a) Substrate material, substrate thickness and surface preparation of the substrate.
- b) Method of application of the test coating to the substrate.
- c) Duration and conditions of drying (or stoving) and ageing (if applicable) of the coating before testing.
- d) Thickness, in micrometres, of the dry coating and method of measurement in accordance with ISO 2808, and whether it is a single coating or a multi-coat system.
- e) Temperature and humidity of the test, if different from those specified in 9.1.

ITh STANDARD PREVIEW

(standards.iteh.ai)

[ISO 12137-2:1997](https://standards.iteh.ai/catalog/standards/sist/bd80612d-c2a9-4067-a152-f7780b6655c8/iso-12137-2-1997)

<https://standards.iteh.ai/catalog/standards/sist/bd80612d-c2a9-4067-a152-f7780b6655c8/iso-12137-2-1997>