

INTERNATIONAL STANDARD

ISO
9693

Second edition
1999-12-15

Metal-ceramic dental restorative systems

Systèmes pour restaurations dentaires métallo-céramiques

iTeh STANDARD PREVIEW
(standards.iteh.ai)

[ISO 9693:1999](#)

<https://standards.iteh.ai/catalog/standards/sist/0bb97e2b-f994-4644-93dc-36e589bd5299/iso-9693-1999>



Reference number
ISO 9693:1999(E)

© ISO 1999

PDF disclaimer

This PDF file may contain embedded typefaces. In accordance with Adobe's licensing policy, this file may be printed or viewed but shall not be edited unless the typefaces which are embedded are licensed to and installed on the computer performing the editing. In downloading this file, parties accept therein the responsibility of not infringing Adobe's licensing policy. The ISO Central Secretariat accepts no liability in this area.

Adobe is a trademark of Adobe Systems Incorporated.

Details of the software products used to create this PDF file can be found in the General Info relative to the file; the PDF-creation parameters were optimized for printing. Every care has been taken to ensure that the file is suitable for use by ISO member bodies. In the unlikely event that a problem relating to it is found, please inform the Central Secretariat at the address given below.

iTeh STANDARD PREVIEW
(standards.iteh.ai)

[ISO 9693:1999](#)

<https://standards.iteh.ai/catalog/standards/sist/0bb97e2b-f994-4644-93dc-36e589bd5299/iso-9693-1999>

© ISO 1999

All rights reserved. Unless otherwise specified, no part of this publication may be reproduced or utilized in any form or by any means, electronic or mechanical, including photocopying and microfilm, without permission in writing from either ISO at the address below or ISO's member body in the country of the requester.

ISO copyright office
Case postale 56 • CH-1211 Geneva 20
Tel. + 41 22 749 01 11
Fax + 41 22 734 10 79
E-mail copyright@iso.ch
Web www.iso.ch

Printed in Switzerland

Contents

Page

Foreword.....	iv
Introduction.....	v
1 Scope	1
2 Normative references	1
3 Terms and definitions	1
4 Requirements	2
5 Sampling	4
6 Test methods	4
7 Information and instructions	10
8 Packaging, marking and labelling	11
Bibliography	14

iTeh STANDARD PREVIEW
(standards.iteh.ai)

[ISO 9693:1999](https://standards.iteh.ai/catalog/standards/sist/0bb97e2b-f994-4644-93dc-36e589bd5299/iso-9693-1999)

<https://standards.iteh.ai/catalog/standards/sist/0bb97e2b-f994-4644-93dc-36e589bd5299/iso-9693-1999>

Foreword

ISO (the International Organization for Standardization) is a worldwide federation of national standards bodies (ISO member bodies). The work of preparing International Standards is normally carried out through ISO technical committees. Each member body interested in a subject for which a technical committee has been established has the right to be represented on that committee. International organizations, governmental and non-governmental, in liaison with ISO, also take part in the work. ISO collaborates closely with the International Electrotechnical Commission (IEC) on all matters of electrotechnical standardization.

International Standards are drafted in accordance with the rules given in the ISO/IEC Directives, Part 3.

Draft International Standards adopted by the technical committees are circulated to the member bodies for voting. Publication as an International Standard requires approval by at least 75 % of the member bodies casting a vote.

International Standard ISO 9693 was prepared by Technical Committee ISO/TC 106, *Dentistry*, Subcommittee SC 2, *Prosthetic materials*.

Attention is drawn to the possibility that some of the elements of this International Standard may be the subject of patent rights. ISO shall not be held responsible for identifying any or all such patent rights.

This second edition cancels and replaces the first edition (ISO 9693:1991), which has been technically revised.

Significant differences between this second edition and the first edition are:

- the scope includes metallic materials (not only alloys) processed by casting or machining;
- a requirement (4.3.3) and a test (6.3.3) on the debonding/crack-initiation strength for the metal-ceramic system have been added, replacing the previous requirement and test related to metal-ceramic bond characterization.

Introduction

Dental metallic materials and ceramics are suitable for use in fabrication of metal-ceramic dental restorations.

Specific qualitative and quantitative requirements for freedom from biological hazards are not included in this International Standard, but it is recommended that, in assessing possible biological hazards, reference be made to ISO 10993-1 and ISO 7405.

Requirements and test methods for tarnish and corrosion resistance for the components and for the metal-ceramic system will be included in the future when they are available.

iTeh STANDARD PREVIEW (standards.iteh.ai)

[ISO 9693:1999](https://standards.iteh.ai/catalog/standards/sist/0bb97e2b-f994-4644-93dc-36e589bd5299/iso-9693-1999)

<https://standards.iteh.ai/catalog/standards/sist/0bb97e2b-f994-4644-93dc-36e589bd5299/iso-9693-1999>

iTeh STANDARD PREVIEW
(standards.iteh.ai)

ISO 9693:1999

<https://standards.iteh.ai/catalog/standards/sist/0bb97e2b-f994-4644-93dc-36e589bd5299/iso-9693-1999>

Metal-ceramic dental restorative systems

1 Scope

This International Standard specifies requirements and test methods for dental metallic materials processed by casting or machining, and for ceramics suitable for use in the fabrication of metal-ceramic dental restorations, together with requirements and test methods for the composite structure.

The requirements of this International Standard apply to the metallic materials and ceramics when used in combination, and compliance may not be claimed for either metallic materials or for ceramics alone.

2 Normative references

The following normative documents contain provisions which, through reference in this text, constitute provisions of this International Standard. For dated references, subsequent amendments to, or revisions of, any of these publications do not apply. However, parties to agreements based on this International Standard are encouraged to investigate the possibility of applying the most recent editions of the normative documents indicated below. For undated references, the latest edition of the normative document referred to applies. Members of ISO and IEC maintain registers of currently valid International Standards.

ISO 3696:1987, *Water for analytical laboratory use — Specification and test methods.*
<https://standards.iteh.ai/catalog/standards/sist/0bb97e2b-f994-4644-93dc-36e589bd5299/iso-9693-1999>

ISO 6872:1995, *Dental ceramic.*

ISO 6892:1998, *Metallic materials — Tensile testing at ambient temperature.*

ASTM B 265-95, *Standard specification for titanium and titanium alloy strip, sheet and plate.*

ASTM B 348-93, *Standard specification for titanium and titanium alloy bars and billets.*

3 Terms and definitions

For the purposes of this International Standard, the following terms and definitions apply.

3.1

alloy/metal conditioning

process of treating the metal substructure to enhance the bonding of ceramic to metal

3.2

coating agent

bonding agent

substance which, when applied to the metal substructure and fired under appropriate time-temperature conditions, improves aesthetics and may enhance the adherence of ceramic to the coated metal surface

NOTE Examples of such substances are electroplated layers, or agents containing ceramic and/or alloy particles.

3.3

dental dentine ceramic

slightly translucent, pigmented dental ceramic used to impart the overall shape and basic colour of the ceramic part of a metal-ceramic restoration or prosthesis

3.4

dental enamel ceramic

translucent, lightly pigmented dental ceramic, used on a core or a base of dentine ceramic to simulate the natural tooth enamel

3.5

firing schedule

temperature-time cycle stating the initial temperature, the time period (if any) at the initial temperature, the heating rate, the final temperature, the time period (if any) at the final temperature and, in the case of vacuum firing, the temperature of vacuum application and the point of release

3.6

heating rate

rate of temperature increase

NOTE It is expressed in degrees Celsius per minute.

3.7

metallic material

alloy or metal suitable for use as the substructure of a metal-ceramic restoration

3.8

opaque bonding dental ceramic

ceramic product that, when mixed with distilled water or other appropriate liquid, applied to a dental metallic material and treated according to the firing schedule for the **opaque ceramic**, will bond to the metal surface to form a layer that visibly masks the metallic colour

iteh STANDARD PREVIEW
(standards.iteh.ai)
<https://standards.iteh.ai/catalog/standards/sist/0bb97e2b-f994-4644-93dc-36e589bd5299/iso-9693-1999>

4 Requirements

4.1 Chemical composition

4.1.1 Metallic material

For noble metal alloys, the percentage of each alloy constituent shall not deviate from the value stated on the package label or insert by more than 0,5 % (mass fraction) [see 8.2.2 c)].

For base metal alloys, the content of constituents present in excess of 20 % (mass fraction) shall not deviate from the value stated on the package label or insert by more than 2 % (mass fraction). The content of constituents present in excess of 2 % (mass fraction) but not in excess of 20 % (mass fraction) shall not deviate from the value stated on the package label or insert by more than 1 % (mass fraction) [see 8.2.2 c)].

The percentage content of nickel, beryllium and cadmium shall not be greater than the amounts indicated on the package label or insert [see 8.2.2 d)].

Testing shall be carried out in accordance with 6.1.1.

For unalloyed titanium, the grade according to ASTM Designation B 265-95 (strip, sheet and plate) or B 348-93 (bars and billets) shall be certified, i.e. standard specification data apply. A certificate from the supplier of the titanium shall be required.

4.1.2 Ceramic

The ceramic shall meet the requirements of ISO 6872:1995/Amd.1:1997, 5.1 and 5.2. Test in accordance with ISO 6872:1995/Amd. 1:1997.

4.2 Biocompatibility

See the Introduction for guidance on biocompatibility.

4.3 Properties

4.3.1 Metallic material

The mechanical properties of the metallic materials as processed shall comply with the requirements of Table 1.

Table 1 — Mechanical properties of metallic materials

Proof stress of non-proportional elongation, $R_{p0,2}$ MPa min.	Percentage elongation after fracture %min.
250	3

ISO 9693:1999

<https://standards.iteh.ai/catalog/standards/sist/0bb97e2b-f994-4644-93dc-36e589bd5299/iso-9693-1999>

The solidus and liquidus temperatures of the alloys shall not deviate by more than 25 °C from the values stated on the package label or insert [see 8.2.2 g)].

The coefficient of linear thermal expansion of the alloys shall not deviate by more than $0,5 \times 10^{-6} \text{ K}^{-1}$ from the value stated on the package label or insert [see 8.2.2 h)].

The density of the alloy as supplied by the manufacturer shall not deviate by more than $0,5 \text{ g/cm}^3$ from the value stated on the package label or insert [see 8.2.2 i)].

Testing shall be carried out in accordance with 6.1.2, 6.1.3, and 6.3.1, respectively. Standard testing procedures shall be used for determining the density.

NOTE For titanium and other pure metals, controlled literature data for melting point, linear thermal expansion and density can be used; see e.g. [8].

4.3.2 Ceramic

The flexural strength and the chemical solubility of the fired ceramics shall meet the requirements of Table 2.

Table 2 — Properties of ceramics

Ceramic type	Flexural strength	Chemical solubility, loss in mass
	MPa min.	$\mu\text{g}\cdot\text{cm}^{-2}$ max.
Opaque	50	100
Dentine	50	100
Enamel	50	100

The coefficient of thermal expansion of the ceramics shall not deviate by more than $0,5 \times 10^{-6} \text{ K}^{-1}$ from the value stated by the manufacturer [see 8.2.3 e)].

The glass transition temperature of the ceramics shall not deviate by more than 20 °C from the value stated by the manufacturer [see 8.2.3 f)].

Testing shall be carried out in accordance with 6.2.1, 6.3.1, and 6.3.2, respectively.

4.3.3 Metal-ceramic system

The debonding/crack-initiation strength of the metallic material and at least one specified (named) ceramic present shall be greater than 25 MPa. The debonding/crack-initiation strength of the ceramic and at least one specified (named) metallic material present shall be greater than 25 MPa.

Testing shall be carried out in accordance with 6.3.3.

The measured values for coefficients of linear thermal expansion are compared with the manufacturer's values as a means of quality control, but the values cannot provide an assurance that the alloy and ceramic are compatible.

5 Sampling

5.1 Metallic material

The sample shall be adequate to prepare the specimens for testing in accordance with this International Standard. All of the metallic materials procured shall be unused and obtained from the same batch.

5.2 Ceramic

Take a sufficient amount of ceramic to carry out the necessary tests in accordance with this International Standard. If there is more than one shade of opaque, dentine and enamel ceramics, respectively, take equal quantities of each shade.

6 Test methods

6.1 Metallic material

6.1.1 Chemical composition

Use standard analytical procedures for determining the composition.

For unalloyed titanium, specification data in accordance with 4.1.1 shall be provided by the manufacturer or distributor of the metal.

6.1.2 Mechanical properties

6.1.2.1 Preparation of test specimens

Prepare six test specimens, as depicted in Figure 1 or 2, in accordance with the manufacturer's procedure for processing the substructures for metal-ceramic prostheses. Discard and replace specimens with visible defects.

Preheat the furnace. Place the metallic specimens in the furnace for 15 min with the atmosphere recommended for the metallic material concerned. Use the highest temperature allowed with respect to the ceramic(s) recommended for fusing to that metallic material. Remove the specimens from the furnace, place them on a refractory plate and allow them to cool. Use the specimens for the tests in 6.1.2.2 and 6.1.2.3.

6.1.2.2 Proof stress of non-proportional elongation

Determine the proof stress of non-proportional elongation in accordance with ISO 6892 using the test specimens, processed and conditioned in accordance with 6.1.2.1. Load the test specimens in a universal mechanical testing instrument at a cross-head speed of $(1,5 \pm 0,5)$ mm/min until fracture occurs.

Determine the values from the resultant stress-strain curves at the 0,2 % offset level and calculate the proof stress on the basis of the original cross-sectional area.

If four or more specimens are found to comply with the requirement in Table 1, calculate the proof stress as the mean value for those specimens, and report it to the nearest 5 MPa.

If fewer than four specimens comply with the requirements specified in Table 1, repeat the test.

If again fewer than four specimens comply with the requirement specified in Table 1, the metallic material does not pass the test.

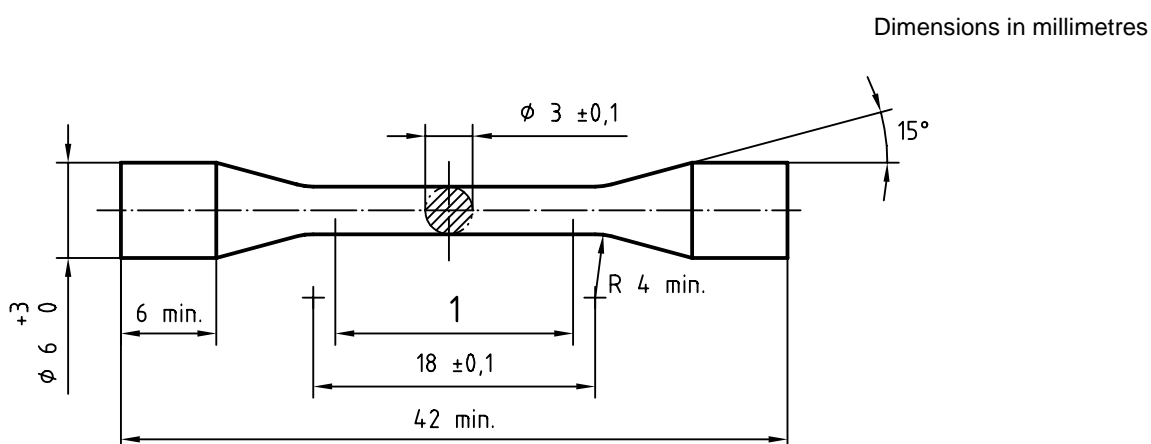

Key

1 Gauge length $15 \pm 0,1$

Figure 1 — Test specimen with conical shoulders