**Ships and marine technology — Small
weathertight steel hatches**

*Navires et technologie maritime — Petits panneaux en acier, étanches aux
intempéries*

iTeh STANDARD PREVIEW
(standards.iteh.ai)

ISO 5778:1998

<https://standards.iteh.ai/catalog/standards/sist/65717824-7c27-4ff5-8015-3008ba0095e2/iso-5778-1998>



Foreword

ISO (the International Organization for Standardization) is a worldwide federation of national standards bodies (ISO member bodies). The work of preparing International Standards is normally carried out through ISO technical committees. Each member body interested in a subject for which a technical committee has been established has the right to be represented on that committee. International organizations, governmental and non-governmental, in liaison with ISO, also take part in the work. ISO collaborates closely with the International Electrotechnical Commission (IEC) on all matters of electrotechnical standardization.

Draft International Standards adopted by the technical committees are circulated to the member bodies for voting. Publication as an International Standard requires approval by at least 75 % of the member bodies casting a vote.

International Standard ISO 5778 was prepared by Technical Committee ISO/TC 8, *Ships and marine technology*, Subcommittee SC 8, *Structures*.

This second edition cancels and replaces the first edition (ISO 5778:1979), of which it constitutes a technical revision.

Amendments

The following amendments have been made to the first edition (1979-12-15).

- iTeh STANDARD PREVIEW**
(standards.iteh.ai)
- a) The nominal size 830 × 630 has been added.
 - b) The inclined and vertical position of the hatch-seal retaining bar has been admitted.
ISO 5778:1998
<https://standards.iteh.ai/catalog/standards/sist/65717824-7c27-4f5-8015-3008b0095e24/iso-5778-1998>
 - c) The tolerances for a , b , a_1 and b_2 have been added in tables 2 and 3.
 - d) The text of 3.4.2 has been supplemented.
 - e) The distance between the hinge's pivot and the coaming has been changed from 55 mm to 60 mm.
 - f) The minimum tensile strength of the steel for coamings, cover plates, hinges, etc. has been changed to 340 N/mm².
 - g) The designation has been added.
 - h) The standard has been editorially revised.

© ISO 1998

All rights reserved. Unless otherwise specified, no part of this publication may be reproduced or utilized in any form or by any means, electronic or mechanical, including photocopying and microfilm, without permission in writing from the publisher.

International Organization for Standardization
Case postale 56 • CH-1211 Genève 20 • Switzerland
Internet iso@iso.ch

Printed in Switzerland

Ships and marine technology — Small weathertight steel hatches

1 Scope

This International Standard specifies the main dimensions, location and number of fittings, materials and quality of manufacture for small weathertight steel hatches for application on board ships in order to ensure interchangeability of the hatches. The remaining dimensions are left to the manufacturer.

The hatches are suitable for loading operations and for giving access to storage compartments and dry cargo holds. The hatches are not suitable as an access to any kind of tanks and shall not be used as escape hatches.

These hatches generally conform to the requirements of the International Convention on Load Lines 1966 (LLC66). The possibility for application in position 1 and position 2 has to be considered for each situation and, where necessary, the hatch covers shall be provided with additional stiffening.

NOTE — Users of this International Standard should note that while observing the requirements of this standard, they should, at the same time, ensure compliance with such statutory requirements, rules and regulations as may be applicable to the individual ship concerned.

2 Normative reference

The following standard contains provisions which, through reference in this text, constitute provisions of this International Standard. At the time of publication, the edition indicated was valid. All standards are subject to revision, and parties to agreements based on this International Standard are encouraged to investigate the possibility of applying the most recent edition of the standard indicated below. Members of IEC and ISO maintain registers of currently valid International Standards.

ISO 262:—1), *ISO general-purpose metric screw threads – Selected sizes for screws, bolts and nuts*.

1) To be published. (Revision of ISO 262:1973)

3 Main dimensions

3.1 Nominal size

The nominal size of a hatch is based on the inside dimensions of the upper part of the coaming, as shown in figure 1 and table 1.

Dimensions in millimetres

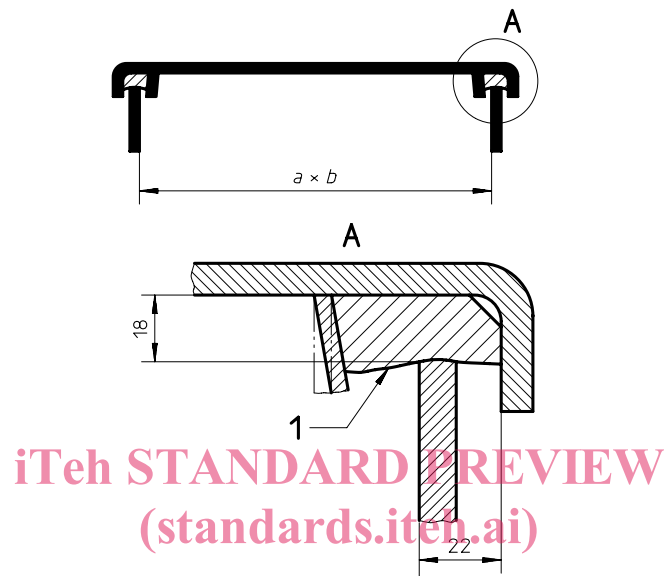

ISO 5778:1998
<https://standards.iteh.ai/catalog/standards/sist/65717824-7c27-4b5-8015-0095e2/iso-5778-1998>
 Key
 1 Hatch seal

Figure 1 — Illustration of nominal sizes

Table 1 — Values of nominal sizes

Dimensions in millimetres

Nominal size $a \times b$
630 × 630
630 × 830
830 × 630
830 × 830
1 030 × 1 030
1 330 × 1 330

3.2 Upper part of coaming

The upper part of the coaming shall conform to the details of figure 2 and table 2. The coaming may have square or rounded corners as shown in figure 2.

In order to prevent damage of the hatch seal, the edges of the upper part of the coaming should be rounded or chamfered.

Dimensions in millimetres

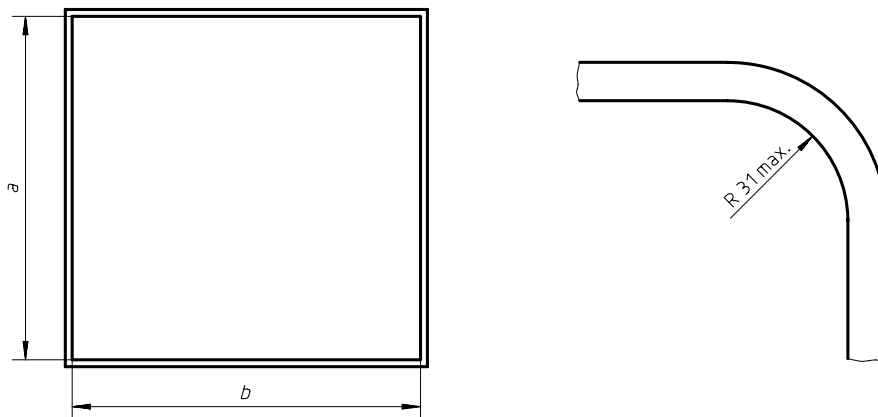

Figure 2 — Upper part of coaming

iTeh STANDARD PREVIEW
(standards.iteh.ai)

ISO 5778:1998

<https://standards.iteh.ai/catalog/standards/sist/65717824-7c27-4f5-8015-3008ba0095e2/iso-5778-1998>

Table 2 — Sizes of coaming

Dimensions in millimetres

Nominal size	<i>a</i>	<i>b</i>
	0 -2	0 -2
630 × 630	630	630
630 × 830	630	830
830 × 630	830	630
830 × 830	830	830
1 030 × 1 030	1 030	1 030
1 330 × 1 330	1 330	1 330

3.3 Cover plate

The cover plate shall conform to the details of figure 3 and table 3.

Where the nominal size of the cover plate exceeds 830 mm × 830 mm, the cover plate shall be stiffened in accordance with Regulation 16 (2) of the International Convention on Load Lines (ILLC) 1966.

The hatch-seal retaining bar can be placed in an inclined or vertical position, as indicated in figure 3.

Dimensions in millimetres

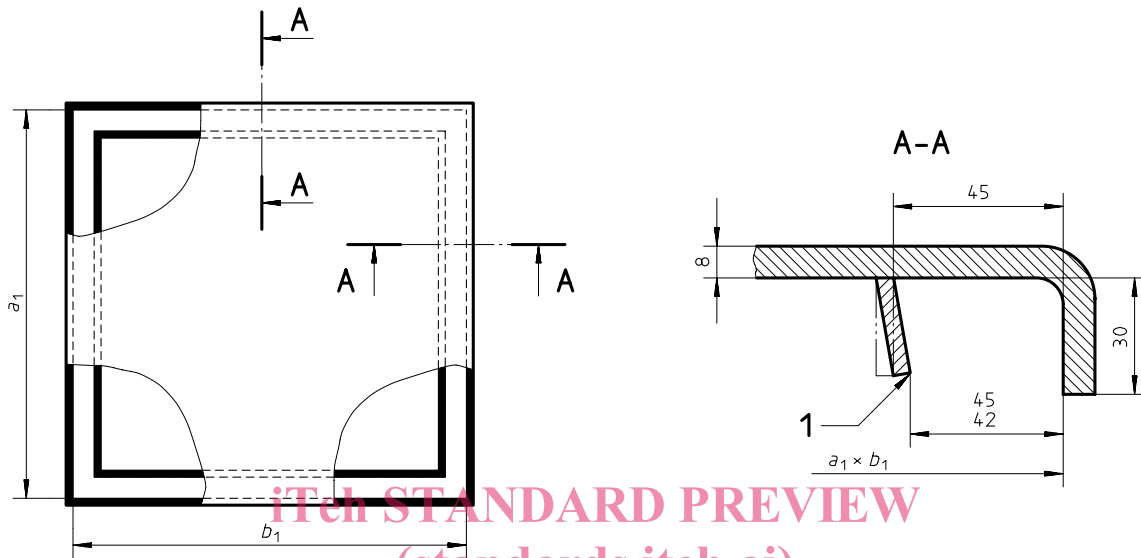

STANDARD PREVIEW
(standards.iteh.ai)

Key

- 1 Hatch seal retaining bar
Flat 25 × 4

ISO 5778:1998

<https://standards.iteh.ai/catalog/standards/sist/65717824-7c27-4f5-8015-3008ba0095e2/iso-5778-1998>

Dimensions in millimetres

Nominal size	a_1 ± 2	b_1 ± 2
630 × 630	674	674
630 × 830	674	874
830 × 830	874	874
1 030 × 1 030	1 074	1 074
1 330 × 1 330	1 374	1 374

3.4 Fittings

3.4.1 Location of closing devices and hinges

All the values given in figure 4, for centre lines of closing devices and hinges, refer to the inside dimensions (nominal size) of the upper part of the coaming.

Dimensions in millimetres

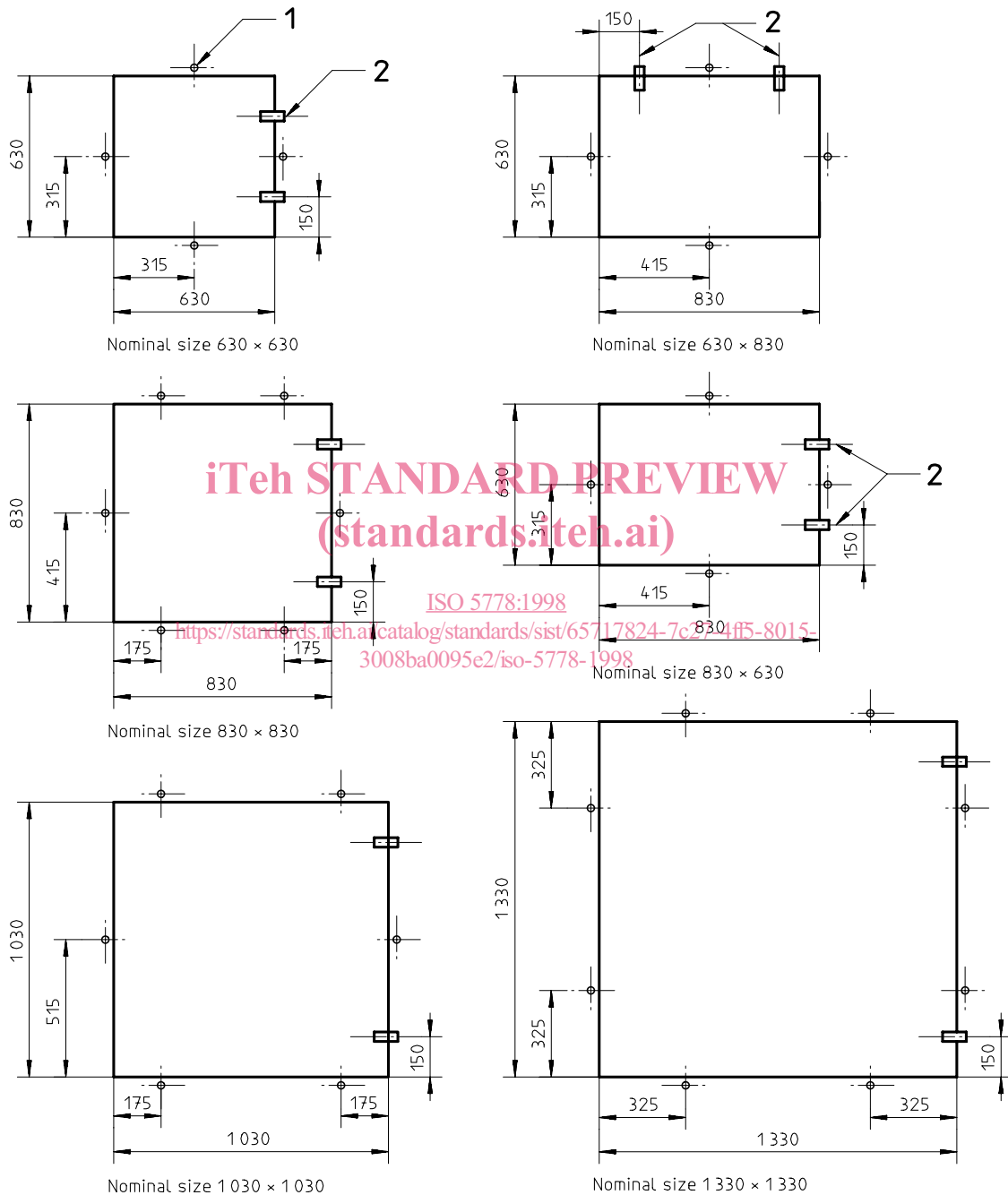

Key

- 1 Closing device
- 2 Centre line of hinge

3.4.2 Closing devices

Closing devices shall conform to the dimensions of figure 5.

The wing nut shall be suitable for applying a torque convenient for tightness, by only one man without the help of any tools. Threads of wing nuts and toggle bolts shall be in accordance with ISO 262.

Dimensions in millimetres

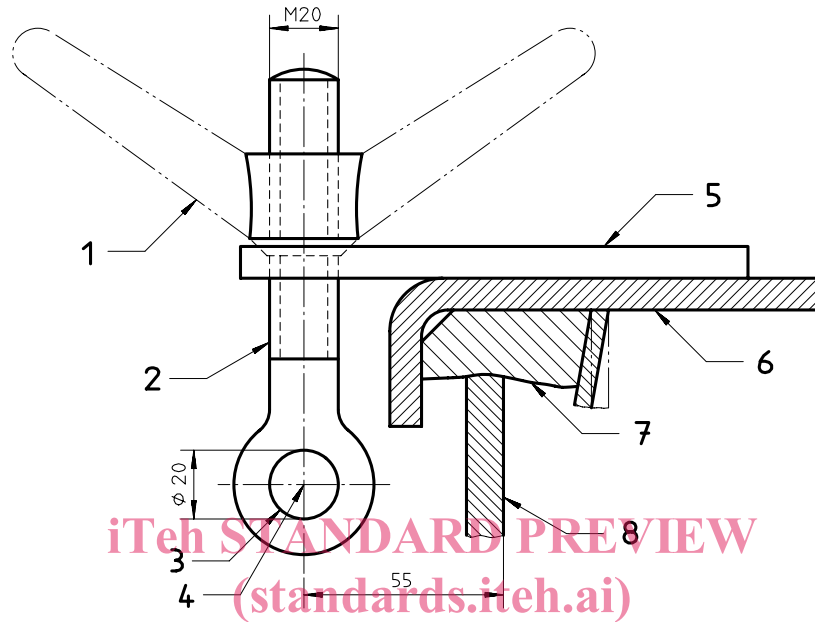

Key

- 1 Wing nut (typical shape)
- 2 Toggle bolt
- 3 Toggle bolt pin
- 4 Centre of toggle bolt
- 5 Lug
- 6 Cover plate
- 7 Hatch seal
- 8 Coaming

Figure 5 — Closing device

3.4.3 Hinges

Two hinges shall be fitted to each hatch and shall conform to the dimensions of figure 6. Each hinge shall be provided with an oval hole, in order to allow the closing devices to compress the hatch seal.

Dimensions in millimetres

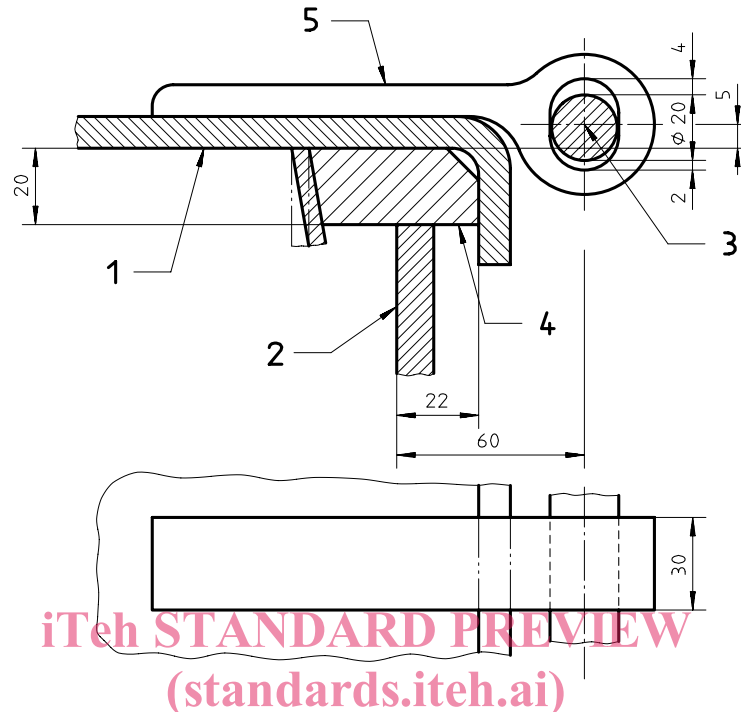

Key

- 1 Cover plate [ISO 5778:1998](#)
- 2 Coaming <http://standards.iteh.ai/catalog/standards/sist/65717824-7c27-4b5-8015-3008ba0095e2/iso-5778-1998>
- 3 Centre of hinge pin
- 4 Hatch seal, non-compressed
- 5 Typical shape

Figure 6 —

3.4.4 Hatch seal

The hatch seal shall have a cross-section of 45 mm x 20 mm (see figure 7), an initial compression of 2 mm being allowed.

The hatch seal shall be fitted to the cover plates as indicated in figure 1 and shall be secured by a retaining bar. The hatch seal shall be bonded to the cover plate by an adhesive suitable for marine conditions.

It shall be ensured, by a depth stop positioned on or near the centre line of each closing device, that the hatch seal material cannot be compressed more than 4 mm.

Dimensions in millimetres

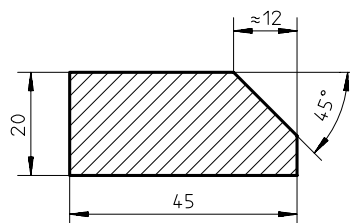

Figure 7 — Hatch seal, cross-section