

INTERNATIONAL STANDARD

NORME INTERNATIONALE

AMENDMENT 1 AMENDEMENT 1

Household and similar electrical appliances – Safety –
Part 2-6: Particular requirements for stationary cooking ranges, hobs, ovens and
similar appliances

Appareils électrodomestiques et analogues – Sécurité –
Partie 2-6: Exigences particulières pour les cuisinières, les tables de cuisson,
les fours et les appareils fixes analogues





THIS PUBLICATION IS COPYRIGHT PROTECTED
Copyright © 2018 IEC, Geneva, Switzerland

All rights reserved. Unless otherwise specified, no part of this publication may be reproduced or utilized in any form or by any means, electronic or mechanical, including photocopying and microfilm, without permission in writing from either IEC or IEC's member National Committee in the country of the requester. If you have any questions about IEC copyright or have an enquiry about obtaining additional rights to this publication, please contact the address below or your local IEC member National Committee for further information.

Droits de reproduction réservés. Sauf indication contraire, aucune partie de cette publication ne peut être reproduite ni utilisée sous quelque forme que ce soit et par aucun procédé, électronique ou mécanique, y compris la photocopie et les microfilms, sans l'accord écrit de l'IEC ou du Comité national de l'IEC du pays du demandeur. Si vous avez des questions sur le copyright de l'IEC ou si vous désirez obtenir des droits supplémentaires sur cette publication, utilisez les coordonnées ci-après ou contactez le Comité national de l'IEC de votre pays de résidence.

IEC Central Office
3, rue de Varembe
CH-1211 Geneva 20
Switzerland

Tel.: +41 22 919 02 11
info@iec.ch
www.iec.ch

About the IEC

The International Electrotechnical Commission (IEC) is the leading global organization that prepares and publishes International Standards for all electrical, electronic and related technologies.

About IEC publications

The technical content of IEC publications is kept under constant review by the IEC. Please make sure that you have the latest edition, a corrigendum or an amendment might have been published.

IEC publications search - webstore.iec.ch/advsearchform

The advanced search enables to find IEC publications by a variety of criteria (reference number, text, technical committee,...). It also gives information on projects, replaced and withdrawn publications.

IEC Just Published - webstore.iec.ch/justpublished

Stay up to date on all new IEC publications. Just Published details all new publications released. Available online and once a month by email.

IEC Customer Service Centre - webstore.iec.ch/csc

If you wish to give us your feedback on this publication or need further assistance, please contact the Customer Service Centre: sales@iec.ch.

Electropedia - www.electropedia.org

The world's leading online dictionary on electrotechnology, containing more than 22,000 terminological entries in English and French, with equivalent terms in 16 additional languages. Also known as the International Electrotechnical Vocabulary (IEV) online.

IEC Glossary - std.iec.ch/glossary

67,000 electrotechnical terminology entries in English and French extracted from the Terms and definitions clause of IEC publications issued between 2002 and 2015. Some entries have been collected from earlier publications of IEC TC 37, 77, 86 and CISPR.

A propos de l'IEC

La Commission Electrotechnique Internationale (IEC) est la première organisation mondiale qui élabore et publie des Normes internationales pour tout ce qui a trait à l'électricité, à l'électronique et aux technologies apparentées.

A propos des publications IEC

Le contenu technique des publications IEC est constamment revu. Veuillez vous assurer que vous possédez l'édition la plus récente, un corrigendum ou amendement peut avoir été publié.

Recherche de publications IEC - webstore.iec.ch/advsearchform

La recherche avancée permet de trouver des publications IEC en utilisant différents critères (numéro de référence, texte, comité d'études,...). Elle donne aussi des informations sur les projets et les publications remplacées ou retirées.

IEC Just Published - webstore.iec.ch/justpublished

Restez informé sur les nouvelles publications IEC. Just Published détaille les nouvelles publications parues. Disponible en ligne et une fois par mois par email.

Service Clients - webstore.iec.ch/csc

Si vous désirez nous donner des commentaires sur cette publication ou si vous avez des questions contactez-nous: sales@iec.ch.

Electropedia - www.electropedia.org

Le premier dictionnaire d'électrotechnologie en ligne au monde, avec plus de 22 000 articles terminologiques en anglais et en français, ainsi que les termes équivalents dans 16 langues additionnelles. Egalement appelé Vocabulaire Electrotechnique International (IEV) en ligne.

Glossaire IEC - std.iec.ch/glossary

67 000 entrées terminologiques électrotechniques, en anglais et en français, extraites des articles Termes et définitions des publications IEC parues entre 2002 et 2015. Plus certaines entrées antérieures extraites des publications des CE 37, 77, 86 et CISPR de l'IEC.

INTERNATIONAL STANDARD

NORME INTERNATIONALE

AMENDMENT 1
AMENDEMENT 1

**Household and similar electrical appliances – Safety –
Part 2-6: Particular requirements for stationary cooking ranges, hobs, ovens and
similar appliances**

**Appareils électrodomestiques et analogues – Sécurité –
Partie 2-6: Exigences particulières pour les cuisinières, les tables de cuisson,
les fours et les appareils fixes analogues**

INTERNATIONAL
ELECTROTECHNICAL
COMMISSION

COMMISSION
ELECTROTECHNIQUE
INTERNATIONALE

ICS 13.120; 97.040.20

ISBN 978-2-8322-8559-6

**Warning! Make sure that you obtained this publication from an authorized distributor.
Attention! Veuillez vous assurer que vous avez obtenu cette publication via un distributeur agréé.**

FOREWORD

This amendment has been prepared by IEC technical committee 61: Safety of household and similar electrical appliances.

The text of this amendment is based on the following documents:

FDIS	Report on voting
61/5631/FDIS	61/5690/RVD

Full information on the voting for the approval of this amendment can be found in the report on voting indicated in the above table.

The committee has decided that the contents of this amendment and the base publication will remain unchanged until the stability date indicated on the IEC website under "http://webstore.iec.ch" in the data related to the specific publication. At this date, the publication will be

- reconfirmed,
- withdrawn,
- replaced by a revised edition, or
- amended.

iTeh STANDARD PREVIEW
(standards.iteh.ai)

NOTE The attention of National Committees is drawn to the fact that equipment manufacturers and testing organizations may need a transitional period following publication of a new, amended or revised IEC publication in which to make products in accordance with the new requirements and to equip themselves for conducting new or revised tests.

<https://standards.iteh.ai/catalog/standards/sist/0da4b5fe-857b-44c3-8f64-450a01e4c26c/iec-60335-2-6-amd1-2018>

It is the recommendation of the committee that the content of this publication be adopted for implementation nationally not earlier than 12 months or later than 36 months from the date of publication.

3 Terms and definitions

3.1.6 *In the addition, replace the Note 101 to entry by the following:*

Note 101 to entry: For appliances having more than three **heating units** per phase, other than those that are controlled by programmable **electronic circuits** that limit the input of heating elements and/or motors from being energized at the same time, a diversity factor is applied to the **rated current** or **rated power input** when determining the current used to establish the size of the terminals and the nominal cross-sectional area of the **supply cord**. The diversity factor F is calculated from the following formula, where N is the number of **heating units** per phase that can be energized together:

$$F = 0,35 + \frac{0,65}{\sqrt{N}}$$

3.1.9.101 *Add the following text after the existing third paragraph:*

Induction hob elements in a **flexible induction cooking zone** are operated with:

- a) the maximum number of vessels which can be separately controlled at the same time, arranged to cover the **flexible induction cooking zone** as far as possible. Any combination of vessels giving the most unfavourable results shall be used for the test. Several vessels with the same diameter may be used;

- b) the vessel which provides the highest power density (W/cm²);
- c) the smallest vessel that allows an **induction hob element** to operate.

Note 1 to entry: Vessels according to Figure 102 should be used for the tests. The vessel diameters specified in Figure 101 should be considered for the tests.

Operation as specified in a), b) or c), that results in the most unfavourable condition for the tests specified in the relevant subclauses is applied.

In the existing seventh paragraph, add before “induction wok elements” the words “those in a flexible induction cooking zone and”.

Add the following new term and definition:

3.124

flexible induction cooking zone

area on a **cooking zone** with **induction hob elements** that is not marked to indicate where vessels are to be placed for heating food

7 Marking and instructions

Add the following new subclause:

7.9 Addition:

iTeh STANDARD PREVIEW

(standards.iteh.ai)

Flexible induction cooking zone switches, **touch controls**, displays and the like shall be marked or placed so as to indicate clearly as to which vessel is assigned to which switch, **touch control**, display or the like.

IEC 60335-2-6:2014/AMD1:2018

<https://standards.iteh.ai/catalog/standards/sist/0da4b5fe-857b-44c3-8f64-486acb7c4c4/iec-60335-2-6-2014-amd1-2018>

11 Heating

11.7.102 *Delete the second sentence of the first paragraph and add a new paragraph stating “Ovens provided with a rotating spit are also operated with the spit rotating for 60 min”.*

11.101 *Add “except for the temperature setting” at the end of the first paragraph.*

15 Moisture resistance

15.2 *Replace the existing text by the following:*

Cooking ranges and **hobs** are positioned so that the **hob surface** is horizontal. A vessel having the largest diameter shown in Figure 101, that does not exceed the diameter of the **cooking zone**, is completely filled with the spillage solution and positioned centrally over the **cooking zone**. A further quantity of 0,5 l of the spillage solution is poured steadily into the vessel over a period of 15 s. The test is carried out on each **cooking zone** in turn, after removing any residual spillage solution from the appliance.

For **hob elements** incorporating a switch or a thermal control, 0,02 l of the spillage solution is poured over the **hob element** so that it flows over the switch or control. A vessel is then placed on the **hob element** to depress any movable part. If controls are mounted in the hob surface, 0,5 l of the spillage solution is poured over them in a period of 15 s.

For **hobs** having ventilating openings in the **hob surface**, 0,2 l of the spillage solution is poured steadily through a funnel onto the ventilating openings. The funnel has an outlet diameter of 8 mm and is positioned vertically with the outlet 200 mm above the **hob surface**. The funnel is positioned above the ventilating openings so that the spillage solution enters the appliance in the most unfavourable way.

*If the opening is protected, the funnel is positioned so that the spillage solution falls onto the **hob surface** as close as possible to the opening.*

Care is to be taken to ensure that the spillage solution is not poured over controls located close to ventilating openings.

*For **ovens** and **grills**, 0,5 l of the spillage solution is poured over the floor of the **oven** or grilling compartment.*

*For appliances having a drip tray or similar receptacle, the receptacle is filled with the spillage solution. A further quantity of the spillage solution, equal to 0,01 l per 100 cm² of the area of the top surface of the receptacle, is poured onto the receptacle through openings in the **hob surface**. However, the total quantity of spillage solution shall not exceed 3 l.*

*For **hobs** having a lid, 0,5 l of the spillage solution is poured uniformly over the closed lid. When the spillage solution has run off, the surface is dried and a further 0,125 l of the spillage solution is poured steadily from a height of approximately 50 mm onto the centre of the lid over a period of 15 s. The lid is then opened as in normal use.*

***Hobs** with controls mounted below the **hob surface** and **built-in ovens** that are intended for use installed under work surfaces shall be subjected to a spillage test with 0,5 l of the spillage solution. They shall be installed according to the manufacturer's instructions except that the front surface of the **oven** (excluding control knobs, handles) shall align with front edge of a 30 mm thick wooden work surface with a square front edge, see Figure 105. The spillage solution shall be poured on the work surface at the area which gives the most unfavourable conditions representing the pouring likely to occur, so that the spillage solution flows down the front surface of the **oven** over controls, joints, vents and similar openings. If necessary, the test is repeated until all different controls or gaps are covered by the spillage test. The appliance is dried between each test.*

<https://standards.iteh.ai/catalog/standards/sist/0da4b5fe-857b-44c3-8f64-10c2bf7c4c4/iec-60335-2-6-2014-amd1-2018>

The test is performed as follows:

A bottle with a shape similar to the one in Figure 107 and a cap is filled with 0,5 l of the spillage solution.

The cap of the bottle shall have a hole of 8 mm diameter, placed off-centre according to Figure 106. The bottle shall also have a hole of 8 mm diameter near the bottle base (see Figure 107) to equalize the liquid pressure.

Other suitable containers may be used provided the spillage solution amount is poured over the appliance under test in the same manner.

*The hole in the cap of the bottle is put on the horizontal work surface at approximately 80 mm horizontal distance with respect to the front of the **oven**. The inclination of the bottle shall be higher than 30° and lower than 45°. The lower part of the bottle hole in the cap shall be in contact with the work surface, with the hole in the cap placed down closest to the surface. See Figure 108.*

NOTE 101 The intention of the inclination and distance is avoiding the spillage “jumping” over the front of the **oven**.

NOTE 102 When using holes of 8 mm diameter, the specified solution amount is spilled in about 15s.

When the 0,5 l of spillage solution has been poured, the remaining solution on the work surface is pushed towards the front so that the remaining solution spills homogeneously over the front with a suitably flat means.

Steam generators intended to be connected to the water mains are supplied at **rated water pressure**. Control devices for the supply of water are held open. If more than one device is used, they are tested in turn. Water is allowed to flow for 1 min after the first evidence of overflow, unless the inflow stops automatically.

21 Mechanical strength

21.1 Add the following sentence to the third paragraph of the addition:

This test is carried out without removing any guard of the heating elements.

21.101 In the column "Side dimensions of vessels" in Table 105, replace the value 160 with 160 × 160 and the value 200 with 200 × 200.

22 Construction

22.102 Replace the existing text by the following:

22.102 **Remote operation** and timers intended to delay the operation of a heating element shall not control a **grill**, unless the **grill** is thermally controlled, incorporated in an **oven** or compartment and it is only possible to operate the **grill** with the door of the **oven** or compartment being closed. Delayed start timers shall not control a **hob element**.

Compliance is checked by inspection. However, if monitoring of the door is by a programmable **electronic circuit**, the software shall contain measures to control the fault/error conditions specified in Table R.1 and is evaluated in accordance with the relevant requirements in Annex R.

<https://standards.iteh.ai/catalog/standards/sist/0da4b5fe-857b-44c3-8f64-47c01e4e1cc6/iec-60335-2-6:2014/AMD1:2018>

22.122 Add the following text to the end of the first paragraph.

This requirement also does not apply to shelves that are designed to be used in **steam ovens**, having a depth lower than 320 mm and perforated to contain vegetables.

Add the following text to the end of the second paragraph:

"or 50 % of the depth of the shelf whichever is less".

Add after 22.137 the following new subclause:

22.138 For appliances that are controlled by programmable **electronic circuits** that limit the number of heating elements and motors from being energised at the same time, simultaneous activation of any combination of heating elements and motors shall not render the appliance unsafe.

Compliance is checked as follows:

- the fault/error conditions specified in Table R.1 are applied and evaluated in accordance with the relevant requirements of Annex R; or
- the appliance is operated under the conditions of Clause 11 while being supplied at **rated voltage**, the programmable **electronic circuits** being modified to allow simultaneous activation of all heaters and motors under their control. Under these conditions, compliance with 19.13 shall be fulfilled.

Figures

Add the following new figures:

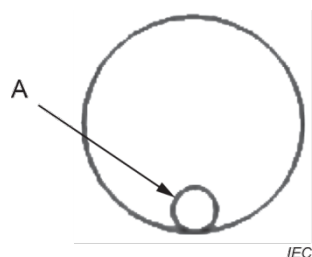

Key

A bottle cap hole – diameter 8 mm

Figure 106 – Detail of bottle cap and position of hole



iTeh STANDARD PREVIEW
(standards.iteh.ai)

<https://standards.iteh.ai/catalog/standards/sist/0da4b5fe-857b-44c3-8f64-486acbf7c4c4/iec-60335-2-6-2014-amd1-2018>

Key

A bottle hole with diameter 8 mm
B bottle cap

Figure 107 – Spillage solution bottle

Dimensions in millimetres

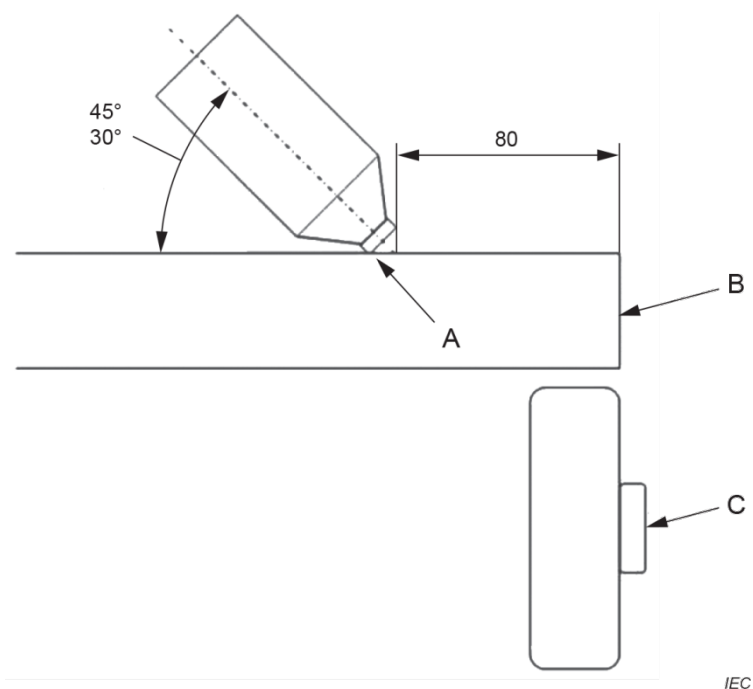

Key

- A bottle cap hole position
- B edge of work surface
- C front of oven

iTeh STANDARD PREVIEW
(standards.iteh.ai)

IEC 60335-2-6:2014/AMD1:2018
<http://standards.iteh.ai/catalog/standards/sist/60335-2-6-2014-amd1-2018>
486acbf7c4c4/iec-60335-2-6-2014-amd1-2018

Annex R – Software evaluation

R.2.2.5 Replace “22.123, 22.124, 22.134” by “22.102, 22.123, 22.124, 22.134, 22.138”.

R.2.2.9 Replace “22.123, 22.124, 22.134” by “22.102, 22.123, 22.124, 22.134, 22.138”.
