



Designation: C 1147 – 01

Standard Practice for Determining the Short Term Tensile Weld Strength of Chemical-Resistant Thermoplastics¹

This standard is issued under the fixed designation C 1147; the number immediately following the designation indicates the year of original adoption or, in the case of revision, the year of last revision. A number in parentheses indicates the year of last reapproval. A superscript epsilon (ϵ) indicates an editorial change since the last revision or reapproval.

1. Scope

1.1 This practice covers the preparation and evaluation of joints between two pieces of weldable grades of thermoplastic materials, backed and unbacked, (such as those shown in Table 1) up to 2 in. (50 mm) in thickness.

1.2 Since there are numerous new technologies and techniques constantly being developed for plastic welding, there are no profiles and procedures that can be considered as standard for all plastics at various thicknesses. This practice is not intended to define profiles and procedures; however, it is intended to establish methods to evaluate minimum short term weld factors to be achieved by the welder for the respective plastics.

1.3 Weld procedures used for test pieces should reflect procedures to be used in actual fabrication.

1.4 Welding methods to be used could include machine welding, extrusion welding, and hot gas welding.

1.5 The values stated in inch-pound units are to be regarded as the standard. The values given in parentheses are for information only.

2. Referenced Documents

2.1 ASTM Standards:

C 904 Terminology Relating to Chemical-Resistant Non-metallic Materials²

D 4285 Test Method for Indicating Oil or Water in Compressed Air³

E 4 Practices for Force Verification of Testing Machines⁴

3. Terminology

3.1 *Definitions*—For definitions of terms used in this practice, see Terminology C 904.

¹ This practice is under the jurisdiction of ASTM Committee C03 on Chemical-Resistant Nonmetallic Materials and is the direct responsibility of Subcommittee C03.03 on Thermoplastic Fabrications.

Current edition approved May 10, 2001. Published July 2001. Originally published as C 1147 – 90. Last previous edition C 1147 – 95.

² *Annual Book of ASTM Standards*, Vol 04.05.

³ *Annual Book of ASTM Standards*, Vol 06.02.

⁴ *Annual Book of ASTM Standards*, Vol 03.01.

TABLE 1 Typical Guide for Hot Gas Welding Temperatures

NOTE 1—For other welding techniques, consult material and equipment supplier for recommendations.

	°F ^A	Recommended Gas Type ^B
HDPE	500–600	Nitrogen or Air
PP	550–600	Nitrogen or Air
PVC	500–550	Air
CPVC	550–660	Air
PVDF	650–680	Nitrogen or Air
ECTFE	665–695	Nitrogen
ETFE	675–710	Air
FEP	650–725	Air
PFA	675–750	Air
MFA	536–554	Air

^A Measured 1/4 in. inside weld tip, directly in gas stream.

^B Inert gas may be used in place of air.

4. Summary of Practice

4.1 The sheets are prepared and welded. Tensile test specimens containing a section of the weld are prepared and tested. Specimens of unwelded sheet are tested and compared to the welded specimens. The short term weld factor determined is compared to the standard (see Table 2), or to the factor agreed upon between the supplier and the user.

5. Significance and Use

5.1 The mechanical performance of welded thermoplastic structures is largely dependent on the quality of the welding operation. Fabricators should determine that the proper welding procedures are being followed and that welders maintain their proficiency. Results from this practice are indicative of skill in proper welding procedures for different thermoplastic materials and the use of appropriate welding equipment. If the welded test specimens have short term weld factors that meet or exceed the minimums as set forth in this practice, or as agreed to by supplier and user, it may be concluded that, with the same degree of skill and diligence by the welder, acceptable welds should be obtained in fabricated structures.

6. Apparatus

6.1 The apparatus for welding shall consist of the following:

6.1.1 *Welding Device*, suitable for joining thermoplastics.

TABLE 2 Minimum Short Term Weld Factors

Thermoplastic	Hot Gas	Extrusion	Hot Plate
HDPE	0.8	0.8	0.9
PP	0.8	0.8	0.9
PVC	0.8	^A	0.9
CPVC	0.6	^A	0.8
PVDF	0.8	0.8	0.9
ECTFE	0.9	0.9	0.9
ETFE	0.9	0.9	0.9
FEP	0.9	0.9	0.9
TFE (PFA Filler)	0.9	0.9	^A
PFA	0.9	0.9	0.9

^A Not applicable.

6.1.2 *Air Supply*, when needed, conforming to Test Method D 4285.

6.1.3 *Temperature Measuring Device*, capable of measuring the welding temperature to within $\pm 1\%$ for the specific plastic as set forth in Table 1.

6.1.4 *Clamps*, suitable for holding the specimen while welding.

6.1.5 *Saw*, suitable for cutting thermoplastic sheet.

6.1.6 *Sander, Router, Joiner, or Saw*, suitable for beveling edges of sheet.

6.2 The apparatus for testing tension specimens shall consist of the following:

6.2.1 *Tensile Machine*—A testing machine capable of pulling the specimens at a rate of 2 ± 0.1 in./min (50 ± 2.5 mm/min) of crosshead movement (speed of movement when the machine is running without a load).

6.2.1.1 The rate of movement between heads of the testing machine shall remain essentially constant under changing loads (see Note 1).

NOTE 1—It is difficult to meet this requirement when loads are measured with a spring type or pendulum type weighing device.

6.2.1.2 The testing machine shall measure the load to within 1%. The testing range shall be so selected that the maximum load on the specimen falls between 15 and 85% of the full scale capacity.

6.2.1.3 The use of autographic equipment to record the load versus head movement is recommended.

6.2.1.4 Verification of the testing machine shall be made in accordance with the recommendations of Practices E 4.

6.2.2 *Micrometer or Vernier Caliper*, suitable for measuring width and thickness of the test specimen to the nearest 0.001 in. (0.025 mm).

7. Test Specimens

7.1 *Test Pieces For Hot Gas and Extrusion Welding*—Start with a 10 by 42 in. (250 by 1050 mm) piece of plastic sheet of the type and thickness to be tested. Cut the sheet as shown in Fig. 1 to yield five pieces, four measuring 5 by 18 in. (125 by 450 mm) and one measuring 6 by 10 in. (150 by 250 mm). Two 5 by 18 in. pieces will be used for horizontal welding and two 5 by 18 in. pieces for vertical welding.

7.1.1 The 6 by 10 in. sample will be cut into control specimens as described in Section 7.2.2. Label each piece as to type of plastic, method of welding, orientation of welding and welder identification.

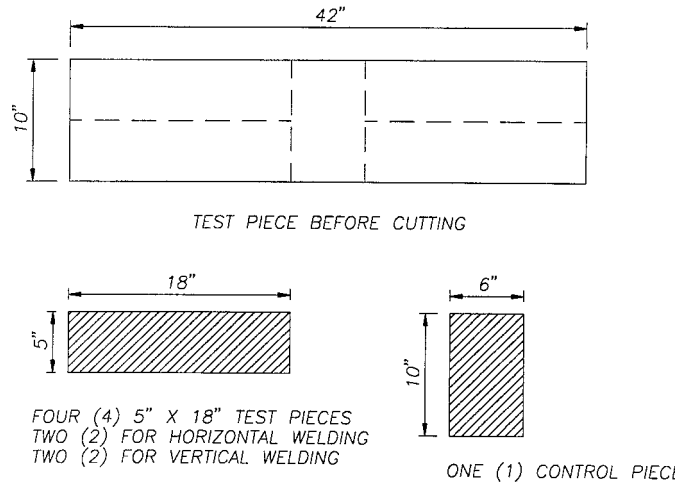
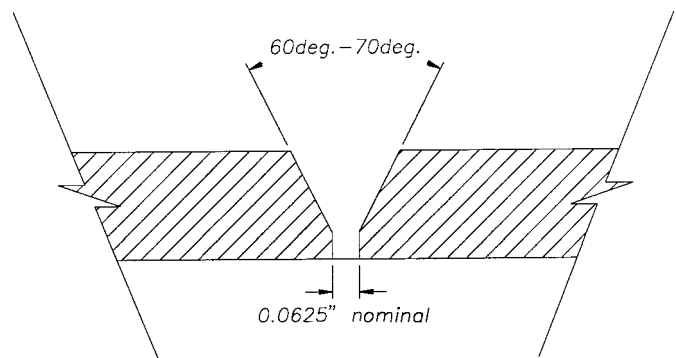

FIG. 1 Test Pieces

7.1.2 *Edge Preparation*—Bevel one 18 in. (450 mm) edge of each 5 by 18 in. piece in preparation for welding. Beveling shall be done using suitable apparatus such as routers, sanders, joiners, or saws, that accurately reflect methods utilized in the field. Typical bevel profiles for the various sheet thicknesses are illustrated in Fig. 2 and Fig. 3. These profiles are optional and do not have to be used by the fabricator to meet the weld test standard, however, experience has shown that the use of beveled edges is advantageous to weld quality in sheet greater than 60 mils (1.5 mm) in thickness in hot gas and extrusion welding processes. Do not use solvents or other chemicals for cleaning the beveled surfaces that in any way will adversely affect the properties of the plastic. The cleaning operation should not in any way alter the profile or bevel of the edge. Details of bevels and test procedures used should accompany test specimens and the report of test results.

7.1.3 *Welding Procedure*—Securely clamp the test sheets to be welded to a suitable fixture and adjust welding device temperature as specified in Table 1. Weld two specimens, one vertically to simulate tank walls, and one horizontally to simulate tank floors. If a machine such as a hot plate welder or other equipment that is in a fixed position is being used, the two test specimens, cut and configured as in 7.1, are welded in



NOTE: Sheet width between 0.09" (2.3mm) to 0.5" (13mm) in thickness.

FIG. 2 Typical Bevel Profile (Sheet >0.090 to 0.5 in. (2.3 mm to 13 mm) in Thickness)