



Designation: D 4707 – 97 (Reapproved 2003)^{ε1}

Standard Test Method for Measuring Paint Spatter Resistance During Roller Application¹

This standard is issued under the fixed designation D 4707; the number immediately following the designation indicates the year of original adoption or, in the case of revision, the year of last revision. A number in parentheses indicates the year of last reapproval. A superscript epsilon (ε) indicates an editorial change since the last revision or reapproval.

^{ε1} NOTE—Typos editorially corrected in January 2003.

1. Scope

1.1 This test method covers the determination of the tendency of a paint to spatter when applied with a paint roller to a substrate.

1.2 *This standard does not purport to address all of the safety concerns, if any, associated with its use. It is the responsibility of the user of this standard to establish appropriate safety and health practices and determine the applicability of regulatory limitations prior to use.*

2. Referenced Documents

2.1 ASTM Standards:

D 3924 Specification for Standard Environment for Conditioning and Testing Paint, Varnish, Lacquer, and Related Materials²

D 3925 Practice for Sampling Liquid Paints and Related Pigmented Coatings²

2.2 Other Document:

Pictorial Standards of Paint Roller Spatter³

3. Summary of Test Method

3.1 The test paint is applied to a black plastic panel by draw-down. The coated plastic panel is immediately mounted on an essentially vertical surface above a sheet of paper used to catch any spatter. A specially designed notched spool roller (see 5.1) is rolled through the film following a defined procedure, tending to generate spatter. Any spatter falls upon the spatter catch paper and, after drying, is rated against the pictorial standards.

¹ This test method is under the jurisdiction of ASTM Committee D01 on Paint and Related Coatings, Materials, and Applications and is the direct responsibility of Subcommittee D01.42 on Architectural Coatings.

Current edition approved Jan. 10, 2003. Published March 2003. Originally approved in 1987. Last previous edition approved in 1997 as D 4707 - 97.

² *Annual Book of ASTM Standards*, Vol 06.01.

³ Copies of the pictorial photographic reference standards are contained in *Pictorial Standards of Coatings Defects* and may be obtained from the Federation of Societies For Coatings Technology, 492 Norristown Rd., Blue Bell, PA 19422.

4. Significance and Use

4.1 Paint spatter generated by roller application is dependent on the properties of both the paint being applied and the paint roller cover used for the application. To eliminate the influence of the paint roller cover as a variable, and thus restrict the spatter-inducing variable to the paint under test only, the paint roller cover is replaced by a standard notched spool roller to generate spatter by a mechanism that simulates that of a paint-applying roller cover.

4.2 Although most of the development work to establish this test method was undertaken using latex paints, sufficient work was also done to show its applicability to solvent-reducible paints.

4.3 Tests during the development of this test method showed that the spattering properties of paints, like other physical properties, may in time change. Therefore, the results of this test are valid only for the time when the test is run.

5. Apparatus

5.1 *Notched Spool Test Roller* (Fig. 1).⁴

5.2 *Glass Plate*, at least 9 by 19 in. (230 by 485 mm) by ¼ in. (6 mm) thick.

5.3 *U-shaped Film Caster*,⁵ having a 7-mil (175-μm) clearance by 5¼ in. (135 mm) wide.

5.4 *Mechanical Metronome*, with swinging arm adjusted to 80 beats per min..

⁴ The sole source of supply of the notched spool test roller known to the committee at this time is Precision Gage and Tool Co., 28 Volkenand Ave., Dayton, OH 45410. If you are aware of alternative suppliers, please provide this information to ASTM International Headquarters. Your comments will receive careful consideration at a meeting of the responsible technical committee,⁴ which you may attend.

⁵ The sole source of supply of the Dow film canister known to the committee at this time is BYK-Gardner, Inc., Gardner Laboratory, 2435 Linden Lane, Silver Spring, MD 20910. If you are aware of alternative suppliers, please provide this information to ASTM International Headquarters. Your comments will receive careful consideration at a meeting of the responsible technical committee,⁵ which you may attend.

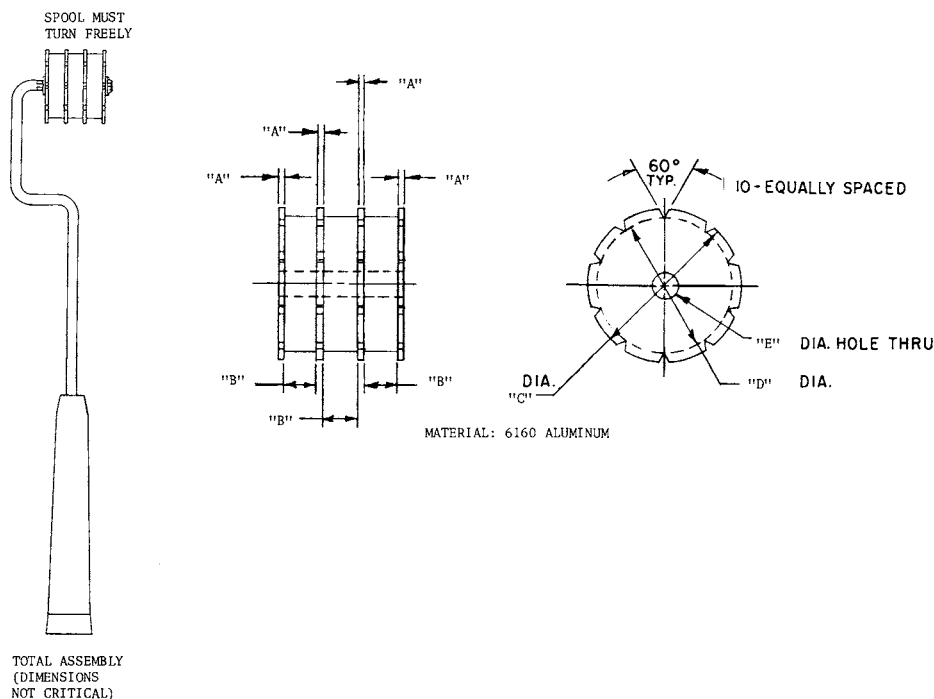

		Dimensions	
		in.	mm
A	Flange thickness	0.063 ± 0.005	1.60 ± 0.13
B	Space between flanges	0.343 ± 0.005	8.71 ± 0.13
C	Total diameter	1.600 ± 0.015	40.16 ± 0.38
D	Diameter under notches	1.400 ± 0.015	35.56 ± 0.38
E	Hole diameter	0.281 ± 0.005	7.14 ± 0.13

FIG. 1 Notched Pool Roller

6. Materials

- 6.1 Black Plastic Panels,⁶ 6½ by 17 in. (165 by 430 mm).
- 6.2 Flannel Cloth.
- 6.3 Masking Tape, 1 in. (25 mm) wide.
- 6.4 Spatter Catch Paper, 18 by 18 in. (455 by 455 mm).

This paper can be any convenient paper to which the spatter droplets will adhere and of a color to contrast that of the paint under test.

7. Sampling and Conditioning

7.1 Sample the material in accordance with Practice D 3925.

7.2 Prior to testing, the samples shall be conditioned in accordance with the standard atmosphere described in Specification D 3924. The testing shall take place under the same conditions.

8. Procedure

8.1 Clean the top of the glass plate and both sides of the black plastic panel to ensure that they are free of specks. Place the black plastic panel on the glass plate and tape the narrow end at the top to the glass plate. Smooth the panel along the plate to ensure a close fit.

8.2 Stir the paint under test thoroughly and strain to remove all skins and particles. Place the film caster with the 7.0-mil (175-µm) side down immediately below the taped portion of the black plastic panel. Turn on the metronome. Into the well formed by the film caster, pour sufficient paint that the well is filled from corner to corner. Draw down the paint the full length of the black plastic panel until the film caster is fully beyond the far edge. The rate of application should be fairly slow, 3 to 4 s. from end to end, to prevent pinholes or holidays in the paint film.

8.3 Immediately upon completion of the draw-down, remove the black plastic panel from the glass plate, keeping the masking tape intact, and tape, with the long direction vertical to a surface that is vertical or nearly vertical (within 5° of vertical, top sloping away from the operator) with the bottom of the black plastic panel about 1 in. (25 mm) above the laboratory bench or table (Fig. 2). It is desirable that the surface under the black plastic panel be firm but with a little resilience.

⁶ The sole source of supply of the dull black plastic panels, Leneta P-121-10N, 6½ by 17 in. by 10 mil (production tolerance ±1 mil) (165 by 430 by 250 µm) in size known to the committee at this time is Leneta Company, 15 Whitney Rd., Mahwah, NJ 07430. If you are aware of alternative suppliers, please provide this information to ASTM International Headquarters. Your comments will receive careful consideration at a meeting of the responsible technical committee,¹ which you may attend.

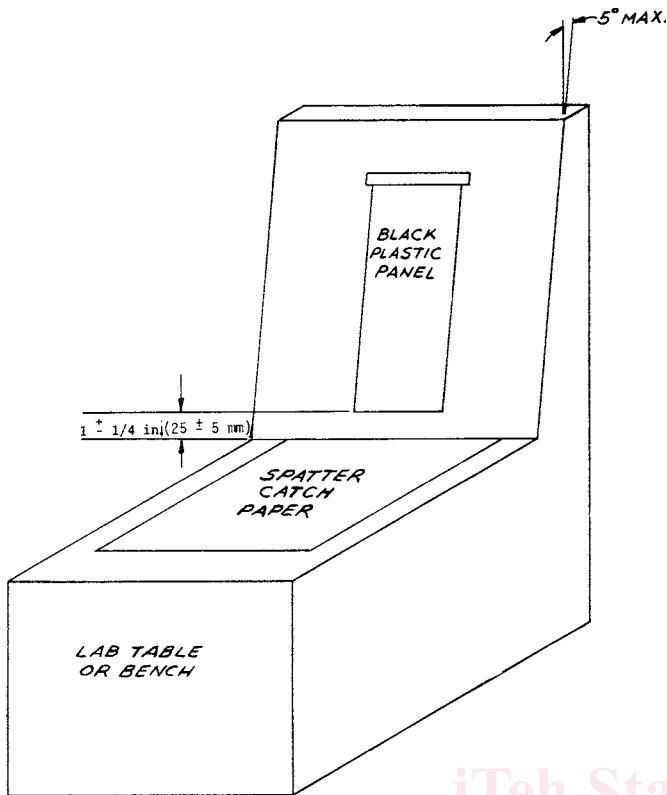
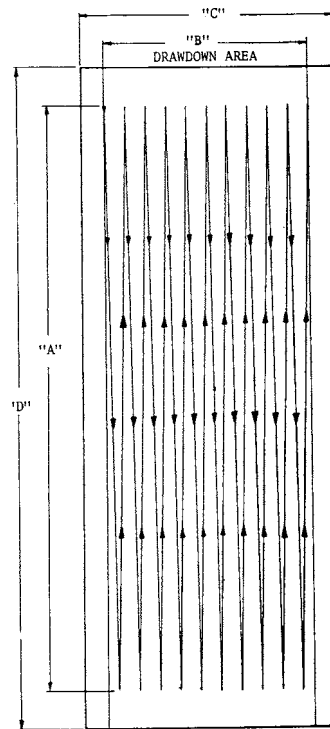

FIG. 2 Test Set-Up Schematic

A backing of 1/4-in. (6-mm) thick fiberboard is ideal as very hard surfaces make proper performance of the test difficult. Center the spatter catch paper on the laboratory bench or table under the black plastic panel.

8.4 Using the clean, notched spool roller, start in one of the upper corners and roll downward and upward through the paint film. Always keep the notched spool in contact with the black plastic panel, not removing the roller from the film when changing directions. Make ten passes in each direction (20 passes total), $15 \pm \frac{1}{2}$ in. (380 ± 15 mm) per pass, progressively moving sideways from one edge of the film to the other (Fig. 3). Each pass should coincide with a beat of the metronome and the motion should be continuous, not jerky. Try to emulate the motion of the metronome, using the metronome for accurate timing (practice the motion with the metronome to gain the necessary rhythm and timing), since the speed of the rolling of the notched spool roller through the paint film has been found to be the only variable significantly affecting the results of the test. Make sure that all four flanges of the notched spool roller are within the draw-down area at all times. Use sufficient pressure to maintain constant contact between the notched spool roller and the black plastic panel. Note that as long as constant contact is maintained, pressure variations have not been found to affect the results noticeably.

8.5 Remove the spatter catch paper and lay it in a suitable place to dry.



Dimensions			
		in.	mm
A	Notched spool pass length	$15 \pm \frac{1}{2}$	380 ± 15
B	Drawdown width (determined by blade)	$5\frac{1}{4}$	140
C	Panel width	$6\frac{1}{2}$	165
D	Panel length	17	430

FIG. 3 Test Pattern Schematic

8.6 Repeat the test with a second plastic panel after cleaning the apparatus.

9. Grading Procedure

9.1 Carefully cut an area $7\frac{1}{2}$ by $9\frac{1}{2}$ in. (190 by 240 mm) out of the front edge (edge nearest the paint) of the spatter catch paper. The $7\frac{1}{2}$ -in. side will be the front edge. Center the area with respect to the spatter so a maximum of spatter is on this sheet (Fig. 4).

9.2 Compare the cut-out area to the pictorial standards. Assign the rating that most closely matches a standard, interpolating as needed for ratings (0—poor spatter resistance, 2, 4, 6, 8, and 10—no spatter).

NOTE 1—Figs. 5-9 are duplications thereof for sample purposes and are not meant to be used for test grading purposes.

9.3 In rating the paints using the photographic standards, consider the population of spatter droplets of greater importance than the average size of the spatter droplets.

9.4 If the ratings of two tests do not agree within 1 unit, repeat until such precision is obtained.

FRONT (Edge nearest to the mounted panel during test.)

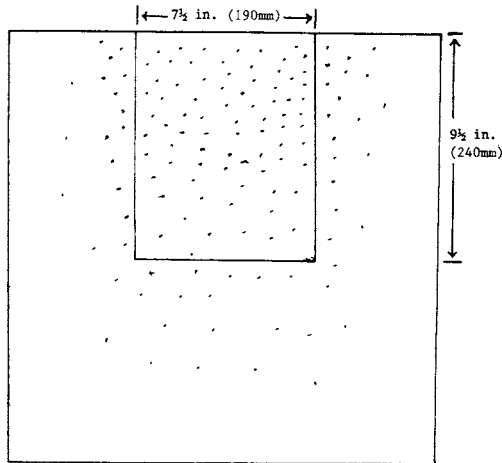

FIG. 4 Cutting Out Section of Spatter Catch paper for Evaluation

one laboratory tested only two paints, the between-laboratories standard deviation was found to be 0.17 rating units (see Note 2) with 18 df, with no results discarded. Based on this standard deviation, the following criteria should be used for judging the acceptability of results at the 95 % confidence level:

10.1.1 *Repeatability*—Intralaboratory precision is normally better than interlaboratory precision. However, when rating is involved, it is difficult to establish reliability because of the natural tendency for bias when operators know the same material is being tested again.

NOTE 2—When the results were ranked, the agreement among the six operators was perfect. This might not occur if some paints with less distinct differences in spattering properties were included in a similar study.

10.1.2 *Reproducibility*—Two results obtained by operators in different laboratories should be considered suspect if they differ by more than 0.5 units.

10.2 *Bias*—Bias can not be determined for this test method because there is no standard reference material.

10. Precision and Bias

10.1 In an interlaboratory study of this test method in which one operator in each of three laboratories tested six paints with a broad range in spattering properties, one operator in two other laboratories tested three of the paints and one operator in

11. Keywords

11.1 paint spatter resistance; resistance—paint spatter; roller application; spattering

iTeh Standards
(<https://standards.itih.ai>)
Document Preview

[ASTM D4707-97\(2003\)e1](https://standards.itih.ai/catalog/standards/sist/3676160e-683c-448c-8631-7a46fb3419ac/astm-d4707-972003e1)

<https://standards.itih.ai/catalog/standards/sist/3676160e-683c-448c-8631-7a46fb3419ac/astm-d4707-972003e1>



FIG. 5 Paint Spatter Resistance to Roller Application Rating Standard No. 1

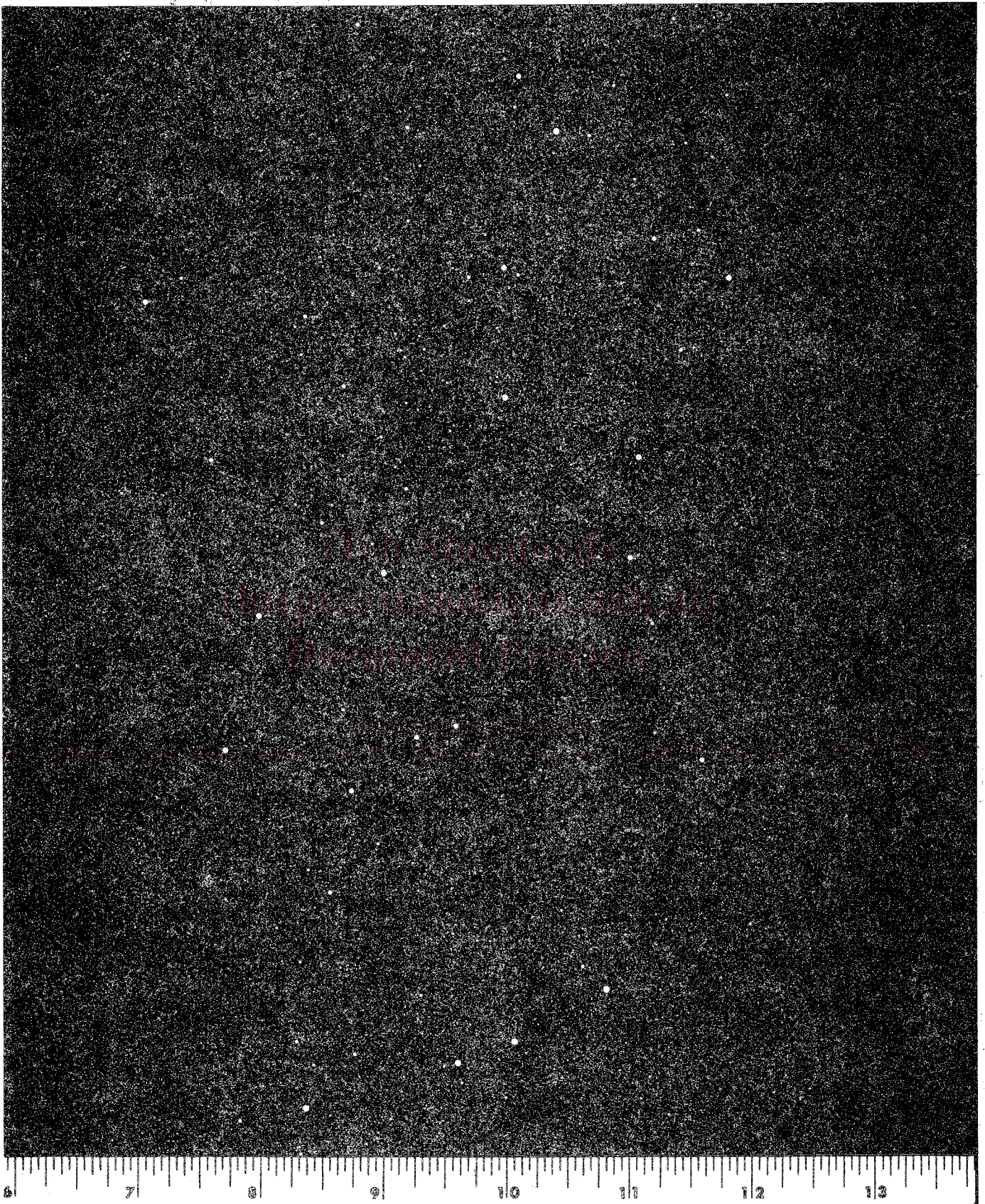

FIG. 6 Paint Spatter Resistance to Roller Application Rating Standard No. 3