



Designation: D 850 – 03

Standard Test Method for Distillation of Industrial Aromatic Hydrocarbons and Related Materials¹

This standard is issued under the fixed designation D 850; the number immediately following the designation indicates the year of original adoption or, in the case of revision, the year of last revision. A number in parentheses indicates the year of last reapproval. A superscript epsilon (ϵ) indicates an editorial change since the last revision or reapproval.

This standard has been approved for use by agencies of the Department of Defense.

1. Scope *

1.1 This test method covers the distillation of industrial aromatic hydrocarbons and related materials of relatively narrow boiling ranges from 30 to 250°C.

1.2 The values stated in SI units are to be regarded as the standard. The values given in parentheses are for information only.

1.3 The following applies to all specified limits in this test method: for the purposes of determining conformance to this test method, an observed or calculated value shall be rounded off “to the nearest unit” in the last right-hand digit used in expressing the specification limit, in accordance with the rounding-off method of Practice E 29.

1.4 *This standard does not purport to address all of the safety concerns, if any, associated with its use. It is the responsibility of the user of this standard to establish appropriate safety and health practices and determine the applicability of regulatory limitations prior to use.* For specific hazard statements, 6.6.1 and Section 7.

2. Referenced Documents

2.1 ASTM Standards:

D 1078 Test Method for Distillation Range of Volatile Organic Liquids²

D 3437 Practice for Sampling and Handling Liquid Cyclic Products²

D 4790 Terminology of Aromatic Hydrocarbons and Related Chemicals²

E 1 Specification for ASTM Thermometers³

E 29 Practice for Using Significant Digits in Test Data to Determine Conformance with Specifications⁴

E 133 Specification for Distillation Equipment⁵

E 220 Test Method for Calibration of Thermocouples by Comparison Techniques³

E 691 Practice for Conducting an Interlaboratory Study to Determine the Precision of a Test Method⁴

2.2 Other Document:

OSHA Regulations, 29 CFR, paragraphs 1910.1000 and 1910.1200⁶

3. Terminology

3.1 Definitions:

3.1.1 See Terminology D 4790 for definitions of terms used in this test method.

4. Summary of Test Method

4.1 The distillation of a 100-mL sample of industrial aromatic hydrocarbons and related materials is carried out via a carefully controlled distillation wherein temperature readings are noted for the first drop of distillate and when 5, 10, and each additional 10 up to 90, and 95 % of the sample has distilled over. The temperature corresponding to the dry point is also noted.

5. Significance and Use

5.1 This test method is suitable for setting specifications, for use as an internal quality control tool, and for use in development or research work on industrial aromatic hydrocarbons and related materials.

5.2 This test method gives a broad indication of general purity and can also indicate presence of excessive moisture. It will not differentiate between products of similar boiling range.

6. Apparatus

6.1 *Distillation Flask*—A standard 200-mL side-tube, heat-resistant glass distillation flask as shown in Fig. 1, conforming to the following dimensions:

¹ This test method is under the jurisdiction of ASTM Committee D16 on Aromatic Hydrocarbons and Related Chemicals and is the direct responsibility of Subcommittee D16.04 on Instrumental Analysis.

Current edition approved Jan. 10, 2003. Published March 2003. Originally approved in 1945. Last previous edition approved in 2002 as D 850 – 02^{ε1}.

² *Annual Book of ASTM Standards*, Vol 06.04.

³ *Annual Book of ASTM Standards*, Vol 14.03.

⁴ *Annual Book of ASTM Standards*, Vol 14.02.

⁵ *Annual Book of ASTM Standards*, Vol 14.04.

⁶ Available from Superintendent of Documents, U.S. Government Printing Office, Washington, DC 20402.

*A Summary of Changes section appears at the end of this standard.

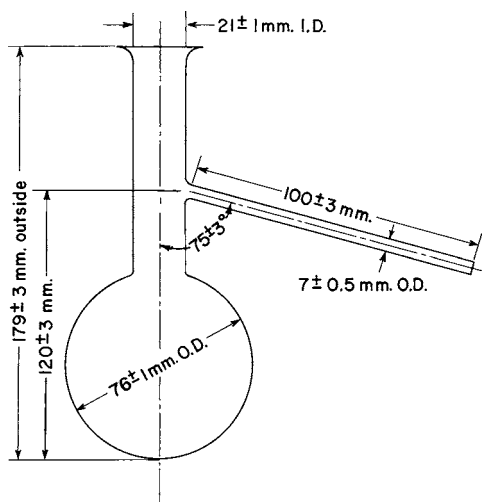

FIG. 1 Distillation Flask

| | |
|---|----------|
| Diameter of bulb, outside, mm | 76 ± 1.5 |
| Diameter of neck, inside, mm | 21 ± 1 |
| Height of flask, outside, mm | 179 ± 3 |
| Vertical distance from bottom of bulb outside to bottom of vapor-tube opening in neck, mm | 120 ± 3 |
| Length of side tube, mm | 100 ± 3 |
| Diameter of side tube, outside, mm | 7 ± 0.5 |
| Angle of side tube with vertical axis of bulb and neck, ° | 75 ± 3 |

The flask does not comply with Flask C of Specification E 133.

6.2 Temperature Measurement Devices:

6.2.1 *Manual Distillation Thermometer*—The ASTM Solvents Distillation Thermometer used in the test shall be as prescribed in the specifications for the material being tested. If no thermometer is specified in the material specification, select one from Table 1 with the smallest graduations that will cover the entire distillation range of the material being tested. Table 1 lists several ASTM solvents distillation thermometers which are suitable for testing industrial aromatic hydrocarbons, and which meet the requirements of Specification E 1.

6.2.2 *Automatic Distillation Temperature Sensor*—Temperature measurement systems using thermocouples or resistance thermometers, otherwise referred to as the “temperature measuring devices,” must exhibit the same temperature lag and accuracy as the equivalent mercury glass thermometer. Confirmation of the calibration of these temperature sensors is to be done at regular intervals. This may be accomplished as

prescribed in Test Method E 220, or some similar means using a precision resistance decade box. Another technique is to distill pure toluene and compare the temperature indicated by the thermocouple or resistance thermometer with that shown by the thermometer. When installing a new automatic distillation analyzer, a toluene sample with a known distillation range of approximately 1.0°C must be used to verify the dry point and distillation range.⁷ It is recommended that such a material be used when replacing a temperature measuring device. Alternatively a material of known distillation range and dry point may be used when replacing a temperature measuring device.

6.2.2.1 *Automatic Distillation Temperature Sensor Centering Device*—The temperature sensor shall be mounted through a snug-fitting device designed to mechanically center the sensor in the neck of the flask. The use of a cork or silicone stopper with a hole drilled through the center is not acceptable for this purpose. Examples of acceptable centering devices are shown in Fig. 2.

6.2.2.2 The electronic circuitry or algorithms, or both, used shall include the capability to simulate the temperature lag of a mercury-in-glass thermometer. For that reason the known toluene sample with a distillation range of approximately 1.0°C must be used to verify the algorithm and dampening software.

6.2.2.3 Alternatively, the sensor can also be placed in a casing with the tip of the sensor covered, so that the assembly, because of its adjusted thermal mass and conductivity, has a temperature lag similar to that of a mercury-in-glass thermometer.

NOTE 1—In a region where the temperature is changing rapidly during the distillation, the temperature lag of a thermometer can be as much as 3 s.

6.3 Condenser and Cooling Bath:

6.3.1 *Manual Distillation Condenser and Cooling Bath:*

6.3.1.1 The manual distillation condenser and cooling bath shall be as specified in Section 5, and Fig. 1 of Specification E 133.

6.3.1.2 As an alternative, the condenser tube may consist of a straight glass tube 600 to 610 mm in length and 12 mm in inside diameter, of standard wall thickness (about 1.25 mm) with the exit end cut off square and ground flat. It shall be set in a cooling trough so that at least 380 mm of the tube is in contact with the water. Clearance between the condenser tube and any parallel side of the trough shall be not less than 19 mm. The water in the cooling trough shall be maintained at 10 to 20°C. This may be done by adding ice to the water or by circulating chilled water through the trough. The trough shall be so mounted that the condenser tube is set at an angle of 75° with the vertical.

6.3.2 *Automatic Distillation and Cooling Bath*—The automatic distillation and cooling bath shall be as specified in Section 5, Fig. 2 of Specification E 133.

6.4 *Distillation Receiver:*

6.4.1 *Manual Distillation Receiver*—A graduate of the cylindrical type, of uniform diameter, with a pressed or molded

TABLE 1 ASTM Thermometers for Distillation Test of Industrial Aromatic Hydrocarbons

| ASTM Thermometer No. | Name | Range, °C | Subdivision, °C |
|----------------------|-----------------------|------------|-----------------|
| 39C | solvents distillation | 48 to 102 | 0.2 |
| 40C | solvents distillation | 72 to 126 | 0.2 |
| 41C | solvents distillation | 98 to 152 | 0.2 |
| 42C | solvents distillation | 95 to 255 | 0.5 |
| 102C | solvents distillation | 123 to 177 | 0.2 |
| 103C | solvents distillation | 148 to 202 | 0.2 |
| 104C | solvents distillation | 173 to 227 | 0.2 |
| 105C | solvents distillation | 198 to 252 | 0.2 |

⁷ Such a material is available from Spectrum Quality Standards.

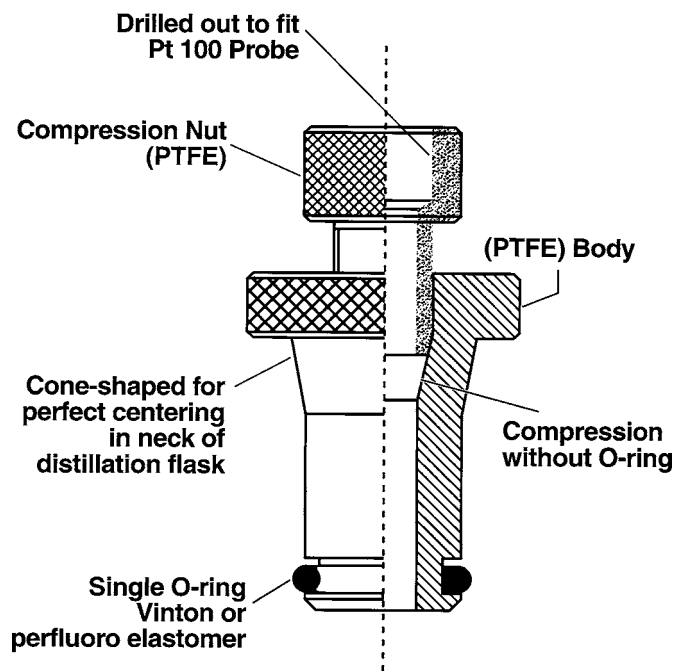

FIG. 2 Examples of Centering Device Designs for Straight-Bore Neck Flasks

base and a lipped top. The cylinder shall be marked to contain 100 mL, and the 0 to 100 mL receiver portion shall be not less than 178 nor more than 203 mm in length. It shall be graduated in single millilitres and each fifth mark shall be distinguished by a longer line. It shall be numbered from the bottom up at intervals of 10 mL. The overall height of the receiver shall not be less than 248 nor more than 260 mm. The graduations shall not be in error by more than 1 mL at any point on the scale. The bottom 1-mL graduation may be omitted. The receiver complies with Section 9, Graduate B Fig. 4, of Specification E 133.

6.4.2 *Automatic Distillation Receiver*—A receiver to be used with measurements in accordance with the instrument manufacturer and conform to the physical specifications described in this section, with the exception of the graduations.

6.4.2.1 *Automatic Distillation Level Follower*—For automatic apparatus, the level follower or recording mechanism of the apparatus will have a resolution of 0.1 mL with an accuracy of ± 1 mL. The calibration of the assembly should be confirmed according to the manufacturer's instructions at regular intervals. The typical calibration procedure involves verifying the output with the receiver containing 5 and 100 mL of material respectively.

6.5 *Flask Support Assembly:*

6.5.1 *For Units Using Electric Heaters*—The assembly consists of an adjustable system onto which the electric heater is mounted with provision for placement of a flask support board (see 6.5.2) above the electric heater. The whole assembly is adjustable from the outside of the shield.

6.5.2 *Flask Support Board*—The flask support board shall be constructed of ceramic or other heat-resistant material with a centrally located opening. For tests of benzene and toluene, the opening shall be 25 mm in diameter; for tests of materials boiling above toluene but mostly below 145°C, the opening shall be 38 mm in diameter, and for higher boiling materials, it

shall be 50 mm in diameter. The flask support board shall be of sufficient dimension to ensure that thermal heat to the flask only comes from the central opening and that extraneous heat to the flask other than through the central opening is minimized. (**Warning**—Asbestos-containing materials shall not be used in the construction of the flask support board.)

6.5.3 *For Units Using Bunsen Burner*—The flask support board is approximately 50 mm higher than the top of the burner.

6.6 *Heater:*

6.6.1 *Manual Distillation Heater*—An electric heater or a bunsen burner, fully adjustable and capable of giving sufficient heat to distill the product at the required rate. When a bunsen burner is used, as described in 7.1 and Fig. 1 of Specification E 133, the burner shall be adjusted so as to produce an entirely blue flame. (**Warning**—Superheating of the flask can cause erroneous results and is more likely to occur with electric heaters than with bunsen burners as heat sources. This problem is discussed in the section on Preparation of Apparatus in Test Method D 1078.)

7. **Hazards**

7.1 Consult current OSHA regulations and supplier's Material Safety Data Sheets, and local regulations, for all materials used in this test method.

8. **Sampling**

8.1 Sampling should follow safe rules in order to adhere to all safety precautions as outlined in the latest OSHA regulations. Refer to Practice D 3437 for proper sampling and handling of aromatic hydrocarbons analyzed by this test method.