



Designation: D 6846 – 02

Standard Practice for Preparing Prints of Paste Printing Inks with a Printing Gage¹

This standard is issued under the fixed designation D 6846; the number immediately following the designation indicates the year of original adoption or, in the case of revision, the year of last revision. A number in parentheses indicates the year of last approval. A superscript epsilon (ϵ) indicates an editorial change since the last revision or reapproval.

1. Scope

1.1 This practice covers the procedure for preparing laboratory prints of paste inks using a printing gage in conjunction with a flat-bed proof press.

1.2 This practice is applicable to the preparation of solid-area prints by direct letterpress or by dry offset on a flat substrate such as paper, paperboard, or metal.

1.3 This practice is applicable primarily to lithographic and letterpress inks that dry by oxidation or penetration. With the addition of appropriate drying or curing equipment, it is also applicable to other paste ink systems such as heat-set or energy-curable.

1.4 The instructions in this practice are intended to minimize the within-print and among-operator variability inherent in hand operations.

1.5 This practice features built-in ink film thickness control. It does not measure the film thickness transferred to the print; however, film thickness equivalence may be evaluated by visual or instrumental comparisons of optical density.

1.6 Values stated in SI units are to be regarded as the standard. The values given in parentheses are for information only.

1.7 *This standard does not purport to address all of the safety concerns, if any, associated with its use. It is the responsibility of the user of this standard to establish appropriate safety and health practices and determine the applicability of regulatory limitations prior to use.* Specific precautions are given in Section 7.

2. Referenced Documents

2.1 ASTM Standards:

D 1316 Test Method for Fineness of Grind of Printing Inks by the NPIRI Grindometer²

D 6073 Test Method for Relative Setting of Heatset Printing Inks by the Sinvatrol Tester²

D 6487 Practice for Preparing Prints of Paste Printing Inks with an Offset Color Proofing Press²

3. Summary of Practice

3.1 The printing gage is inked by a drawdown technique; a double drawdown is recommended to minimize scratches and improve print appearance.

3.2 The inked gage is placed in the bed of the proof press from which the regular printing plate has been removed.

3.3 To make a letterpress print, the appropriate stock is attached to the impression (blanket) cylinder, which is rolled once over the inked gage. To make a dry offset print, the stock is clipped onto the impression plate and the blanket cylinder is rolled over the inked printing gage two to four times followed by once over the stock.

3.4 Two-color prints may be prepared by utilizing two inked gages in the bed of an offset proofing press.

4. Significance and Use

4.1 Laboratory proofing of inks is necessary to establish a reproducible prediction of print appearance and performance properties, most of which are highly sensitive to ink film thickness. The apparatus described in this practice has found wide use for routine control proofing because it provides an economical method for producing reasonably large prints at film thicknesses comparable to those obtained on production presses.

4.2 A unique advantage of printing gages is that, depending on the design selected, prints can be produced at a range of tapered film thicknesses or at several levels of uniform thicknesses in a single proofing. Because of the built-in film thickness control, ink metering is not necessary. Relatively small quantities of test samples are used, and less than two minutes are required to ink a gage, pull a letterpress print, and clean up. In addition, problems due to ink distribution systems are eliminated, two inks may be proofed at the same time, and multi-color printing is possible.

¹ This practice is under the jurisdiction of ASTM Committee D01 on Paint and Related Coatings, Materials and Applications and is the direct responsibility of Subcommittee D01.56 on Printing Inks.

Current edition approved Dec. 10, 2002. Published February 2003.

² *Annual Book of ASTM Standards*, Vol 06.02.

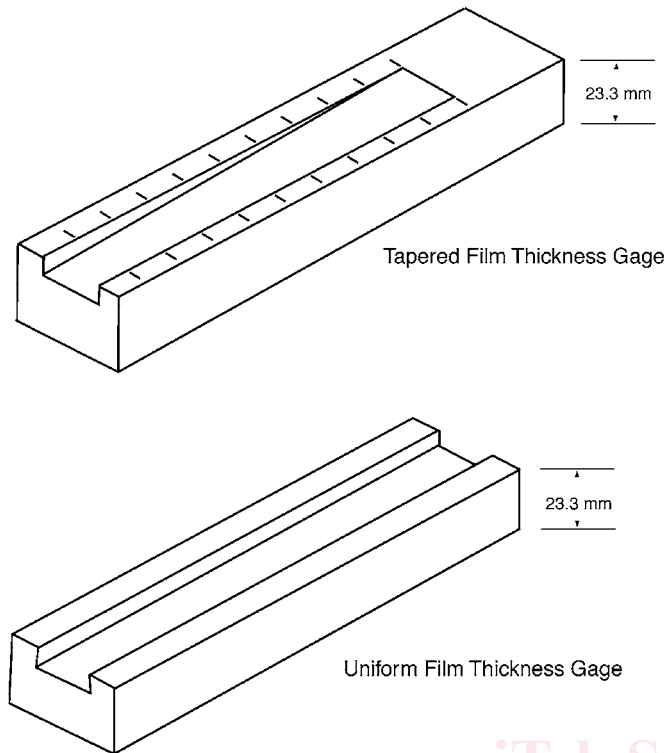

FIG. 1 Schematic Diagram of Printing Gages (not drawn to scale)

4.3 This practice does not duplicate the dynamics of a high speed press, nevertheless, it is useful for quality control and for specification acceptance between the producer and the user.

5. Apparatus

5.1 *Printing Gage*,³ consisting of a type-high (approximately 23.3 mm, 0.918 in.) block of steel, the top surface of which contains precision-machined channels that may be tapered in depth similar in principle to the grind gages described in Test Method D 1316. Alternatively, the channels may be uniform in depth at one or more levels. See Fig. 1 for schematic diagrams of the two types of gages. A description of popular models is given in Table 1.

5.2 *Drawdown Blade*,³ having a length sufficient to span the width of the printing gage being used.

5.3 *Flat Bed Proof Press*, with a bed wide enough to accommodate the printing gage. If proofing by dry offset is specified, the cylinder of the press must be capable of making two revolutions down the length of the bed, as in Practice D 6487.

5.4 *Ink Knife*, small.

5.5 *Accelerated Drying Equipment (Optional)*, for example, source of heat as in Test Method D 6073 or energy-curing, as appropriate to the system.

³ The sole source of supply of the apparatus known to the committee at this time is Precision Gage and Tool Co., 375 Gargrave Rd., Dayton, Oh 45449. If you are aware of alternative suppliers, please provide this information to ASTM International Headquarters. Your comments will receive careful consideration at a meeting of the responsible technical committee¹, which you may attend.

TABLE 1 Popular Models of Printing Gages^A

Model	Number of Paths	Dimensions of Each Path mm	Dimensions of Gage Top mm	Ink Film Thickness		
				Machined mils	Calibrated ^B µm	Calibrated ^B µm
<i>Tapered Film Thickness</i>						
NPIRI-A ^C	2	25 × 159	89 × 241	0-1.0	0-25	0-20
NPIRI-B	2	38 × 159	114 × 241	0-0.6	0-15	0-12
<i>Uniform Film Thickness, Single Depth</i>						
Warren-2	1	76 × 165 ^D	102 × 165 ^D	0.3	7½	6
Warren-3	1	76 × 165 ^D	102 × 165 ^D	0.4	10	8
Warren-4	1	76 × 165 ^D	102 × 165 ^D	0.5	12½	10
Warren-5	1	76 × 165 ^D	102 × 165 ^D	0.6	15	12
Huber-2	1	63 × 152	89 × 152	0.8	20	16
BSI-10	2	51 × 165 ^E	140 × 165 ^E	0.4	10	8
Lindner	2	51 × 165 ^E	140 × 165 ^E	0.6	15	12
<i>Uniform Film Thickness, Three Depths^F</i>						
FPBAA-C	3	38 × 102	165 × 102	0.2	5	4
				0.4	10	8
				0.6	15	12
6960-1	3	38 × 102	165 × 102	0.2	5	4
				0.3	7½	6
				0.4	10	8
6960-2	3	38 × 102	164 × 102	0.5	12½	10
				0.6	15	12
				0.7	17½	14
<i>Combination Uniform and Tapered Film Thickness</i>						
6401	2	51 × 203	153 × 203	0.6	15	12
		51 × 159		0-0.6	0-15	0-12

^A All models have paths ca. 23.3 mm (0.918 in.) high, parallel to bottom face.

^B Calibrated microns listed are based on 80 % path fillage for normal paste inks. Fillage for thinner inks is less.

^C This model serves as a type-high grindometer in Test Method D 1316.

^D Also available in a 190 mm length.

^E Also available in a 203 mm length.

^F Each path has a uniform depth, but the depth is different in each path. Any other combination may be ordered.

5.6 *Print Quality Measuring Equipment (Optional)*, as described in Practice D 6487 or as agreed upon between producer and user.

6. Materials

6.1 *Reference Standard (Optional)*, such as an ink sample, reference print, or a target level of quality attribute.

6.2 *Printing Substrate*, cut to slightly more than the dimensions of the gage top cited in Table 1.

6.3 *Shim Stock*, metal or plastic, the same size as the printing gage and 0.5 or 1 mil in thickness.

6.4 *Wash-up Materials*, including lint-free rags or tissue and an appropriate solvent.

6.5 *Grease*, to protect top face of printing gage when not in use.

7. Hazards

7.1 **Warning**—Since solvents may be hazardous to the skin and eyes, wear rubber gloves and safety glasses during cleanup to avoid solvent contact with skin and eyes. In case of contact, wash skin with water; flush eyes for 15 min with water and call a physician. See supplier’s Material Safety Data Sheets for further information on each solvent used.

7.2 *Equipment Cautions:*

7.2.1 Avoid any operation that will scratch or damage the printing gage and the blade. Refer to Test Method D 1316 for their care and for checking wear on the blade.