

# INTERNATIONAL STANDARD

## NORME INTERNATIONALE

**Insulating liquids – Determination of the breakdown voltage at power frequency – Test method**

**(standards.iteh.ai)**

**Isolants liquides – Détermination de la tension de claquage à fréquence industrielle – Méthode d'essai**

<https://standards.iteh.ai/catalog/standards/sist/34178fbc-bce5-44d2-ba89-28ab7fd00559/iec-60156-2018>



**THIS PUBLICATION IS COPYRIGHT PROTECTED**  
**Copyright © 2018 IEC, Geneva, Switzerland**

All rights reserved. Unless otherwise specified, no part of this publication may be reproduced or utilized in any form or by any means, electronic or mechanical, including photocopying and microfilm, without permission in writing from either IEC or IEC's member National Committee in the country of the requester. If you have any questions about IEC copyright or have an enquiry about obtaining additional rights to this publication, please contact the address below or your local IEC member National Committee for further information.

Droits de reproduction réservés. Sauf indication contraire, aucune partie de cette publication ne peut être reproduite ni utilisée sous quelque forme que ce soit et par aucun procédé, électronique ou mécanique, y compris la photocopie et les microfilms, sans l'accord écrit de l'IEC ou du Comité national de l'IEC du pays du demandeur. Si vous avez des questions sur le copyright de l'IEC ou si vous désirez obtenir des droits supplémentaires sur cette publication, utilisez les coordonnées ci-après ou contactez le Comité national de l'IEC de votre pays de résidence.

IEC Central Office  
3, rue de Varembe  
CH-1211 Geneva 20  
Switzerland

Tel.: +41 22 919 02 11  
[info@iec.ch](mailto:info@iec.ch)  
[www.iec.ch](http://www.iec.ch)

#### About the IEC

The International Electrotechnical Commission (IEC) is the leading global organization that prepares and publishes International Standards for all electrical, electronic and related technologies.

#### About IEC publications

The technical content of IEC publications is kept under constant review by the IEC. Please make sure that you have the latest edition, a corrigenda or an amendment might have been published.

#### IEC Catalogue - [webstore.iec.ch/catalogue](http://webstore.iec.ch/catalogue)

The stand-alone application for consulting the entire bibliographical information on IEC International Standards, Technical Specifications, Technical Reports and other documents. Available for PC, Mac OS, Android Tablets and iPad.

#### IEC publications search - [webstore.iec.ch/advsearchform](http://webstore.iec.ch/advsearchform)

The advanced search enables to find IEC publications by a variety of criteria (reference number, text, technical committee,...). It also gives information on projects, replaced and withdrawn publications.

#### IEC Just Published - [webstore.iec.ch/justpublished](http://webstore.iec.ch/justpublished)

Stay up to date on all new IEC publications. Just Published details all new publications released. Available online and also once a month by email.

#### Electropedia - [www.electropedia.org](http://www.electropedia.org)

The world's leading online dictionary of electronic and electrical terms containing 21 000 terms and definitions in English and French, with equivalent terms in 16 additional languages. Also known as the International Electrotechnical Vocabulary (IEV) online.

#### IEC Glossary - [std.iec.ch/glossary](http://std.iec.ch/glossary)

67 000 electrotechnical terminology entries in English and French extracted from the Terms and Definitions clause of IEC publications issued since 2002. Some entries have been collected from earlier publications of IEC TC 37, 77, 86 and CISPR.

#### IEC Customer Service Centre - [webstore.iec.ch/csc](http://webstore.iec.ch/csc)

If you wish to give us your feedback on this publication or need further assistance, please contact the Customer Service Centre: [sales@iec.ch](mailto:sales@iec.ch).

#### A propos de l'IEC

La Commission Electrotechnique Internationale (IEC) est la première organisation mondiale qui élabore et publie des Normes internationales pour tout ce qui a trait à l'électricité, à l'électronique et aux technologies apparentées.

#### A propos des publications IEC

Le contenu technique des publications IEC est constamment revu. Veuillez vous assurer que vous possédez l'édition la plus récente, un corrigendum ou amendement peut avoir été publié.

#### Catalogue IEC - [webstore.iec.ch/catalogue](http://webstore.iec.ch/catalogue)

Application autonome pour consulter tous les renseignements bibliographiques sur les Normes internationales, Spécifications techniques, Rapports techniques et autres documents de l'IEC. Disponible pour PC, Mac OS, tablettes Android et iPad.

#### Recherche de publications IEC - [webstore.iec.ch/advsearchform](http://webstore.iec.ch/advsearchform)

La recherche avancée permet de trouver des publications IEC en utilisant différents critères (numéro de référence, texte, comité d'études,...). Elle donne aussi des informations sur les projets et les publications remplacées ou retirées.

#### IEC Just Published - [webstore.iec.ch/justpublished](http://webstore.iec.ch/justpublished)

Restez informé sur les nouvelles publications IEC. Just Published détaille les nouvelles publications parues. Disponible en ligne et aussi une fois par mois par email.

#### Electropedia - [www.electropedia.org](http://www.electropedia.org)

Le premier dictionnaire en ligne de termes électroniques et électriques. Il contient 21 000 termes et définitions en anglais et en français, ainsi que les termes équivalents dans 16 langues additionnelles. Egalement appelé Vocabulaire Electrotechnique International (IEV) en ligne.

#### Glossaire IEC - [std.iec.ch/glossary](http://std.iec.ch/glossary)

67 000 entrées terminologiques électrotechniques, en anglais et en français, extraites des articles Termes et Définitions des publications IEC parues depuis 2002. Plus certaines entrées antérieures extraites des publications des CE 37, 77, 86 et CISPR de l'IEC.

#### Service Clients - [webstore.iec.ch/csc](http://webstore.iec.ch/csc)

Si vous désirez nous donner des commentaires sur cette publication ou si vous avez des questions contactez-nous: [sales@iec.ch](mailto:sales@iec.ch).



IEC 60156

Edition 3.0 2018-08

# INTERNATIONAL STANDARD

## NORME INTERNATIONALE

**Insulating liquids – Determination of the breakdown voltage at power frequency – Test method**  
(standards.iteh.ai)

**Isolants liquides – Détermination de la tension de claquage à fréquence industrielle – Méthode d'essai**

INTERNATIONAL  
ELECTROTECHNICAL  
COMMISSION

COMMISSION  
ELECTROTECHNIQUE  
INTERNATIONALE

ICS 29.040

ISBN 978-2-8322-5959-7

**Warning! Make sure that you obtained this publication from an authorized distributor.  
Attention! Veuillez vous assurer que vous avez obtenu cette publication via un distributeur agréé.**

## CONTENTS

FOREWORD.....	4
INTRODUCTION.....	6
1 Scope.....	7
2 Normative references.....	7
3 Terms and definitions .....	7
4 Electrical apparatus.....	7
4.1 General.....	7
4.2 Voltage regulator.....	7
4.3 Step-up transformer .....	8
4.4 Switching system .....	8
4.5 Current-limiting resistors .....	8
4.6 Measuring system .....	8
5 Test assembly .....	8
5.1 General.....	8
5.2 Test cell.....	9
5.3 Electrodes.....	9
5.4 Stirring device.....	10
6 Preparation of electrodes.....	10
7 Test assembly preparation.....	10
8 Sampling.....	11
9 Test procedure.....	11
9.1 Sample preparation.....	11
9.2 Filling of the cell.....	11
10 Application of the voltage.....	11
11 Report.....	12
12 Test data dispersion and reproducibility .....	12
12.1 Test data dispersion.....	12
12.2 Reproducibility .....	13
Annex A (informative) Improved test method .....	14
A.1 Test procedure for improved test method .....	14
A.2 Report .....	15
Annex B (informative) Special test methods for low volume samples .....	16
B.1 Low volume sample test .....	16
Annex C (informative) Representative material for a performance test.....	18
Bibliography .....	19
Figure 1 – Examples of test cells with spherical electrodes 12,5 mm to 13,0 mm diameter.....	9
Figure 2 – Examples of test cells with partially spherical electrodes with 25 mm radius and diameter of 36 mm .....	9
Figure 3 – Graphical representation of coefficient of variation versus mean breakdown voltage .....	13
Figure A.1 – Example of a sequence of breakdown shots for determination of the breakdown voltage.....	15

Figure B.1 – Example of low volume test cell, fixed electrode distance of 2 mm with 2 ml active volume under dielectric stress .....	16
Figure B.2 – Example of low volume test cell, fixed electrode distance of 2,5 mm (150 ml to 200 ml).....	17

**iTeh STANDARD PREVIEW**  
**(standards.iteh.ai)**

[IEC 60156:2018](#)

<https://standards.iteh.ai/catalog/standards/sist/34178fbc-bce5-44d2-ba89-28ab7fd00559/iec-60156-2018>

INTERNATIONAL ELECTROTECHNICAL COMMISSION

**INSULATING LIQUIDS – DETERMINATION OF THE BREAKDOWN VOLTAGE AT POWER FREQUENCY – TEST METHOD**

FOREWORD

- 1) The International Electrotechnical Commission (IEC) is a worldwide organization for standardization comprising all national electrotechnical committees (IEC National Committees). The object of IEC is to promote international co-operation on all questions concerning standardization in the electrical and electronic fields. To this end and in addition to other activities, IEC publishes International Standards, Technical Specifications, Technical Reports, Publicly Available Specifications (PAS) and Guides (hereafter referred to as "IEC Publication(s)"). Their preparation is entrusted to technical committees; any IEC National Committee interested in the subject dealt with may participate in this preparatory work. International, governmental and non-governmental organizations liaising with the IEC also participate in this preparation. IEC collaborates closely with the International Organization for Standardization (ISO) in accordance with conditions determined by agreement between the two organizations.
- 2) The formal decisions or agreements of IEC on technical matters express, as nearly as possible, an international consensus of opinion on the relevant subjects since each technical committee has representation from all interested IEC National Committees.
- 3) IEC Publications have the form of recommendations for international use and are accepted by IEC National Committees in that sense. While all reasonable efforts are made to ensure that the technical content of IEC Publications is accurate, IEC cannot be held responsible for the way in which they are used or for any misinterpretation by any end user.
- 4) In order to promote international uniformity, IEC National Committees undertake to apply IEC Publications transparently to the maximum extent possible in their national and regional publications. Any divergence between any IEC Publication and the corresponding national or regional publication shall be clearly indicated in the latter.
- 5) IEC itself does not provide any attestation of conformity. Independent certification bodies provide conformity assessment services and, in some areas, access to IEC marks of conformity. IEC is not responsible for any services carried out by independent certification bodies.
- 6) All users should ensure that they have the latest edition of this publication.
- 7) No liability shall attach to IEC or its directors, employees, servants or agents including individual experts and members of its technical committees and IEC National Committees for any personal injury, property damage or other damage of any nature whatsoever, whether direct or indirect, or for costs (including legal fees) and expenses arising out of the publication, use of, or reliance upon, this IEC Publication or any other IEC Publications.
- 8) Attention is drawn to the Normative references cited in this publication. Use of the referenced publications is indispensable for the correct application of this publication.
- 9) Attention is drawn to the possibility that some of the elements of this IEC Publication may be the subject of patent rights. IEC shall not be held responsible for identifying any or all such patent rights.

International Standard IEC 60156 has been prepared by IEC technical committee TC 10: Fluids for electrotechnical applications.

This third edition cancels and replaces the second edition published in 1995. This edition constitutes a technical revision and, mainly, confirms the content of the previous edition even if some advances are included. The test method has not been changed for practical reason due to the very large number of instrumentation disseminated around the world, although the use of stirring is now recommended.

The text of this International Standard is based on the following documents:

FDIS	Report on voting
10/1061/FDIS	10/1065/RVD

Full information on the voting for the approval of this International Standard can be found in the report on voting indicated in the above table.

This document has been drafted in accordance with the ISO/IEC Directives, Part 2.

The committee has decided that the contents of this document will remain unchanged until the stability date indicated on the IEC website under "<http://webstore.iec.ch>" in the data related to the specific document. At this date, the document will be

- reconfirmed,
- withdrawn,
- replaced by a revised edition, or
- amended.

## **iTeh STANDARD PREVIEW** **(standards.iteh.ai)**

[IEC 60156:2018](#)

<https://standards.iteh.ai/catalog/standards/sist/34178fbc-bce5-44d2-ba89-28ab7fd00559/iec-60156-2018>

## INTRODUCTION

As normally applied, breakdown voltage of insulating liquids is not a basic material property but an empirical test procedure intended to indicate the presence of contaminants such as water and solid suspended matter and the advisability of carrying out a drying and filtration treatment.

The AC breakdown voltage value of insulating liquids strongly depends on the particular set of conditions used in its measurement. Therefore, standardized testing procedures and equipment are essential for the unambiguous interpretation of test results.

The method described in this document applies to either acceptance tests on new deliveries of insulating liquids, or testing of treated liquids prior to or during filling into electrical equipment, or to the monitoring and maintenance of oil-filled apparatus in service. It specifies rigorous sample-handling procedures and temperature control that should be adhered to when certified results are required. For routine tests, especially in the field, less stringent procedures may be practicable and it is the responsibility of the user to determine their effect on the results.

Annex A (informative) describes, for comparison, an alternative test method which could be introduced in the future. Annex B (informative) describes special test methods, using cells which may include low volume samples. Annex C (informative) describes a reference material for a performance test and check according to IEC 60060-3[1]<sup>1</sup>.

## iTeh STANDARD PREVIEW (standards.iteh.ai)

[IEC 60156:2018](#)

<https://standards.iteh.ai/catalog/standards/sist/34178fbc-bce5-44d2-ba89-28ab7fd00559/iec-60156-2018>

---

<sup>1</sup> Numbers in square brackets refer to the Bibliography.



# INSULATING LIQUIDS – DETERMINATION OF THE BREAKDOWN VOLTAGE AT POWER FREQUENCY – TEST METHOD

## 1 Scope

This document specifies the method for determining the dielectric breakdown voltage of insulating liquids at power frequency. The test procedure is performed in a specified apparatus, where the oil sample is subjected to an increasing AC electrical field until breakdown occurs. The method applies to all types of insulating liquids of nominal viscosity up to 350 mm<sup>2</sup>/s at 40 °C. It is appropriate both for acceptance testing on unused liquids at the time of their delivery and for establishing the condition of samples taken in monitoring and maintenance of equipment.

## 2 Normative references

The following documents are referred to in the text in such a way that some or all of their content constitutes requirements of this document. For dated references, only the edition cited applies. For undated references, the latest edition of the referenced document (including any amendments) applies.

IEC 60475, *Method of sampling insulating liquids*

## 3 Terms and definitions

No terms and definitions are listed in this document.

ISO and IEC maintain terminological databases for use in standardization at the following addresses:

- IEC Electropedia: available at <http://www.electropedia.org/>
- ISO Online browsing platform: available at <http://www.iso.org/obp>

## 4 Electrical apparatus

### 4.1 General

The electrical apparatus consists of the following units:

- 1) voltage regulator,
- 2) step-up transformer,
- 3) switching system,
- 4) current-limiting resistors,
- 5) measuring device.

Two or more of these units may be integrated in any equipment system.

### 4.2 Voltage regulator

The test voltage shall be increased with an automatic control of the required uniform voltage rate of rise. The device should not introduce harmonics disturbances (< 3%) and the AC source should be free from harmonics.

### 4.3 Step-up transformer

The test voltage is obtained by using a step-up or resonant transformer supplied from an AC source using 48 Hz to 62 Hz (sinusoidal waveform). The voltage source value is constantly increased. The controls of the variable low-voltage source shall be capable of varying the test voltage smoothly, uniformly and without overshoots or transients. Incremental increases (produced, for example, by a variable auto-transformer or an amplifier) shall not exceed 2 % of the expected breakdown voltage.

The centre-point of the secondary winding of the transformer should be connected to earth.

### 4.4 Switching system

The circuit shall be opened automatically if a sustained arc between the electrodes occurs and the voltage between the electrodes collapses to a voltage less than 500 V. The primary circuit of the step-up transformer shall be fitted with a circuit-breaker operated by the current sensing device, resulting from the breakdown of the sample and shall break the voltage within 10 ms.

The sensitivity of the current or voltage sensing element depends on the energy-limiting device employed and only approximate guidance can be given.

A cut-off time of < 100  $\mu$ s, as given in the previous edition of this document, is needed to perform multiple breakdowns on silicone liquids.

### 4.5 Current-limiting resistors

To protect the equipment and to avoid excessive decomposition at the instant of breakdown of liquids such as silicone or ester liquids, a resistance limiting the breakdown current shall be inserted in series with the test cell.

The short-circuit current of the transformer and associated circuits shall be within the range of 10 mA to 25 mA for all voltages higher than 15 kV. This may be achieved by a combination of resistors in either or both the primary and secondary circuits of the high-voltage transformer.

### 4.6 Measuring system

For the purposes of this document, the magnitude of the test voltage is defined as its peak value divided by  $\sqrt{2}$ .

The output voltage of the step-up transformer may be measured by means of a measuring system consisting of a voltage divider or a measuring winding of the step-up transformer coupled with a peak-voltmeter. The measuring system shall be calibrated up to the upper scale voltage to be measured. A method of calibration which has been found satisfactory is the use of a transfer standard. This is an auxiliary measuring device which is connected in place of the test cell between the high-voltage terminals to which it presents an impedance similar to the one of the sample liquid. The auxiliary device is separately calibrated against a primary standard [2],[3].

## 5 Test assembly

### 5.1 General

The breakdown voltage test is performed following the method described herewith as a routine test.

## 5.2 Test cell

The volume of the cell shall be between 350 ml and 600 ml.

The cell shall be made from electrically insulating materials, that are not hygroscopic. The cell shall be transparent and chemically inert, resistant to the insulating liquid and to the cleaning agent that shall be used. A glass cell is the preferred option.

The cell shall be provided with a cover and shall be designed to permit easy removal of the electrodes for cleaning and maintenance. To improve homogenization of the test liquid, a rounded bottom shape of the cell is recommended. Containers and covers shall be cleaned by washing with a suitable solvent or clean insulating liquid to remove residues of an earlier sample. After cleaning, containers shall be immediately capped and kept closed until used again. Electrodes shall be stored in clean insulating liquids.

NOTE It is preferable, in the case of esters, to use similar liquid to store the electrodes.

Examples of suitable cell designs are given in Figures 1 and 2.

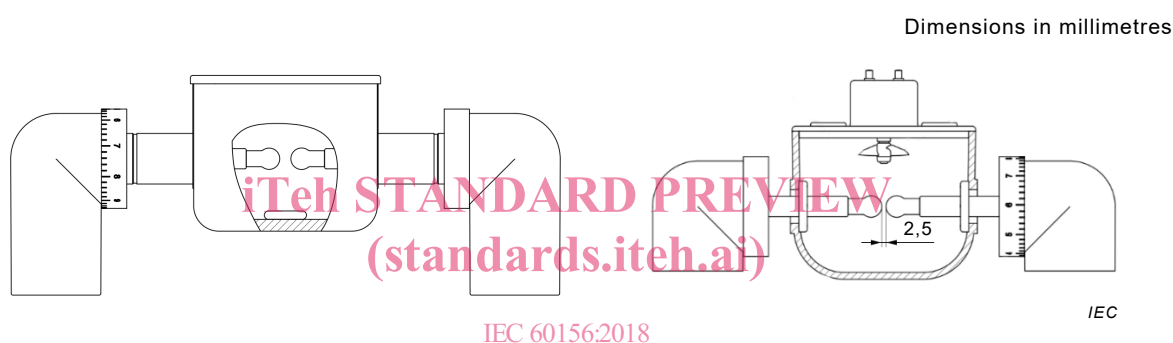

NOTE The stirring device can be mounted on the top (right side figure) or on the bottom (left side figure). The stirring device position and Vernier shifter are reported only as reference.

**Figure 1 – Examples of test cells with spherical electrodes  
12,5 mm to 13,0 mm diameter**

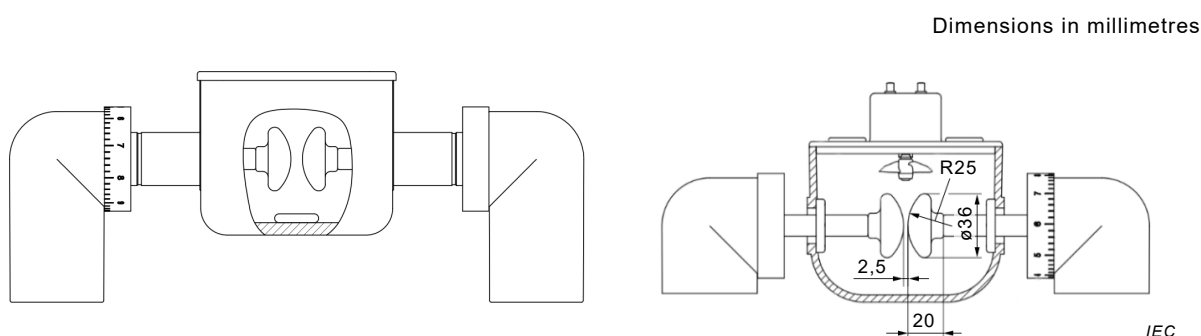

NOTE The stirring device can be mounted on the top (right side figure) or on the bottom (left side figure). The stirring device position and Vernier shifter are reported only as reference.

**Figure 2 – Examples of test cells with partially spherical electrodes  
with 25 mm radius and diameter of 36 mm**

## 5.3 Electrodes

The electrodes shall be made either of brass, bronze or austenitic stainless steel. They shall be polished and, in shape, either spherical (12,5 mm to 13,0 mm diameter) as shown in Figure 1 or in partially spherical shape (25 mm ± 0,25 mm radius) as shown in Figure 2. The axis of the electrode system shall be horizontal and shall be at least 40 mm below the surface

of the test liquid. Any part of the cell or stirrer shall not influence the electric field between the electrodes. The gap between the electrodes shall be  $2,50 \text{ mm} \pm 0,05 \text{ mm}$ .

The electrodes shall be examined frequently for pitting or other damage and shall be maintained or replaced as soon as such damage is observed.

NOTE The electrodes can be replaced or refurbished typically after 5 000 single breakdowns. The surface of the electrodes can be polished with a maximum grain diameter of  $10 \text{ }\mu\text{m}$ . The limit of the arithmetical mean deviation of the roughness profile of the electrodes can be  $R_a \leq 0,5 \text{ }\mu\text{m}$ , according to ISO 4287[4].

#### 5.4 Stirring device

The use of an automatic stirring device is recommended, to be used at all times throughout the test.

The stirrer shall be mounted in the test cell in order to maximize the homogenization of the liquid. It shall be designed so that it is easily cleaned. Stirring shall be achieved by means of a two-bladed or appropriate stirrer of effective diameter 25 mm to 35 mm, axial depth 5 mm to 10 mm, rotating at a speed of 200 r/min to 300 r/min. The stirrer shall not produce air bubbles. It shall be fully immersed in the liquid sample. Examples of stirring systems mounted in test cells are reported in Figures 1 and 2.

NOTE 1 To avoid bubbles between the electrodes the stirrer can rotate preferably in such a direction that bubbles can be removed [5].

NOTE 2 The stirring device can be mounted on the top or on the bottom. In Figures 1 and 2, the stirring device position is reported only as reference.

NOTE 3 A magnetic stirring device can be also used.

### 6 Preparation of electrodes

IEC 60156:2018

[https://standards.iteh.ai/catalog/standards/sist/34178fbc-bce5-44d2-ba89-](https://standards.iteh.ai/catalog/standards/sist/34178fbc-bce5-44d2-ba89-28ab7fd00559/iec-60156-2018)

[28ab7fd00559/iec-60156-2018](https://standards.iteh.ai/catalog/standards/sist/34178fbc-bce5-44d2-ba89-28ab7fd00559/iec-60156-2018)

New electrodes shall be cleaned and fulfil the requirements of 5.3. Preparation of the electrodes shall be according to the following procedure:

- clean all surfaces with a suitable volatile solvent and allow the solvent to evaporate;
- polish with fine abrasive powder (for example, jeweller's rouge) or abrasive paper or cloth, for example crocus cloth (see 5.3);
- after polishing, clean with petroleum spirit (reagent quality: boiling range of about  $40 \text{ }^\circ\text{C}$  to  $80 \text{ }^\circ\text{C}$ ) followed by acetone (reagent quality);
- assemble the electrodes in the cell, fill with a clean, unused insulating liquid of the type to be tested;
- before the first breakdown test, raise the voltage until breakdown 24 times.

This procedure shall be repeated after each cleaning or change of electrodes.

### 7 Test assembly preparation

It is recommended that a separate test cell assembly be reserved for different insulating liquid types.

Test assemblies shall be stored in a dry place, covered and filled with dry insulating liquid of the type in regular use in the cell.

On change of the type of liquid under test, remove all residues of the previous liquid with an appropriate solvent, rinse the assembly with a clean, dry liquid of the same type as the one to be tested, drain and refill.

## 8 Sampling

Sampling shall be carried out in accordance with IEC 60475.

NOTE Breakdown voltage is extremely sensitive to the slightest contamination of the sample by water and particulate matter. Special precautions can be implemented to avoid contamination of the sample and the need for trained personnel and experienced supervision. Unless otherwise required, the sample is taken where the liquid is likely to be most contaminated, usually at the lowest point of the container holding it.

The test is carried out, unless otherwise specified, on the sample as received without drying or degassing.

## 9 Test procedure

### 9.1 Sample preparation

Immediately before filling the test cell, the sample container is gently agitated and turned over several times in such a way as to ensure, as far as possible, a homogeneous distribution of the impurities contained in the liquid without causing the formation of air bubbles.

A possible method is an automatic rotation of the sample container horizontally for 1 min with a recommended speed of 30 r/min.

Equilibrate the sample to room temperature. Unnecessary exposure to the ambient air of the sample shall be avoided.

### 9.2 Filling of the cell

Immediately before commencing the test, drain the test cell and rinse the walls, electrodes and other component parts with the test liquid. Drain and slowly fill with the test liquid avoiding the formation of air bubbles.

Measure and record the temperature of the liquid.

## 10 Application of the voltage

At the time of test, the temperatures shall be maintained at room temperature ( $20\text{ °C} \pm 5\text{ °C}$ ).

Adjust the electrode gap distance to  $2,5\text{ mm} \pm 0,05\text{ mm}$  with a vernier or other system and start the stirrer. The stirrer, if used, shall run continuously throughout the test.

Metallic gauges can damage the surface of the electrodes; hence, they have to be avoided.

The first application of voltage is started approximately 5 min after completion of filling and checking that no air bubbles are visible in the electrode gap. Apply voltage to the electrodes and uniformly increase voltage from zero at the rate of  $2,0\text{ kV/s} \pm 0,2\text{ kV/s}$  until breakdown occurs.

The breakdown voltage is the maximum voltage reached at the time the circuit is opened either automatically (established arc) or manually (visible or audible discharge detected).

Record the value in kilovolts.

Carry out six breakdowns on the same cell filling allowing a pause of at least 2 min after each breakdown before re-application of voltage. Check that no gas bubbles are present within the electrode gap.