**Road vehicles — Special warning lamps —
Dimensions**

Véhicules routiers — Feux spéciaux d'avertissement — Dimensions

iTeh STANDARD PREVIEW
(standards.iteh.ai)

[ISO 4148:1998](https://standards.iteh.ai/catalog/standards/sist/80aacf00-2402-40ec-adfa-033700254088/iso-4148-1998)

<https://standards.iteh.ai/catalog/standards/sist/80aacf00-2402-40ec-adfa-033700254088/iso-4148-1998>



Foreword

ISO (the International Organization for Standardization) is a worldwide federation of national standards bodies (ISO member bodies). The work of preparing International Standards is normally carried out through ISO technical committees. Each member body interested in a subject for which a technical committee has been established has the right to be represented on that committee. International organizations, governmental and non-governmental, in liaison with ISO, also take part in the work. ISO collaborates closely with the International Electrotechnical Commission (IEC) on all matters of electrotechnical standardization.

Draft International Standards adopted by the technical committees are circulated to the member bodies for voting. Publication as an International Standard requires approval by at least 75 % of the member bodies casting a vote.

iTeh STANDARD PREVIEW

International Standard ISO 4148 was prepared by Technical Committee ISO/TC 22, *Road vehicles*, Subcommittee SC 8, *Lighting and signalling*.

This third edition cancels and replaces the second edition (ISO 4148:1988), of which it constitutes a technical revision.

Annex A of this International Standard is for information only.

© ISO 1998

All rights reserved. Unless otherwise specified, no part of this publication may be reproduced or utilized in any form or by any means, electronic or mechanical, including photocopying and microfilm, without permission in writing from the publisher.

International Organization for Standardization
Case postale 56 • CH-1211 Genève 20 • Switzerland
Internet central@iso.ch
X.400 c=ch; a=400net; p=iso; o=isocs; s=central

Printed in Switzerland

Road vehicles — Special warning lamps — Dimensions

1 Scope

This International Standard specifies the dimensions of special warning lamps to ensure interchangeability and accurate positioning, bearing in mind the rapid change of light intensity from such devices in a vertical cross-section of the projected beam.

It applies to special warning lamps mainly intended for use on road vehicles.

NOTE — In certain countries and international bodies, the term “light” is sometimes used instead of “lamp”.

2 Normative reference

The following standard contains provisions which, through reference in this text, constitute provisions of this International Standard. At the time of publication, the edition indicated was valid. All standards are subject to revision, and parties to agreements based on this International Standard are encouraged to investigate the possibility of applying the most recent edition of the standard indicated below. Members of IEC and ISO maintain registers of currently valid International Standards.

ISO 4165:1979, *Road vehicles — Electrical connections — Double-pole connector*.

3 Categories of special warning lamps

This International Standard defines five categories of special warning lamps:

- category A: tube-mounted lamp (see figures 1 to 3);
- category B: flat-base-mounted lamp (see figure 4);
- category C: single-stern-mounted lamps (see figure 5);
- category D: magnetic-base-mounted lamp (see figure 6);
- category E: warning signal unit (see figure 7).

4 Intermediate quick-release devices

An intermediate quick-release device may be used if it accepts warning lamps of categories A, B or C, if it yields the desired accuracy, and if national requirements so permit.

5 Requirements for mounting

5.1 Interchangeability

The warning lamps shall comply with the requirements of figures 1 to 7 as appropriate.

5.2 Mounting accuracy

When mounted correctly, each lamp shall be within 1° of the position specified. In the case of intermediate quick-release devices, the mounting shall be made on a fixture representing the fixing zone for which it is intended. To check mounting accuracy, the lamp shall be mounted five times on an appropriate test fixture, and its attitude determined. In no case shall the inclination vary by more than 1° from the mounting plane for categories B, C and D or from a plane perpendicular to the mounting tube axis for category A.

5.3 Geometric visibility

The apparent surface of a warning lamp shall be visible within the field defined by the following angles of geometric visibility:

- a) horizontal angle: 360°;
- b) vertical angle:
 - 1) for blue lights, 4° above and below the horizontal plane passing through the centre of the light source;
 - 2) for amber lights, 8° above and below the horizontal plane passing through the centre of the light source.

The vertical angle below the horizontal plane can be smaller if the geometric visibility of the lamp is met at points located 1 m above the surface on which the vehicle stands and at 20 m from the vehicle.

In the case where more than one lamp is fitted, the requirements are met if at least one lamp is visible under the conditions specified.

6 Identification

Identification shall include the following:

- a) the manufacturer's name, the model number and the category of device;
- b) the colour and any special conditions (for example insulated return, ADR, etc.).

Dimensions in millimetres

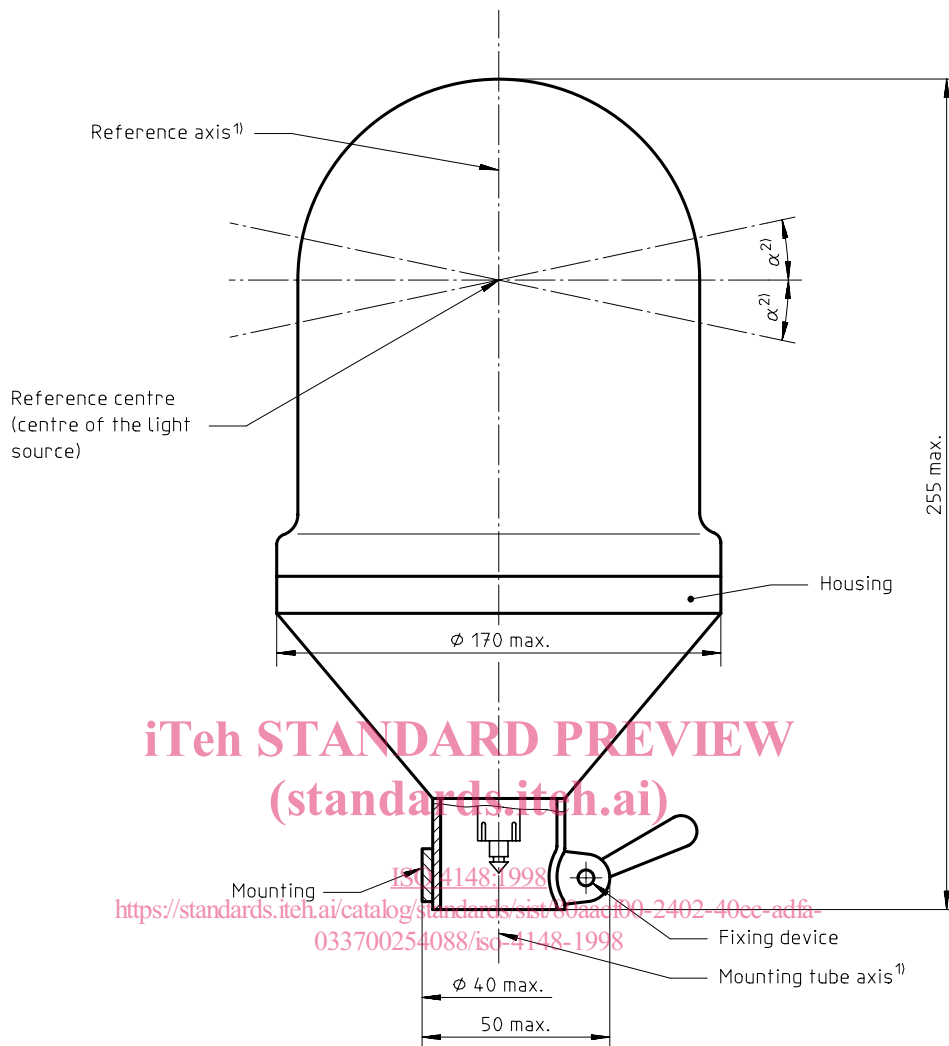

1) The reference axis is an axis perpendicular to the surface on which the unladen vehicle stands. The mounting tube axis shall be parallel to the reference axis.

2) Angle within which light intensities are specified. For blue special warning lamps, this angle is 4°; for amber special warning lamps, it is 8°.

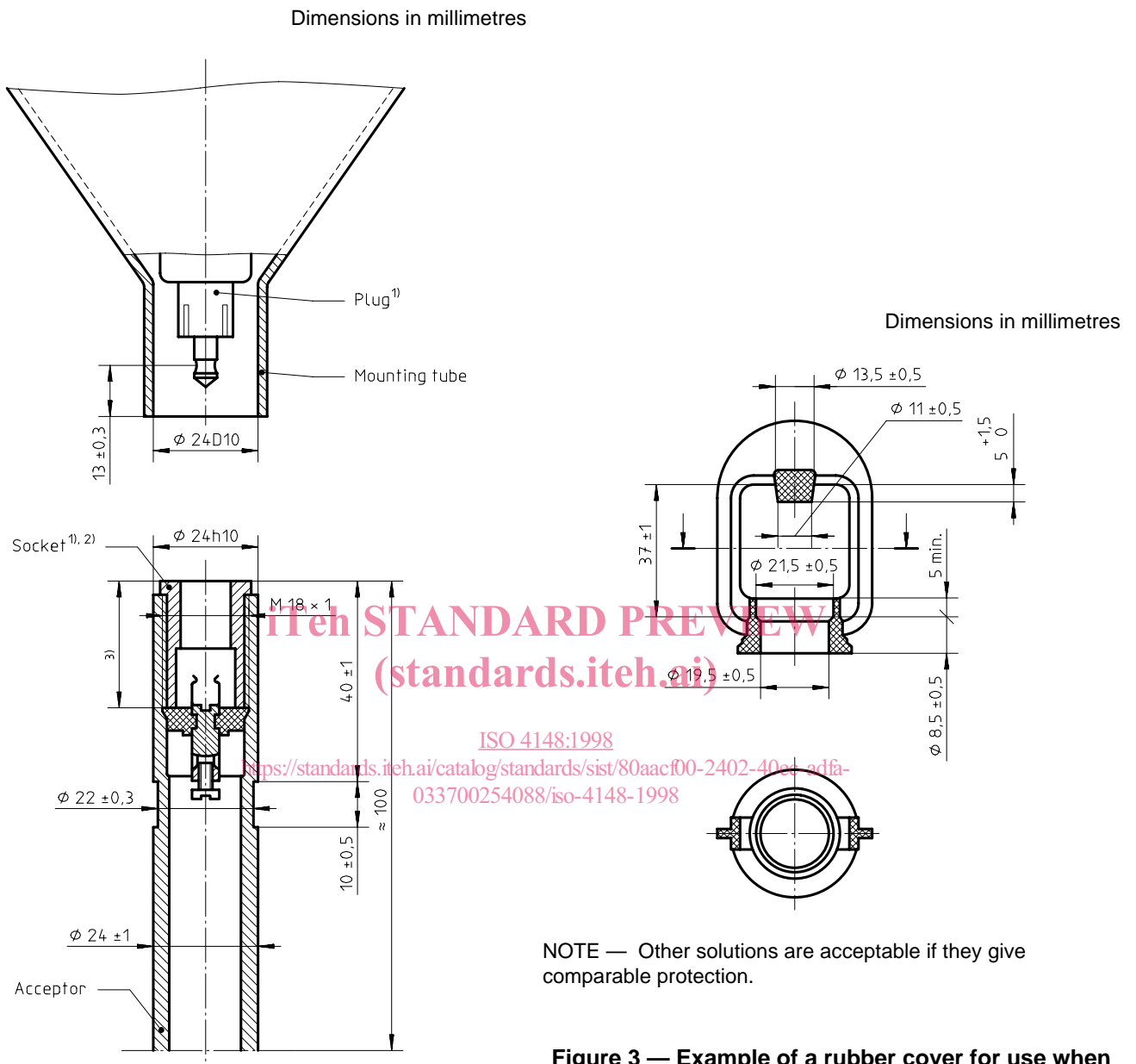
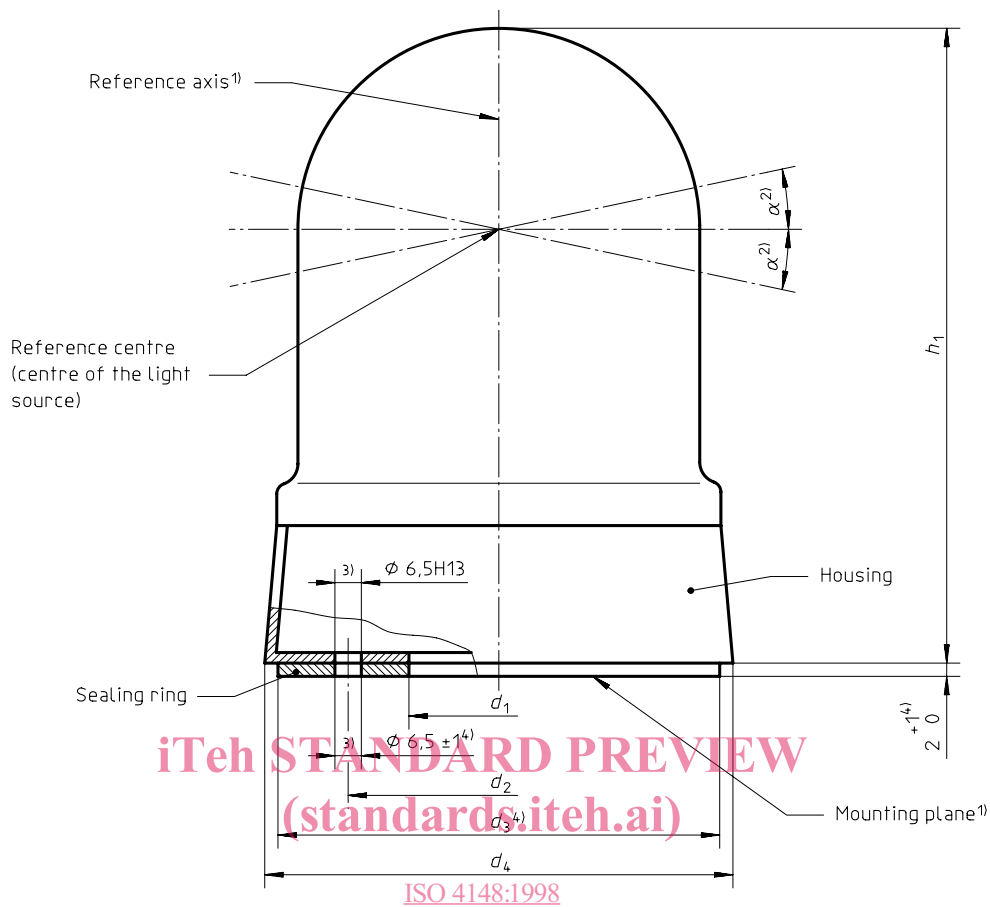

Figure 3 — Example of a rubber cover for use when the special warning lamp (category A) is not mounted

- 1) Plug and socket dimensions shall meet the requirements of ISO 4165.
- 2) A rubber cover shall be used when the special warning lamp is not mounted (see figure 3).
- 3) Internal thread reach: 18 min.

Figure 2 — Tube-mounted special warning lamp (category A) mounting tube and acceptor dimensions

Dimensions in millimetres



<https://standards.iteh.ai/catalog/standards/sist/80aac100-2402-40ec-adfa->

- 1) The reference axis is an axis perpendicular to the surface on which the unladen vehicle stands. The mounting plane of the lamp shall be perpendicular to the reference axis.
- 2) Angle within which light intensities are specified. For blue special warning lamps, this angle is 4°; for amber special warning lamps, it is 8°.
- 3) Three holes, 120° apart.
- 4) The hole diameter $6,5 \pm 1$, dimension d and the thickness 2^{+1}_0 apply only to separate sealing rings; they are not relevant to sealing integral with the body.

Size	d_1 min.	$d_2^*)$	d_3 min.	d_4 max.	h_1 max.
1	108	130	145	190	235
2	170	200	220	240	255

*) Tolerances:
 — for the housing $\pm 0,5$;
 — for a separate sealing ring ± 1 .

Figure 4 — Flat-base-mounted special warning lamp (category B)

Dimensions in millimetres

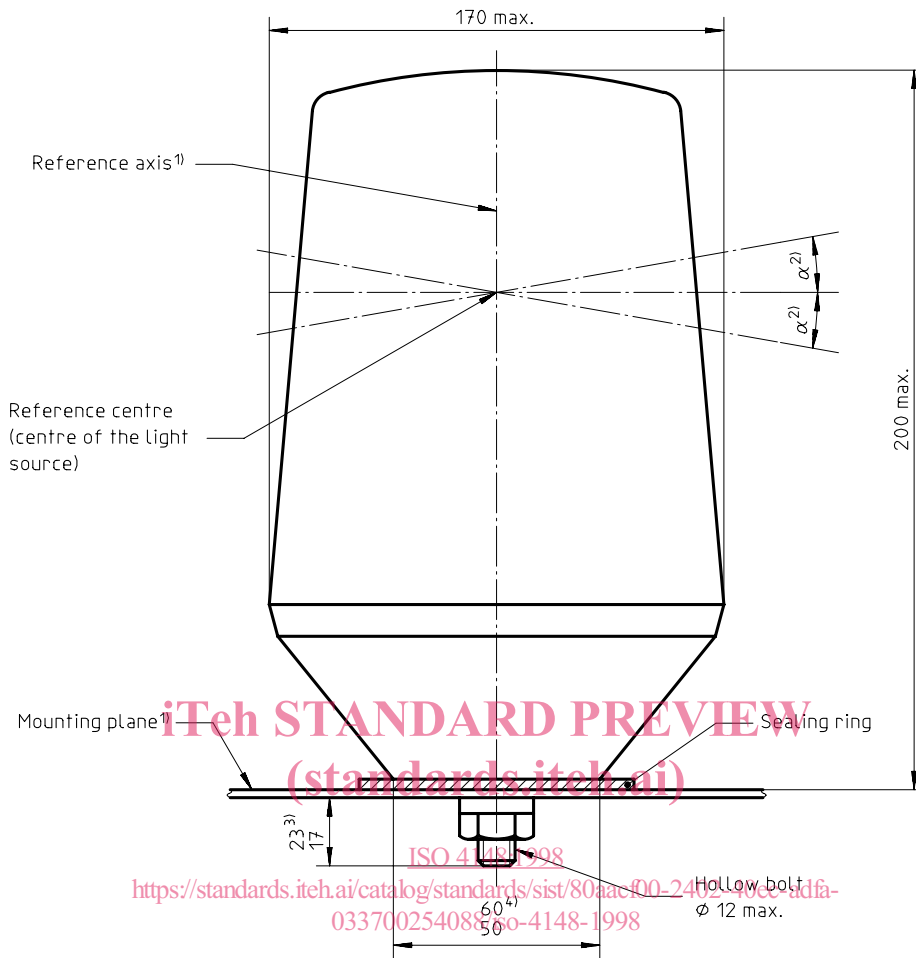

- 1) The reference axis is an axis perpendicular to the surface on which the unladen vehicle stands. The mounting plane of the lamp shall be perpendicular to the reference axis.
- 2) Angle within which light intensities are specified. For blue special warning lamps, this angle is 4°; for amber special warning lamps, it is 8°.
- 3) Dimension applies with the device on a 1 mm thick flat plate.
- 4) The maximum value of this dimension, the diameter of the seating surface, will be the outer diameter of the sealing ring or the flat base of the device, whichever is the smaller.

Dimensions in millimetres

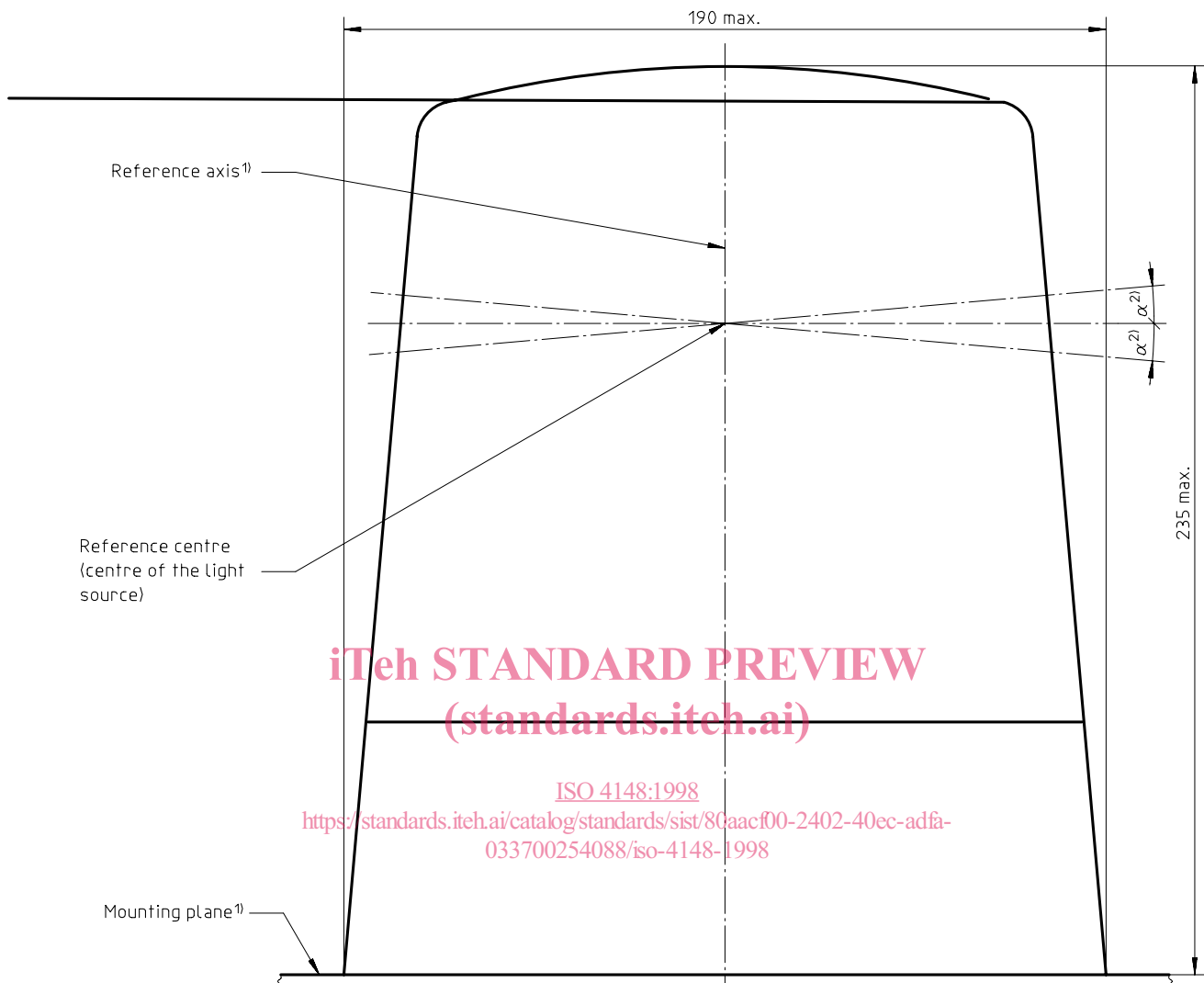

1) The reference axis is an axis perpendicular to the surface on which the unladen vehicle stands. The mounting plane of the lamp shall be perpendicular to the reference axis.

2) Angle within which light intensities are specified. For blue special warning lamps, this angle is 4°; for amber special warning lamps, it is 8°.

Figure 6 — Magnetic-base-mounted special warning lamp (category D)