



Designation: D 4971 – 02

Standard Test Method for Determining the In Situ Modulus of Deformation of Rock Using the Diametrically Loaded 76-mm (3-in.) Borehole Jack¹

This standard is issued under the fixed designation D 4971; the number immediately following the designation indicates the year of original adoption or, in the case of revision, the year of last revision. A number in parentheses indicates the year of last approval. A superscript epsilon (ϵ) indicates an editorial change since the last revision or reapproval.

1. Scope *

1.1 This test method covers the estimation of in situ modulus of a rock mass at various depths and orientations. Information on time-dependent deformation may also be obtained.

1.2 All observed and calculated values shall conform to the guidelines for significant digits and rounding established in Practice D 6026.

1.2.1 The method used to specify how data are collected, calculated, or recorded in this standard is not directly related to the accuracy to which the data can be applied in design or other uses, or both. How one applies the results obtained using this standard is beyond its scope.

1.3 The values stated in SI units are regarded as standard. The inch-pound units in parentheses are for information only.

1.4 *This standard does not purport to address all of the safety concerns, if any, associated with its use. It is the responsibility of the user of this standard to establish appropriate safety and health practices and determine the applicability of regulatory limitations prior to use.*

2. Referenced Documents

2.1 ASTM Standards:

D 653 Terminology Relating to Soil, Rock and Contained Fluids²

D 3740 Practice for Minimum Requirements for Agencies Engaged in the Testing and/or Inspection of Soil and Rock Used in Engineering Design and Construction²

D 6026 Practice for Using Significant Digits in Geotechnical Data³

D 6032 Test Method for Determining Rock Quality Designation [RQD] of Rock Core³

¹ This test method is under the jurisdiction of ASTM Committee D18 on Soil and Rock and is the direct responsibility of Subcommittee D18.12 on Rock Mechanics. Current edition approved Nov. 10, 2002. Published January 2003.. Originally approved in 1989. Last previous edition approved in 1998 as D 4971–89(1998).

² Annual Book of ASTM Standards, Vol 04.08.

³ Annual Book of ASTM Standards, Vol 04.09.

3. Terminology

3.1 See Terminology D653 for general definitions.

3.2 *Definitions of Terms Specific to This Standard:*

3.2.1 *deformation*—change in shape or size, (see Terminology D 653). In this test method deformation is the change in the diameter of the borehole.

3.2.2 *modulus of deformation*—ratio of stress to strain for a material under given loading conditions; numerically equal to the slope of the tangent or the secant of the stress-strain curve. The use of the term modulus of elasticity is recommended for materials that deform in accordance with Hooke's law, and the term modulus of deformation is recommended for materials that deform otherwise, (see Terminology D 653). In this test method, the modulus of deformation is calculated from the applied fluid pressure, the relative change in hole diameter, a function of Poisson's ratio, and a constant.

3.2.3 *jack efficiency*—ratio of the jack plate pressure to the applied hydraulic pressure.

4. Summary of Test Method

4.1 The 76 mm (3.0 in.) jacks, (see Fig. 1 and Fig. 2), induce unidirectional pressure to the walls of a borehole by means of two opposed curved steel platens each covering a 90° sector, over a length of 20.3 cm (8 in.).

4.2 Raw data from a test consist of hydraulic-line pressure, Q_h , versus readout from linear variable differential transformers (LVDT's) measuring platen movement. Knowing the displacement calibration of the LVDT's, the raw data can be transformed to a test record of hydraulic pressure versus hole diameter, D . For each increment of pressure, ΔQ_h , and hole deformation, ΔD , theoretical data analysis (1),⁴ assuming rigid jack plates and full 90° contact, give the theoretical rock mass modulus, E ($E_{\text{theoretical}}$) as a function $E = f(\Delta Q_h \cdot \Delta D \cdot T^*)$, where T^* is a coefficient dependent upon Poisson's ratio. If E is measured on a linear segment of the loading curve, common

⁴ The boldface numbers in parentheses refer to a list of references at the end of the standard.

*A Summary of Changes section appears at the end of this standard.

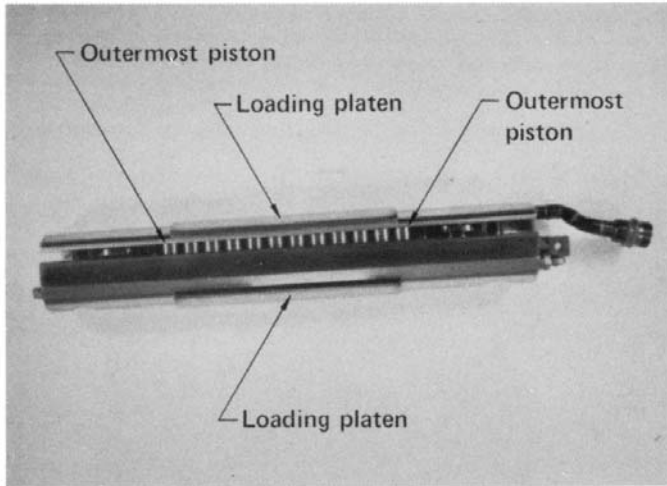

a) Assembled

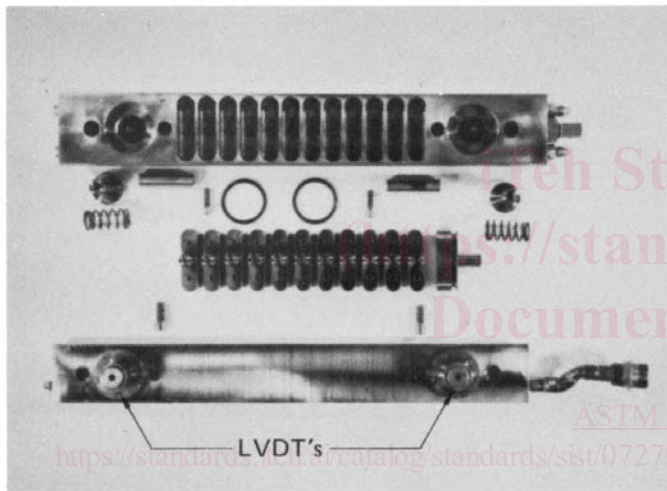

b) Disassembled

FIG. 1 The 76-mm (3-in.) Borehole Jack

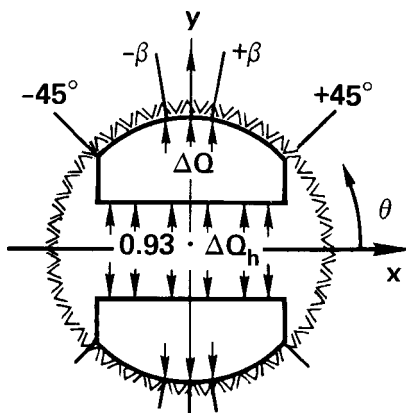

FIG. 2 Schematic of Loading of the Borehole Jack

terminology is modulus of deformation. If E is measured on an unloading linear segment, it is referred to as the recovery modulus.

5. Significance and Use

5.1 Results of this test method are used to predict displacements in rock mass caused by loads from a structure or from underground construction. It is one of several tests that should be performed.

5.2 Because the jack can apply directed loads, this test method can be performed to provide an estimate of anisotropy.

5.3 In theory, the analysis of test data is straight forward; the modulus estimate requires a record of applied hydraulic pressure versus borehole diameter change, and a knowledge of the rock's Poisson's ratio. In practice, the above procedure, using the original theoretical formula, frequently has resulted in computing a material modulus that was demonstrably too low.

5.4 For analyzing the test data it is assumed that the rock mass is linearly elastic, isotropic, and homogeneous. Within these assumptions, this test method can provide useful data for rock masses for which equivalent continuous properties can not be found or estimated.

NOTE 1—Notwithstanding the statements on precision and bias contained in this test method; the precision of this test method is dependent on the competence of the personnel performing it, and the suitability of the equipment and facilities used. Agencies that meet the criteria of Practice D 3740 are generally considered capable of competent and objective testing. Users of this test method are cautioned that compliance with Practice D 3740 does not in itself assure reliable testing. Reliable testing depends on many factors; Practice D 3740 provides a means of evaluating some of those factors.

6. Interferences

6.1 It is assumed that the tensile and compressive moduli of the rock are equal and there is no tensile cracking induced in the rock mass because of jack loading. If tensile cracks are created at 90° to the loading direction, it has been shown (1) that the calculated modulus values can decrease by up to 29%. Therefore, tensile cracking would result in a decrease in the slope of the loading curve and test data in the region of decreased slope should not be used.

6.2 The volume of rock mass involved in the 76 mm (3.0 in.) diameter jack test has been estimated (2) to be about $0.15 \text{ m}^3 (5 \text{ ft}^3)$. This volume may not include enough discontinuities to be representative of the rock mass on a larger scale.

6.3 Two aspects of jack behavior, discussed in 6.3.1 and 6.3.2, require careful consideration in the analysis of test data and can be compensated for by the procedure outlined in this test method and detailed by Heuze and Amadei (3).

6.3.1 The platen/rock contact may not cover 90° of the borehole circumference, as assumed, because of radius mismatch between the jack and the hole (4, 5).

6.3.2 In rock with modulus of deformation greater than about 7 GPa (10^6 psi), there is a longitudinal concave outward bending of the jack platens that requires correction. This correction is necessary because the bending gives higher displacements at the ends than at the center of the loading platens and LVDT displacement gages are located near the ends of the platens.

7. Apparatus

7.1 *Borehole Jack*—The borehole jack for which equations and corrections are presented in Section 12 is the so-called “hard rock” jack, that is currently manufactured under patent. The manufacturer’s specifications are: range of travel is 13 mm (0.5 in.) from closed at 70 mm (2.75 in.) to fully open at 83 mm (3.25 in.), maximum pressure on borehole wall is 64 MPa (9300 psi), and deformation resolution is 0.025 mm (0.001 in.). The maximum jack pressure is achieved with a hydraulic system pressure of 69 MPa (10 000 psi). Deformation is measured by an LVDT at each end of the loading platens. These are referred to as the near and far LVDT respectively.

7.2 *Pressure Gage*—A hydraulic gage or electronic transducer may be used to measure the hydraulic system pressure. The gage shall have an accuracy of at least 280 kPa (40 psi), including errors introduced by the readout equipment, and a resolution of at least 140 kPa (20 psi).

7.3 *Casing Alignment System*—The borehole jack is attached to 73 mm (2.875 in.) BX drill casing and placed into position in the borehole. To determine the orientation of the jack, an orientation mark is transferred to successive sections of casing as they are added. To avoid introducing a systematic and progressive error into orientation, an alignment device shall be used to transfer the mark from one casing section to another. In vertical boreholes, a plumb line may be sufficient. In inclined or horizontal boreholes, a marking guide such as the one shown on Fig. 3 has been found satisfactory (6).

8. Sampling, Test Specimens, and Test Units

8.1 *Number and Orientation of Boreholes*—The number, spacing, and orientation of boreholes depend on the geometry of the project and the geology of the site.

8.2 Rock Sampling:

8.2.1 Each type of rock should be tested. In addition, areas of low modulus of deformation, such as fracture or alteration zones within a rock mass, are of particular interest and should be tested.

8.2.2 Tests should be conducted at different orientations to sample the anisotropy of the rock mass, for example, parallel and perpendicular to the long axes of the columns in a basalt flow. Boreholes should generally be orthogonal to each other and either parallel or perpendicular to the structure of the rock formation. At least ten tests in each rock material are recommended.

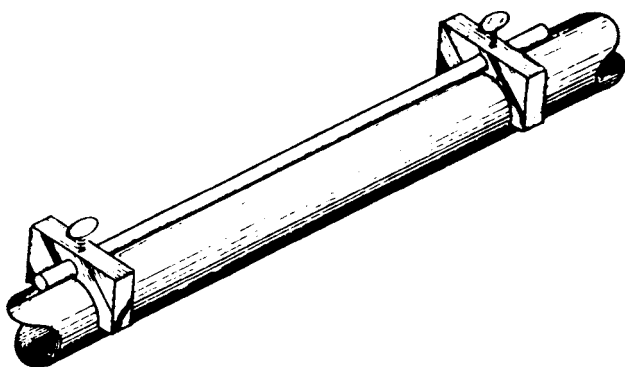

FIG. 3 Marking Guide on Section of Casing

8.3 *Boreholes Reamed*—It is recommended that a reaming shell with a nominal outside diameter of 76 mm (3 in.) be used. It is further recommended that a bit fabricated to reaming shell gage 76 mm (3 in.) also be used. This will minimize the radius mismatch between the borehole and the jack. Accurate measurement of the diameter of the borehole is important.

8.4 *Boreholes Cored*—The boreholes shall be drilled using diamond core techniques; continuous core should be obtained. Oriented cores are desirable but not mandatory.

8.5 *Core Logged*—The recovered core should be completely logged, with emphasis on fractures and other mechanical inhomogeneties and water pressure. Rock quality designation (RQD) should be calculated for each 1.5 m (5 ft) of hole cored or core run, in accordance with Test Method D 6032.

8.6 *Test Location*—Within each borehole, locations for each test should be selected based on the core logs. In some cases observation of the borehole with a borescope or borehole camera (film or television) may be useful.

9. Personnel and Equipment Requirements

9.1 *Personnel*—All personnel involved in performing the test, including technicians and test supervisors, should be under the guidance of someone thoroughly familiar with the use of the jack. Sometimes the personnel may be required to be formally pre-qualified under a quality assurance (QA) procedures established as part of the overall testing program.

9.2 *Equipment Performance Verification*—The compliance of all equipment and apparatus with performance specifications of this procedure shall be verified. Performance verification is generally done by calibrating the equipment and measurement systems according to established procedures.

10. Calibration

10.1 The borehole jack shall be calibrated before and at the completion of the program according to manufacturer’s or equivalent directions (7). In addition, the jack shall be calibrated during the test program if the program consists of many tests or if the deformation readings become suspect. This is particularly likely if the difference in the readings of near and far LVDT’s exceeds the manufacturer’s recommendation of 0.5 mm (0.02 in.), indicating excessive misalignment of the platens.

10.2 Calibration of the boreholes jack must be documented. Personnel calibrating the equipment must be qualified in advance.

11. Procedure

11.1 Test each distinctive rock material in a borehole.

11.2 *Testing Discontinuities*—Locate tests in both intact zones and fractured zones to evaluate the effects of discontinuities. If the two LVDT’s give significantly different displacement (≥ 0.5 mm or 0.02 in.), discard the data and relocate the jack.

11.3 *Boreholes*—Boreholes shall be free from dirt and drill cuttings. Wash the borehole with clean water if necessary.

11.4 *Initial Seating Pressure*—When the jack is at the test location and in the desired orientation, raise the hydraulic pressure to 350 kPa (50 psi) to seat the platens against the