



# SLOVENSKI STANDARD

## SIST EN 716-2:2008

01-september-2008

Nadomešča:

SIST EN 716-2:1996

---

**Pohištvo - Otroške postelje in zložljive posteljice za domačo uporabo - 2. del:  
Preskusne metode**

Furniture - Children's cots and folding cots for domestic use - Part 2: Test methods

Möbel - Kinderbetten und Reisekinderbetten für den Wohnbereich - Teil 2: Prüfverfahren

Meubles - Lits a nacelle fixes et pliants a usage domestique pour enfants - Partie 2 :  
Méthodes d'essai

[SIST EN 716-2:2008](https://standards.iteh.ai/catalog/standards/sist/779664d3-b149-49ac-bef1-7300/sist-en-716-2-2008)

[https://standards.iteh.ai/catalog/standards/sist/779664d3-b149-49ac-bef1-](https://standards.iteh.ai/catalog/standards/sist/779664d3-b149-49ac-bef1-7300/sist-en-716-2-2008)

**Ta slovenski standard je istoveten z: EN 716-2:2008**

---

**ICS:**

97.140

Pohištvo

Furniture

**SIST EN 716-2:2008**

**en,fr,de**

**iTeh STANDARD PREVIEW**  
**(standards.iteh.ai)**

SIST EN 716-2:2008

<https://standards.iteh.ai/catalog/standards/sist/779664d3-b149-49ac-bef1-fe1ddf4c7300/sist-en-716-2-2008>

EUROPEAN STANDARD  
NORME EUROPÉENNE  
EUROPÄISCHE NORM

**EN 716-2**

March 2008

ICS 97.140; 97.190

Supersedes EN 716-2:1995

English Version

**Furniture - Children's cots and folding cots for domestic use -  
Part 2: Test methods**

Meubles - Lits à nacelle fixes et pliants à usage domestique  
pour enfants - Partie 2 : Méthodes d'essai

Möbel - Kinderbetten und Reisekinderbetten für den  
Wohnbereich - Teil 2: Prüfverfahren

This European Standard was approved by CEN on 2 February 2008.

CEN members are bound to comply with the CEN/CENELEC Internal Regulations which stipulate the conditions for giving this European Standard the status of a national standard without any alteration. Up-to-date lists and bibliographical references concerning such national standards may be obtained on application to the CEN Management Centre or to any CEN member.

This European Standard exists in three official versions (English, French, German). A version in any other language made by translation under the responsibility of a CEN member into its own language and notified to the CEN Management Centre has the same status as the official versions.

CEN members are the national standards bodies of Austria, Belgium, Bulgaria, Cyprus, Czech Republic, Denmark, Estonia, Finland, France, Germany, Greece, Hungary, Iceland, Ireland, Italy, Latvia, Lithuania, Luxembourg, Malta, Netherlands, Norway, Poland, Portugal, Romania, Slovakia, Slovenia, Spain, Sweden, Switzerland and United Kingdom.

[SIST EN 716-2:2008](https://standards.iteh.ai/catalog/standards/sist/779664d3-b149-49ac-bef1-fe1dd4c7300/sist-en-716-2-2008)

<https://standards.iteh.ai/catalog/standards/sist/779664d3-b149-49ac-bef1-fe1dd4c7300/sist-en-716-2-2008>



EUROPEAN COMMITTEE FOR STANDARDIZATION  
COMITÉ EUROPÉEN DE NORMALISATION  
EUROPÄISCHES KOMITEE FÜR NORMUNG

Management Centre: rue de Stassart, 36 B-1050 Brussels

## Contents

Page

|  |           |
|--|-----------|
| Foreword.....  | 4         |
| <b>1</b> <b>Scope .....</b>  | <b>5</b>  |
| <b>2</b> <b>Normative references .....</b>   | <b>5</b>  |
| <b>3</b> <b>General test conditions .....</b>  | <b>5</b>  |
| 3.1    Preliminary preparation .....   | 5         |
| 3.2    Test equipment .....  | 5         |
| 3.3    Application of forces .....   | 6         |
| 3.4    Tolerances .....  | 6         |
| 3.5    Test sequence .....   | 6         |
| 3.6    Prevention of movement during test .....  | 6         |
| <b>4</b> <b>Test apparatus .....</b>   | <b>6</b>  |
| 4.1    Measuring probes .....  | 6         |
| 4.2    Bottom impactor .....   | 7         |
| 4.3    Test mattress.....  | 8         |
| 4.4    Side impactor .....   | 8         |
| 4.5    Loading pad.....  | 9         |
| 4.6    Stops .....   | 9         |
| 4.7    Floor surface .....   | 10        |
| 4.8    Test chain and mass .....   | 10        |
| 4.9    Small parts cylinder.....   | 10        |
| 4.10    Test mass .....  | 11        |
| 4.11    Bite tester .....  | 11        |
| 4.12    Retaining block .....  | 12        |
| 4.13    Foothold template.....   | 13        |
| 4.14    Head probes .....  | 13        |
| 4.14.1    Small head probe.....  | 13        |
| 4.14.2    Large head probe.....  | 14        |
| 4.15    Template for V-shaped openings .....   | 14        |
| 4.16    Test dummy.....  | 15        |
| <b>5</b> <b>Test procedures .....</b>  | <b>15</b> |
| 5.1    Assembly and inspection .....   | 15        |
| 5.2    Footholds.....  | 16        |
| 5.2.1    Determination of a foothold.....  | 16        |
| 5.2.2    Tests for footholds .....   | 17        |
| 5.2.3    Measurement of distance between footholds and/or top of cot sides and ends..... | 19        |
| 5.2.4    Flexible materials.....   | 20        |
| 5.3    Measurements.....   | 20        |
| 5.3.1    Holes, gaps and openings inside the cot.....                                    | 20        |
| 5.3.2    Holes, gaps and openings on the outside of the cot .....                        | 21        |
| 5.4    Small parts.....  | 23        |
| 5.4.1    General.....  | 23        |
| 5.4.2    Torque test .....   | 23        |
| 5.4.3    Tension test.....   | 24        |
| 5.5    Bite test.....  | 24        |
| 5.6    Strength of cot base and mattress base (impact test).....                         | 24        |
| 5.7    Strength of sides and ends.....   | 25        |
| 5.7.1    Static load test of side slats (bending test) .....                             | 25        |
| 5.7.2    Strength of sides or side slats (impact test).....                              | 26        |
| 5.7.3    Strength of corners (impact test).....  | 27        |

|        |   |    |
|--------|---|----|
| 5.7.4  | Strength of mesh and flexible sides and ends (static load test) ..... | 27 |
| 5.8    | Strength of frame and fastenings .....                                | 28 |
| 5.8.1  | Vertical static load test .....                                       | 28 |
| 5.8.2  | Durability test.....  | 29 |
| 5.9    | Snag points .....   | 30 |
| 5.10   | Stability.....  | 30 |
| 5.11   | Locking mechanisms .....  | 31 |
| 5.11.1 | Durability .....  | 31 |
| 5.11.2 | Strength.....   | 31 |
| 6      | Test report.....  | 31 |
|        | Bibliography.....   | 32 |

**iTeh STANDARD PREVIEW**  
**(standards.iteh.ai)**

[SIST EN 716-2:2008](https://standards.iteh.ai/catalog/standards/sist/779664d3-b149-49ac-bef1-fe1ddf4c7300/sist-en-716-2-2008)

<https://standards.iteh.ai/catalog/standards/sist/779664d3-b149-49ac-bef1-fe1ddf4c7300/sist-en-716-2-2008>

**EN 716-2:2008 (E)****Foreword**

This document (EN 716-2:2008) has been prepared by Technical Committee CEN/TC 207 "Furniture", the secretariat of which is held by UNI.

This European Standard shall be given the status of a national standard, either by publication of an identical text or by endorsement, at the latest by September 2008, and conflicting national standards shall be withdrawn at the latest by September 2008.

Attention is drawn to the possibility that some of the elements of this document may be the subject of patent rights. CEN [and/or CENELEC] shall not be held responsible for identifying any or all such patent rights.

This document supersedes EN 716-2:1995.

According to the CEN/CENELEC Internal Regulations, the national standards organizations of the following countries are bound to implement this European Standard: Austria, Belgium, Bulgaria, Cyprus, Czech Republic, Denmark, Estonia, Finland, France, Germany, Greece, Hungary, Iceland, Ireland, Italy, Latvia, Lithuania, Luxembourg, Malta, Netherlands, Norway, Poland, Portugal, Romania, Slovakia, Slovenia, Spain, Sweden, Switzerland and the United Kingdom.

Significant technical differences between this edition and EN 716-2:1995 are as follows:

- ITCH STANDARD PREVIEW  
(standards.itech.ai)  
SIST EN 716-2:2008  
<https://standards.itech.ai/catalog/standards/sist/779664d3-b149-49ac-bef1-614d6e73001a/en-716-2-2008>
- a) Following items were made more concrete or introduced: Test equipment (3.2), Application of forces (3.3), Tolerances (3.4) and under Test equipment (4), Test mattress (4.3), Device for bite test (4.11), Template for foot hold (4.13), Head probes (4.14), Testing device for V-shaped openings (4.15) and Retaining block (4.12);
  - b) Elaboration and specification of the test procedures (5), Assembly and inspection (5.1), for the measurements of closed openings testing with at test probe (5.3.2.1) and measurement of V-shaped openings testing with a test probe (5.3.2.2) were introduced, Small parts (5.4), Bite test (5.5), Strength of sides and ends (5.7), Snag points (5.9) and Locking mechanisms (5.11);
  - c) Testing of brakes of the rollers and test chain with disc were deleted;
  - d) Revised editorially and with regard to content.

## 1 Scope

This part of EN 716 specifies test methods for assessing the safety of children's cots and folding cots for domestic use.

It applies to children's cots and folding cots with an internal length greater than 900 mm but not more than 1 400 mm.

## 2 Normative references

The following referenced documents are indispensable for the application of this document. For dated references, only the edition cited applies. For undated references, the latest edition of the referenced document (including any amendments) applies.

EN ISO 2439:2000, *Flexible cellular polymeric materials - Determination of hardness (indentation technique) (ISO 2439:1997, including Technical Corrigendum 1:1998)*

ISO 7619-2, *Rubber, vulcanized or thermoplastic — Determination of indentation hardness — Part 2: IRHD pocket meter method*

## 3 General test conditions

### 3.1 Preliminary preparation

The tests are designed to be applied to a cot that is fully assembled and ready for use.

The test unit shall be stored in indoor ambient conditions for at least one week immediately prior to testing. Any deviation from this procedure shall be stated in the test report.

Before testing, any fabrics intended to be removable shall be cleaned or washed twice in accordance with the manufacturer's instructions. If no instructions are supplied, the manner of washing/cleaning shall be stated in the test report.

The tests shall be carried out under indoor ambient conditions, but if during a test the atmospheric temperature is outside the range 15 °C to 25 °C, the maximum and/or minimum temperature shall be recorded in the test report.

The cot shall be tested as delivered. If the cot is a knock down type, it shall be assembled according to the manufacturer's instructions supplied with the cot. If the cot can be assembled, combined or adjusted in different ways, the most adverse combination shall be used for each test.

Knock-down fittings shall be tightened before testing. Further re-tightening shall not take place unless this is specifically required by the manufacturer.

In the case of designs not catered for in the test procedures, the tests shall be carried out as far as possible as described, and a list made of the deviations from the test procedures.

### 3.2 Test equipment

Unless otherwise specified, the tests may be applied by any suitable device because results are dependent only upon correctly applied forces and loads and not upon the apparatus.

**EN 716-2:2008 (E)**

The equipment shall not inhibit the deformation of the cot during testing. It shall be able to move so that it can follow the deformation of the cot during testing, so that the loads are always applied at the specified point and in the specified direction.

All loading pads shall be capable of pivoting in relation to the direction of the applied force. The pivot point shall be as close as practically possible to the load surface.

**3.3 Application of forces**

The forces in the static load tests shall be applied sufficiently slowly enough to ensure that negligible dynamic force is applied.

The forces in durability tests shall be applied at a rate to ensure that excessive heating does not occur.

**3.4 Tolerances**

Unless otherwise stated, the following tolerances apply:

- Forces:  $\pm 5\%$  of the nominal force;
- Masses:  $\pm 0,5\%$  of the nominal mass;
- Dimensions:  $\pm 1,0$  mm of the nominal dimension;
- Angles:  $\pm 2^\circ$  of the nominal angle;
- Positioning of loading pads:  $\pm 5$  mm;
- Duration of forces:  $(2 \pm 1)$  s for durability tests  
( $10 \pm 2$ ) s for static load tests, including tension, torque and bite tests.

The tests are described in terms of the application of forces. Masses can, however, be used. The relationship  $10\text{ N} = 1\text{ kg}$  shall be used for this purpose.

**3.5 Test sequence**

The tests shall be carried out in the order laid down in this standard and on the same cot.

**3.6 Prevention of movement during test**

If the cot tends to slide or roll during the tests specified in clause 5, it shall be restrained by stops (4.6).

**4 Test apparatus****4.1 Measuring probes**

Probes made of plastics or other hard, smooth material mounted on a force-measuring device.

There shall be one probe with a diameter of 7 mm ( $-0,1/+0$  mm), see Figure 1a.

There shall be five probes with an angle of  $30^\circ \pm 0,5^\circ$  with diameters of 25 mm ( $0/+0,1$  mm), 45 mm ( $0/+0,1$  mm), 60 mm ( $0/+0,1$  mm), 65 mm ( $0/+0,1$  mm) and 85 mm ( $0/+0,1$  mm) with conical ends, see Figure 1b.



There shall be four cylindrical probes with diameters of 5 mm (-0,1/+0 mm), 7 mm (-0,1/+0 mm), 12 mm (0/+0,1 mm) and 18 mm (0/+0,1 mm) with hemispherical ends, see Figure 1c.

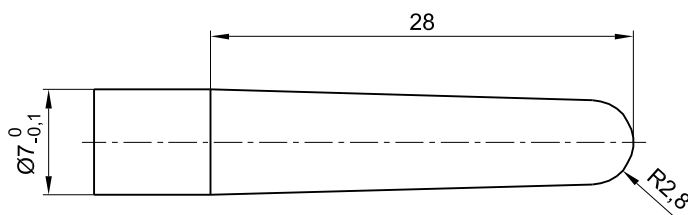

Figure 1 a— 7 mm probe

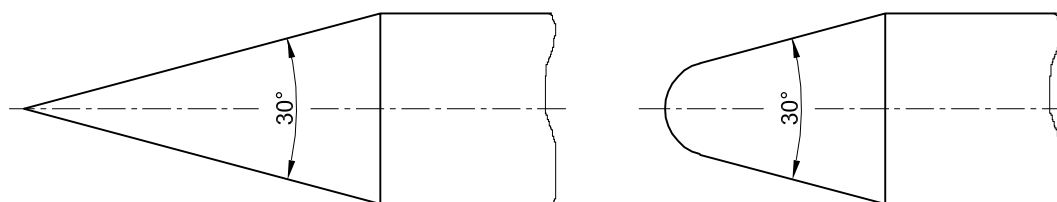

Figure 1 b — Conical probes

iTeh STANDARD PREVIEW



SIST EN 716-2:2008

<https://standards.iteh.ai/catalog/standards/sist/779664d3-b149-49ac-bef1-fc1000000000/sist-en-716-2-2008>

Figure 1 c — Cylindrical probes

#### Key

1 Ø 5 mm (-0,1/+0 mm), Ø 7 mm (-0,1/+0 mm), Ø 12 mm (0/+0,1 mm), Ø 18 mm (0/+0,1 mm)

Figure 1

## 4.2 Bottom impactor

An impactor with a total mass of 10 kg of hardwood or equivalent material with a hemispherical end and with dimensions in accordance with Figure 2.

The impactor shall be guided so that it is kept vertical and always falls on the impact point.

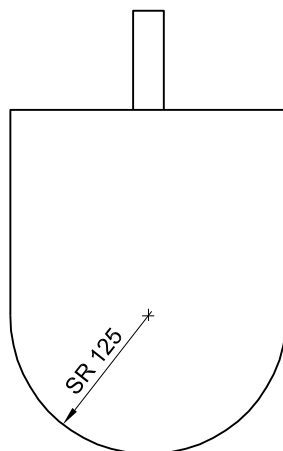

Figure 2 — Bottom impactor

#### 4.3 Test mattress

A PUR foam sheet with a thickness of 60 mm, a bulk density of  $(35 \pm 2) \text{ kg/m}^3$  and an indentation hardness index of  $(170 \pm 40) \text{ N}$  in accordance with A.40 of EN ISO 2439:2000 and being at least  $400 \text{ mm} \times 800 \text{ mm}$  in area but not larger than the mattress base of the cot under test. The test mattress shall have a cotton cover with a mass per unit area of  $100 \text{ g/m}^2$  to  $120 \text{ g/m}^2$ .

#### 4.4 Side impactor

SIST EN 716-2:2008

A pendulum with a cylindrical head made of steel (Figure 3). The head of the pendulum shall be surrounded by a 10 mm thick layer of rubber of hardness 76 IRHD to 78 IRHD in accordance with ISO 7619-2. The total mass shall be 2 kg.

Dimensions in millimetres

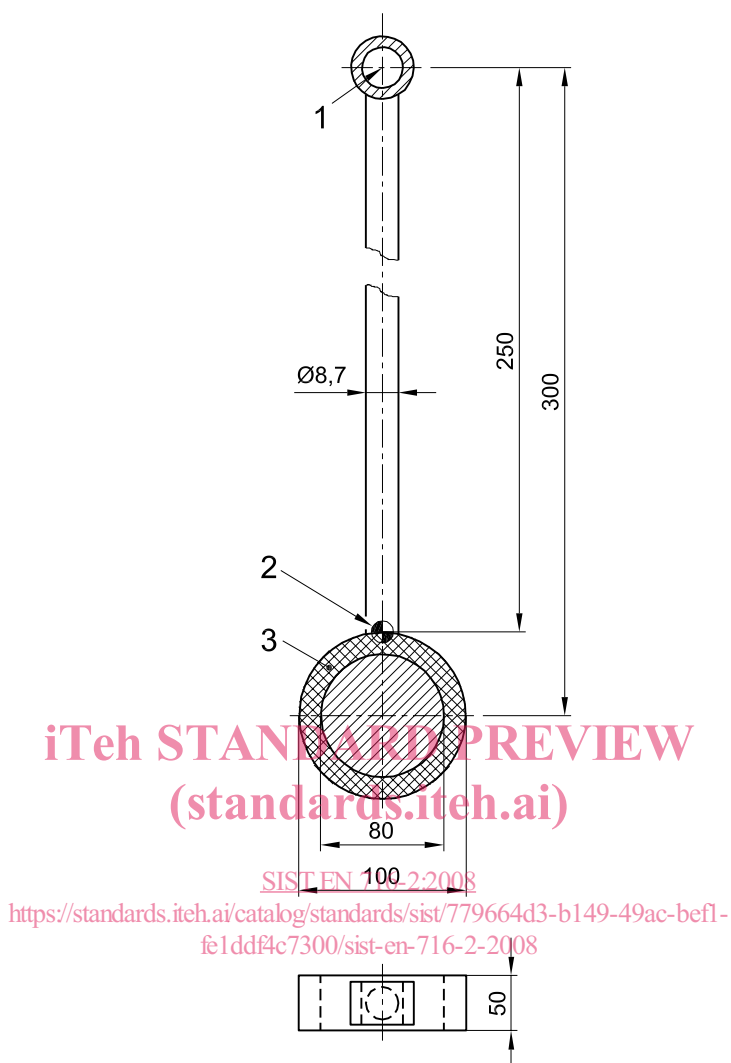
**Key**

- 1 Pivot point
- 2 Centre of gravity
- 3 Rubber 76 to 78 IRHD

**Figure 3 — Side impactor****4.5 Loading pad**

A rigid cylindrical object, 100 mm in diameter, having a smooth hard surface and rounded edge with radius of 12 mm.

**4.6 Stops**

Stops which prevent the article from sliding but not tilting, not higher than 12 mm except in cases where the design of the item necessitates the use of higher stops, in which case the lowest that will prevent the item from sliding shall be used.

## EN 716-2:2008 (E)

## 4.7 Floor surface

Rigid, horizontal and flat surface.

## 4.8 Test chain and mass

Ball chain with a ball diameter of  $(3,2 \pm 0,2)$  mm and a distance between ball centres of  $(4,0 \pm 0,2)$  mm (Figure 4), fixed to a 2,5 kg spherical weight with a diameter of 115 mm forming a loop in accordance with Figure 5.

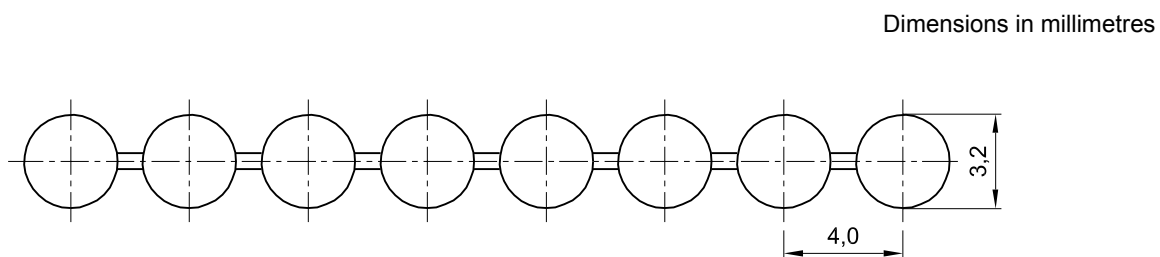
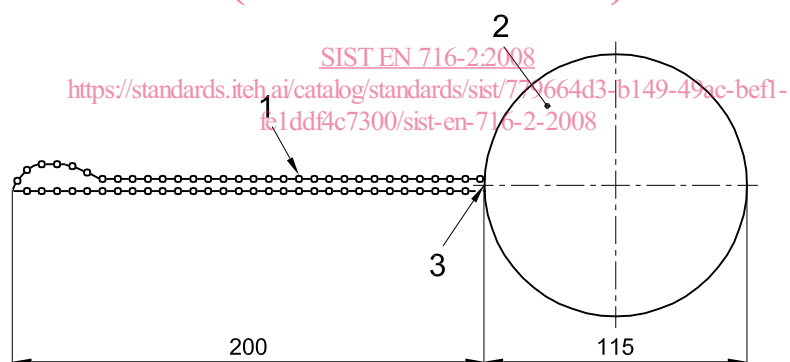

Figure 4 — Ball chain

**iTeh STANDARD PREVIEW**  
(standards.iteh.ai)

Dimensions in millimetres



**Key**

- 1 Ball chain
- 2 Weight, mass 2,5 kg
- 3 Fixing point

Figure 5 — Test chain and mass

## 4.9 Small parts cylinder

For assessment of small components, having dimensions in accordance with Figure 6.

NOTE The cylinder is identical to the one specified in EN 71-1 [1].