



**SLOVENSKI STANDARD**  
**SIST EN 15436-2:2008**

**01-november-2008**

---

**Oprema za vzdrževalna dela zimske službe in službe za vzdrževanje cest - 2. del:  
Ocenjevanje delovanja**

Road service area maintenance equipment - Part 2: Performance assessment

Straßenbetriebsdienstausstattung - Teil 2: Leistungsbewertung

Matériel d'entretien des dépendances routières - Partie 2: Evaluation des performances

**ITeH STANDARD PREVIEW**  
**(standards.iteh.ai)**

**Ta slovenski standard je istoveten z: EN 15436-2:2008**

SIST EN 15436-2:2008  
<https://standards.iteh.ai/catalog/standards/sist/cefl0251-d781-4f59-8f6d-2ae2aca69715/sist-en-15436-2-2008>

---

**ICS:**

43.160      Vozila za posebne namene      Special purpose vehicles

**SIST EN 15436-2:2008**

**en**

**iTeh STANDARD PREVIEW**  
**(standards.iteh.ai)**

SIST EN 15436-2:2008

<https://standards.iteh.ai/catalog/standards/sist/cefl0251-d781-4f59-8f6d-2ae2aca69715/sist-en-15436-2-2008>

EUROPEAN STANDARD  
NORME EUROPÉENNE  
EUROPÄISCHE NORM

**EN 15436-2**

August 2008

ICS 43.160

English Version

## Road service area maintenance equipment - Part 2: Performance assessment

Matériel d'entretien des dépendances routières - Partie 2:  
Evaluation des performances

Straßenbetriebsdienstausstattung - Teil 2:  
Leistungsbewertung

This European Standard was approved by CEN on 21 June 2008.

CEN members are bound to comply with the CEN/CENELEC Internal Regulations which stipulate the conditions for giving this European Standard the status of a national standard without any alteration. Up-to-date lists and bibliographical references concerning such national standards may be obtained on application to the CEN Management Centre or to any CEN member.

This European Standard exists in three official versions (English, French, German). A version in any other language made by translation under the responsibility of a CEN member into its own language and notified to the CEN Management Centre has the same status as the official versions.

CEN members are the national standards bodies of Austria, Belgium, Bulgaria, Cyprus, Czech Republic, Denmark, Estonia, Finland, France, Germany, Greece, Hungary, Iceland, Ireland, Italy, Latvia, Lithuania, Luxembourg, Malta, Netherlands, Norway, Poland, Portugal, Romania, Slovakia, Slovenia, Spain, Sweden, Switzerland and United Kingdom.

[SIST EN 15436-2:2008](https://standards.iteh.ai/catalog/standards/sist/cefl0251-d781-4f59-8fd-2ae2aca69715/sist-en-15436-2-2008)

<https://standards.iteh.ai/catalog/standards/sist/cefl0251-d781-4f59-8fd-2ae2aca69715/sist-en-15436-2-2008>



EUROPEAN COMMITTEE FOR STANDARDIZATION  
COMITÉ EUROPÉEN DE NORMALISATION  
EUROPÄISCHES KOMITEE FÜR NORMUNG

Management Centre: rue de Stassart, 36 B-1050 Brussels

## Contents

Page

Foreword.....	4
Introduction .....	5
1 Scope .....	6
2 Normative references .....	6
3 Terms and definitions .....	6
4 Cutting specifications check .....	6
4.1 Articulated-arm grass cutter – brushcutter .....	6
4.1.1 Cutting width (w).....	6
4.1.2 Cutting height (h).....	6
4.1.3 Cutting rotor stop time.....	6
4.2 In-line flail mower.....	7
4.2.1 Cutting width (w).....	7
4.2.2 Cutting height (h).....	7
4.2.3 Cutting tool stop time.....	7
4.3 Mechanical plant cutting.....	7
4.3.1 Cutting width (w).....	7
4.3.2 Cutting tool stop time.....	8
5 Kinematic properties check.....	8
5.1 General.....	8
5.2 Articulated-arm grass cutters - brushcutters .....	9
5.2.1 General.....	9
5.2.2 Horizontal range (A).....	10
5.2.3 Embankment range (E).....	10
5.2.4 Ditch range (D <sub>1</sub> ).....	10
5.2.5 Ditch range with sliderail (D <sub>2</sub> ).....	10
5.2.6 Offset (S).....	13
5.2.7 Cutting head clearance angle.....	13
5.2.8 Cutting head rotation angle .....	13
5.3 In-line flail mower.....	13
5.3.1 General.....	13
5.3.2 Horizontal range (A).....	14
5.3.3 Horizontal clearance (D <sub>h</sub> ) .....	14
5.3.4 Embankment range (R = E + F).....	14
5.3.5 Ditch range (D = E + F) .....	15
5.3.6 Cutting head clearance angle.....	15
5.4 Mechanical plant cutting.....	15
5.4.1 General.....	15
5.4.2 Vertical range (B) .....	16
5.4.3 Hedge side range (I) .....	16
5.4.4 Hedge side position variation Δ (I).....	17
5.4.5 Maximum hedge topping height (C).....	17
5.4.6 Offset (D <sub>p</sub> ) .....	17
5.4.7 Cutting head clearance angle.....	18
6 Weights and dimensions check .....	18
6.1 General.....	18
6.2 Transport dimensions .....	20
6.2.1 General.....	20
6.2.2 Height (H).....	20

6.2.3	Width (L1 + L2).....	20
6.2.4	Length (Lg <sub>1</sub> + Lg <sub>2</sub> ) .....	20
6.3	Total machine weight.....	20
7	Specifications check for machines driven over PTO shaft with mechanical or hydraulic power transmission.....	21
7.1	General .....	21
7.2	Measurements to be performed and data required .....	21
7.2.1	Hydraulic circuit oil temperature .....	21
7.2.2	Machine power supply .....	21
7.2.3	Cutting tool rotational speed .....	21
7.2.4	Cutting tool rotating torque.....	21
7.2.5	Cutting tool circumferential speed .....	22
7.2.6	Cutting head kinetic energy .....	22
7.3	Determination of power .....	22
7.3.1	General .....	22
7.3.2	Parameters to be measured .....	23
7.3.3	Equation to be applied .....	23
7.4	Performance characteristics .....	23
7.4.1	General .....	23
7.4.2	Maximum continuous power.....	23
7.4.3	Maximum instantaneous power.....	24
8	Specifications check for machines with power supplied by the carrying vehicle hydraulics.....	25
8.1	General .....	25
8.2	Measurements to be performed and data required .....	25
8.2.1	Hydraulic circuit oil temperature .....	25
8.2.2	Machine power supply .....	25
8.2.3	Cutting tool rotational speed .....	25
8.2.4	Cutting tool rotating torque.....	25
8.2.5	Cutting tool circumferential speed .....	26
8.2.6	Cutting tool kinetic energy .....	26
8.3	Determination of power .....	26
8.3.1	General .....	26
8.3.2	Parameters to be measured .....	26
8.3.3	Formula to be applied .....	27
8.4	Performance characteristics .....	27
8.4.1	General .....	27
8.4.2	Maximum continuous power.....	27
8.4.3	Maximum instantaneous power.....	28
Annex A (informative)	Presentation of results – articulated-arm grass cutters – brushcutters.....	29
Annex B (informative)	Presentation of results – in-line flail mowers .....	32
Annex C (informative)	Presentation of results – mechanical plant cutting .....	34
Bibliography.....		37

## Foreword

This document (EN 15436-2:2008) has been prepared by Technical Committee CEN/TC 337 “Winter maintenance and road service area maintenance equipment”, the secretariat of which is held by AFNOR.

This European Standard shall be given the status of a national standard, either by publication of an identical text or by endorsement, at the latest by February 2009, and conflicting national standards shall be withdrawn at the latest by February 2009.

Attention is drawn to the possibility that some of the elements of this document may be the subject of patent rights. CEN [and/or CENELEC] shall not be held responsible for identifying any or all such patent rights.

According to the CEN/CENELEC Internal Regulations, the national standards organizations of the following countries are bound to implement this European Standard: Austria, Belgium, Bulgaria, Cyprus, Czech Republic, Denmark, Estonia, Finland, France, Germany, Greece, Hungary, Iceland, Ireland, Italy, Latvia, Lithuania, Luxembourg, Malta, Netherlands, Norway, Poland, Portugal, Romania, Slovakia, Slovenia, Spain, Sweden, Switzerland and the United Kingdom.

## iTeh STANDARD PREVIEW (standards.iteh.ai)

SIST EN 15436-2:2008

<https://standards.iteh.ai/catalog/standards/sist/cefl0251-d781-4f59-8fd-2ae2aca69715/sist-en-15436-2-2008>

## Introduction

Road service area grass-cutting, brush-cutting and mechanical plant-cutting operations require special equipment that meets clearly defined technical criteria. This European Standard defines and describes the test methods used to monitor, assess and measure the technical performance of new equipment (head of series) in its working configuration with the production-run requirements tool.

The accuracies indicated in this European Standard apply only to the measurements taken to assess the performance of the machines away from the plants.

## iTeh STANDARD PREVIEW (standards.iteh.ai)

[SIST EN 15436-2:2008](https://standards.iteh.ai/catalog/standards/sist/cefl0251-d781-4f59-8fd-2ae2aca69715/sist-en-15436-2-2008)

<https://standards.iteh.ai/catalog/standards/sist/cefl0251-d781-4f59-8fd-2ae2aca69715/sist-en-15436-2-2008>

**EN 15436-2:2008 (E)****1 Scope**

This European Standard specifies the accuracy of the performance measurement system of road service area maintenance equipment described in the scope of CEN/TC 337 and used for:

- grass-cutting and brush-cutting;
- mechanical plant-cutting.

This equipment is mounted on self-propelled carrying vehicles and is designed to cut and shred grass, brushwood, trees, saplings and bushes in road service areas.

This European Standard does not cover the collection and transportation of shredded grass.

**2 Normative references**

The following referenced documents are indispensable for the application of this document. For dated references, only the edition cited applies. For undated references, the latest edition of the referenced document (including any amendments) applies.

EN 15436-1:2008, *Road service area maintenance equipment — Part 1: Terminology*

**iTeh STANDARD PREVIEW**  
(standards.iteh.ai)

**3 Terms and definitions**

For the purposes of this document, the terms and definitions given in EN 15436-1:2008 apply.

[SIST EN 15436-2:2008](https://standards.iteh.ai/catalog/standards/sist/cefl0251-d781-4f59-8f6d-2ae2aca69715/sist-en-15436-2-2008)

[https://standards.iteh.ai/catalog/standards/sist/cefl0251-d781-4f59-8f6d-](https://standards.iteh.ai/catalog/standards/sist/cefl0251-d781-4f59-8f6d-2ae2aca69715/sist-en-15436-2-2008)

**4 Cutting specifications check** [2ae2aca69715/sist-en-15436-2-2008](https://standards.iteh.ai/catalog/standards/sist/cefl0251-d781-4f59-8f6d-2ae2aca69715/sist-en-15436-2-2008)**4.1 Articulated-arm grass cutter – brushcutter****4.1.1 Cutting width (w)**

Cutting width is defined according to 6.25 of EN 15436-1:2008.

It is measured with an accuracy of  $\pm 0,01$  m and expressed in metres (m).

**4.1.2 Cutting height (h)**

Cutting height is defined according to 6.26 of EN 15436-1:2008.

It is measured with an accuracy of  $\pm 0,005$  m and expressed in metres (m).

In the case of continuous adjustment, the minimum and maximum heights should be measured. In the case of intermittent adjustment, the various possible heights allowed by the cutting tool should be measured.

**4.1.3 Cutting rotor stop time**

The cutting rotor stop time is measured automatically, from the time the stop command is sent to the moment when the rotation speed is measured as being equal to 0.

The cutting rotor stop time is measured with an accuracy of  $\pm 0,1$  s and expressed in seconds (s).



A distinction is made between the value of the stop times for open hydraulic circuits and for closed hydraulic circuits.

## 4.2 In-line flail mower

### 4.2.1 Cutting width (w)

The cutting width is measured with an accuracy of  $\pm 0,01$  m and expressed in metres (m).

### 4.2.2 Cutting height (h)

The cutting height is measured with an accuracy of  $\pm 0,005$  m and expressed in metres (m).

In the case of continuous adjustment, the minimum and maximum heights should be measured. In the case of intermittent adjustment, the various possible heights allowed by the cutting tool should be measured.

### 4.2.3 Cutting tool stop time

The cutting rotor stop time is measured automatically, from the time the stop command is sent to the moment when the rotation speed is measured as being equal to 0.

The cutting rotor stop time is measured with an accuracy of  $\pm 0,1$  s and expressed in seconds (s).

A distinction is made between the value of the stop times for open hydraulic circuits and for closed hydraulic circuits.

## 4.3 Mechanical plant cutting

### 4.3.1 Cutting width (w)

The cutting width is measured with the engine off.

The cutting width is the distance measured between the active ends of the fingers of the bars, with the cutters of the blades or saws in the furthest possible position (Figure 1).

The cutting width is measured with an accuracy of  $\pm 0,01$  m and expressed in metres (m).

ITeH STANDARD PREVIEW  
(standards.iteh.ai)

SIST EN 15436-2:2008

<https://standards.iteh.ai/catalog/standards/sist/cefl0251-d781-4f59-8fd-2ae2aca69715/sist-en-15436-2-2008>

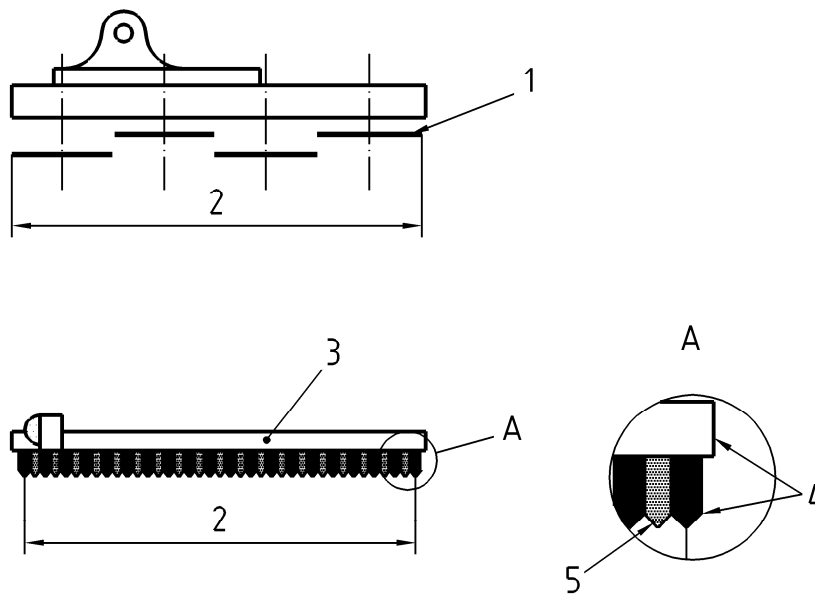
**Key**

- 1 saw blade
- 2 cutting width  $w$
- 3 reciprocating cutter bar
- 4 fixed
- 5 mobile

**iTeh STANDARD PREVIEW**  
(standards.iteh.ai)

SIST EN 15436-2:2008

<https://standards.iteh.ai/catalog/standards/sist/c6f10251-d781-4f59-8f6d-2ac2aca69715/sist-en-15436-2-2008>

**Figure 1 — Cutting width ( $w$ )**

**4.3.2 Cutting tool stop time**

The cutting tool stop time is measured automatically, from the time the stop command is sent to the moment when the rotation speed is measured as being equal to 0.

The cutting rotor stop time is measured with an accuracy of  $\pm 0,1$  s and expressed in seconds (s).

A distinction is made between the value of the stop times for open hydraulic circuits and for closed hydraulic circuits.

**5 Kinematic properties check****5.1 General**

In their design structure, these machines all have the same constituent elements, i.e. a frame, articulated arms and a tool. Whatever the shape and size of the components and any accessories that may be used, there is always an articulation between the frame and the primary arm. The articulation which is very close to the frame is used to define three reference planes for the machine.

The kinematic properties of the different machines are then defined with respect to these reference planes.

See definitions according to 5.1 to 5.6 of EN 15436-1:2008.

Given that the height, in relation to the ground plane of the primary arm–frame articulation changes the geometry of certain operating positions significantly, the horizontal reference plane of the machine is positioned at a height **ZP** from the ground specified by the manufacturer. This height can vary.

See definitions according to Clause 4 of EN 15436-1:2008.

## 5.2 Articulated-arm grass cutters - brushcutters

### 5.2.1 General

The kinematic properties defining the operating positions are shown in the diagram in Figure 2. They are described in the subclauses below.

Point **X** is defined at a distance of 1,10 m from the mid-plane.

Dimension **XP**, defined in 4.2 of EN 15436-1:2008, is specified by the manufacturer with an accuracy of  $\pm 0,01$  m.

Dimension **ZP**, defined in 4.4 of EN 15436-1:2008, is specified by the manufacturer with an accuracy of  $\pm 0,02$  m.

Dimension **YP**, defined in 4.3 of EN 15436-1:2008, is specified by the manufacturer with an accuracy of  $\pm 0,01$  m.

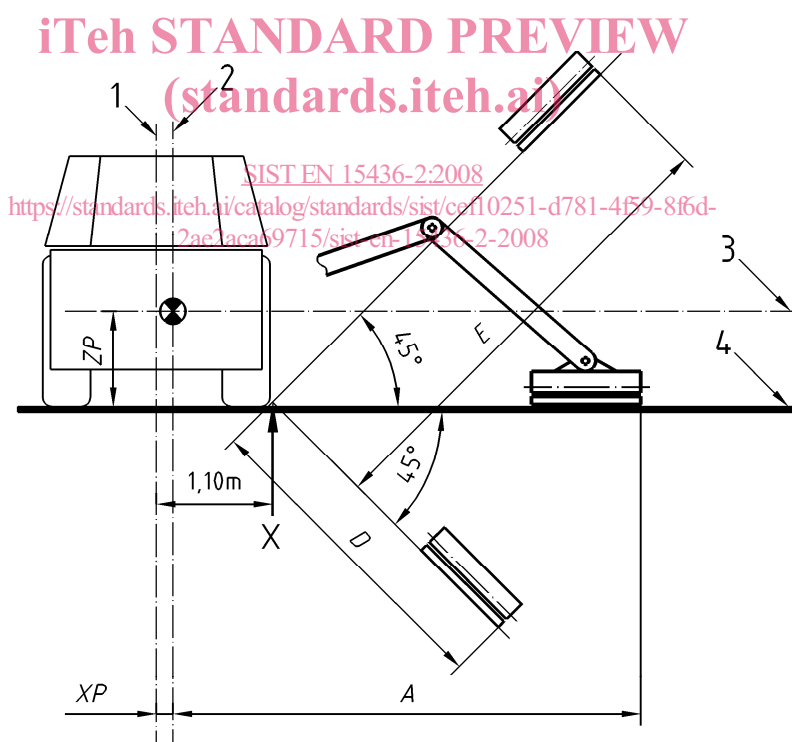

#### Key

- 1 mid-plane
- 2 Ivvp
- 3 hrp
- 4 ground plane

Figure 2 — Kinematic properties

**EN 15436-2:2008 (E)****5.2.2 Horizontal range (A)**

Horizontal range is defined in 6.21 of EN 15436-1:2008.

The measurement system accuracy of the horizontal distance **A** is  $\pm 0,01$  m.

**5.2.3 Embankment range (E)**

Embankment range is defined in 6.22 of EN 15436-1:2008.

The measurement system accuracy of the embankment range **E** is  $\pm 0,02$  m.

The embankment range **E** is measured on the  $45^\circ$  inclined plane on which the cutting head rests. The inclined plane is positioned at **X** on the ground plane. The angle of  $45^\circ$  is measured with an inclinometer and the measurement system accuracy of the inclination is  $\pm 1^\circ$ . The inclined plane allows the range **E** to be measured directly.

**5.2.4 Ditch range (D<sub>1</sub>)**

Ditch range is defined in 6.23 of EN 15436-1:2008.

The measurement system accuracy of the ditch range **D<sub>1</sub>** is  $\pm 0,02$  m.

The ditch range **D<sub>1</sub>** can be measured on the  $45^\circ$  inclined plane on which the cutting head rests. The inclined plane is positioned at **X** with respect to the ground plane. The angle of  $45^\circ$  is measured with an inclinometer and the measurement system accuracy of the inclination is  $\pm 1^\circ$ . The inclined plane allows the range **D<sub>1</sub>** to be measured directly.

**5.2.5 Ditch range with sliderail (D<sub>2</sub>)**

SIST EN 15436-2:2008

<https://standards.iteh.ai/catalog/standards/sist/cefl0251-d781-4f59-8fd-2ae2aca69715/sist-en-15436-2-2008>

**5.2.5.1 General**

Ditch range with sliderail is defined in 6.24 of EN 15436-1:2008.

The measurement system accuracy of the ditch range **D<sub>2</sub>** is  $\pm 0,02$  m.

The ditch range with sliderail **D<sub>2</sub>** can be measured on a  $45^\circ$  inclined plane 2,1 m from the mid-plane. The angle of  $45^\circ$  is measured with an inclinometer and the measurement system accuracy of the inclination is  $\pm 1^\circ$ . The inclined plane allows the range **D<sub>2</sub>** to be measured directly.