



**SLOVENSKI STANDARD**  
**SIST EN 1482-1:2007**

**01-september-2007**

**BUXca Yý U**

**SIST EN 1482:1998**

**SIST EN 1482:1998/AC:1998**

---

; bc [U]b`gfYXghj UnUdb`Yb`Y!`Jncf Yb`Y]b`df]dfUj Uj ncfWj `!`%`XY. `Jncf Yb`Y

Fertilizers and liming materials - Sampling and sample preparation - Part 1: Sampling

Düngemittel und Calcium-/Magnesium-Bodenverbesserungsmittel - Probenahme und Probenvorbereitung - Teil 1: Probenahme

(standards.iteh.ai)

Engrais et amendements minéraux basiques - Echantillonnage et préparation de l'échantillon - Partie 1: Echantillonnage

<https://standards.iteh.ai/catalog/standards/sist/ae492059-1236-49db-b432-148c1b089f5/sist-en-1482-1-2007>

**Ta slovenski standard je istoveten z: EN 1482-1:2007**

---

**ICS:**

65.080

Gnojila

Fertilizers

**SIST EN 1482-1:2007**

**en,fr,de**

**iTeh STANDARD PREVIEW**  
**(standards.iteh.ai)**

SIST EN 1482-1:2007

<https://standards.iteh.ai/catalog/standards/sist/ae492059-1236-49db-b432-14f8c1b089f5/sist-en-1482-1-2007>

English Version

## Fertilizers and liming materials - Sampling and sample preparation - Part 1: Sampling

Engrais et amendements minéraux basiques -  
Echantillonnage et préparation des échantillons - Partie 1:  
Echantillonnage

Düngemittel und Calcium-/Magnesium-  
Bodenverbesserungsmittel - Probenahme und  
Probenvorbereitung - Teil 1: Probenahme

This European Standard was approved by CEN on 15 December 2006.

CEN members are bound to comply with the CEN/CENELEC Internal Regulations which stipulate the conditions for giving this European Standard the status of a national standard without any alteration. Up-to-date lists and bibliographical references concerning such national standards may be obtained on application to the CEN Management Centre or to any CEN member.

This European Standard exists in three official versions (English, French, German). A version in any other language made by translation under the responsibility of a CEN member into its own language and notified to the CEN Management Centre has the same status as the official versions.

CEN members are the national standards bodies of Austria, Belgium, Bulgaria, Cyprus, Czech Republic, Denmark, Estonia, Finland, France, Germany, Greece, Hungary, Iceland, Ireland, Italy, Latvia, Lithuania, Luxembourg, Malta, Netherlands, Norway, Poland, Portugal, Romania, Slovakia, Slovenia, Spain, Sweden, Switzerland and United Kingdom.

[SIST EN 1482-1:2007](https://standards.iteh.ai/catalog/standards/sist/ae492059-1236-49db-b432-148c1b089f5/sist-en-1482-1-2007)

<https://standards.iteh.ai/catalog/standards/sist/ae492059-1236-49db-b432-148c1b089f5/sist-en-1482-1-2007>



EUROPEAN COMMITTEE FOR STANDARDIZATION  
COMITÉ EUROPÉEN DE NORMALISATION  
EUROPÄISCHES KOMITEE FÜR NORMUNG

Management Centre: rue de Stassart, 36 B-1050 Brussels

## Contents

Page

Foreword.....	3
Introduction .....	4
1 Scope .....	6
2 Normative references .....	6
3 Terms and definitions .....	6
4 Sampling plans and quantitative data .....	7
5 Incremental sampling methods.....	10
6 Reduction of aggregate sample .....	25
7 Division into final samples .....	26
8 Practical arrangements for final (laboratory) samples .....	26
9 Sampling report .....	27
Annex A (normative) Test for bias in mechanical samplers.....	29
Annex B (informative) Examples of rotating sample dividers.....	32
Annex C (normative) Test for bias in a rotary divider.....	35
Annex D (informative) Examples of apparatus for sampling fluid fertilizers .....	36
Annex E (normative) Methods of mixing for fluid fertilizers.....	44
Bibliography .....	51

iTech STANDARD PREVIEW

(standards.itech.ai)

SIST EN 1482-1:2007

[https://standards.itech.ai/catalog/standards/sist/ae492059-1236-49db-b432-](https://standards.itech.ai/catalog/standards/sist/ae492059-1236-49db-b432-1482-1-2007)

[1482-1-2007](https://standards.itech.ai/catalog/standards/sist/ae492059-1236-49db-b432-1482-1-2007)

## Foreword

This document (EN 1482-1:2007) has been prepared by Technical Committee CEN/TC 260 “Fertilizers and liming materials”, the secretariat of which is held by DIN.

This European Standard shall be given the status of a national standard, either by publication of an identical text or by endorsement, at the latest by July 2007, and conflicting national standards shall be withdrawn at the latest by July 2007.

Together with Part 2, this document supersedes EN 1482:1996.

This European Standard has been prepared under a mandate given to CEN by the European Commission and the European Free Trade Association to provide a means of conforming to Essential Requirements of the Regulation (EC) No 2003/2003 of the European Parliament and of the Council of 13 October 2003 relating to fertilizers.

EN 1482, Fertilizers and liming materials — Sampling and sample preparation” consists of two parts:

- Part 1: Sampling
- Part 2: Sample preparation

According to the CEN/CENELEC Internal Regulations, the national standards organizations of the following countries are bound to implement this European Standard: Austria, Belgium, Bulgaria, Cyprus, Czech Republic, Denmark, Estonia, Finland, France, Germany, Greece, Hungary, Iceland, Ireland, Italy, Latvia, Lithuania, Luxembourg, Malta, Netherlands, Norway, Poland, Portugal, Romania, Slovakia, Slovenia, Spain, Sweden, Switzerland and United Kingdom.

## Introduction

This European Standard (EN 1482-1) covers the following aspects of sampling, derived from the International Standards and documents indicated but presented in a simplified and condensed form. The titles of the International Standards are given in the Bibliography.

- Sampling plans and quantitative data: ISO 8634, ISO/TR 5307, ISO/TR 7553 and EEC 77/535 (superseded by Regulation (EC) No 2003/2003).
- Sampling methods: ISO 3963, and EEC 77/535 (superseded by Regulation (EC) No 2003/2003).
- Reduction: ISO 7410, ISO 7742, ISO 8358 and EEC 77/535 (superseded by Regulation (EC) No 2003/2003).
- Sampling reports: ISO 5306 and EEC 77/535 (superseded by Regulation (EC) No 2003/2003).

EN 1482-2 covers the reduction and preparation of samples for analysis.

Figure 1 gives a schematic diagram of the sampling and sample preparation process for solids.

The fundamental principle of representative sampling is that every particle has an equal chance of being selected or rejected. This principle cannot easily be complied with in the case of bulk heaps of solid fertilizers or large storage tanks of fluid fertilizers as the majority of the material cannot be reached by any sampling device. The fertilizer in these cases should be sampled during transfer, during the building up of the heap, during the filling of the storage tank, during dispatch or where it is being moved solely for sampling purposes.

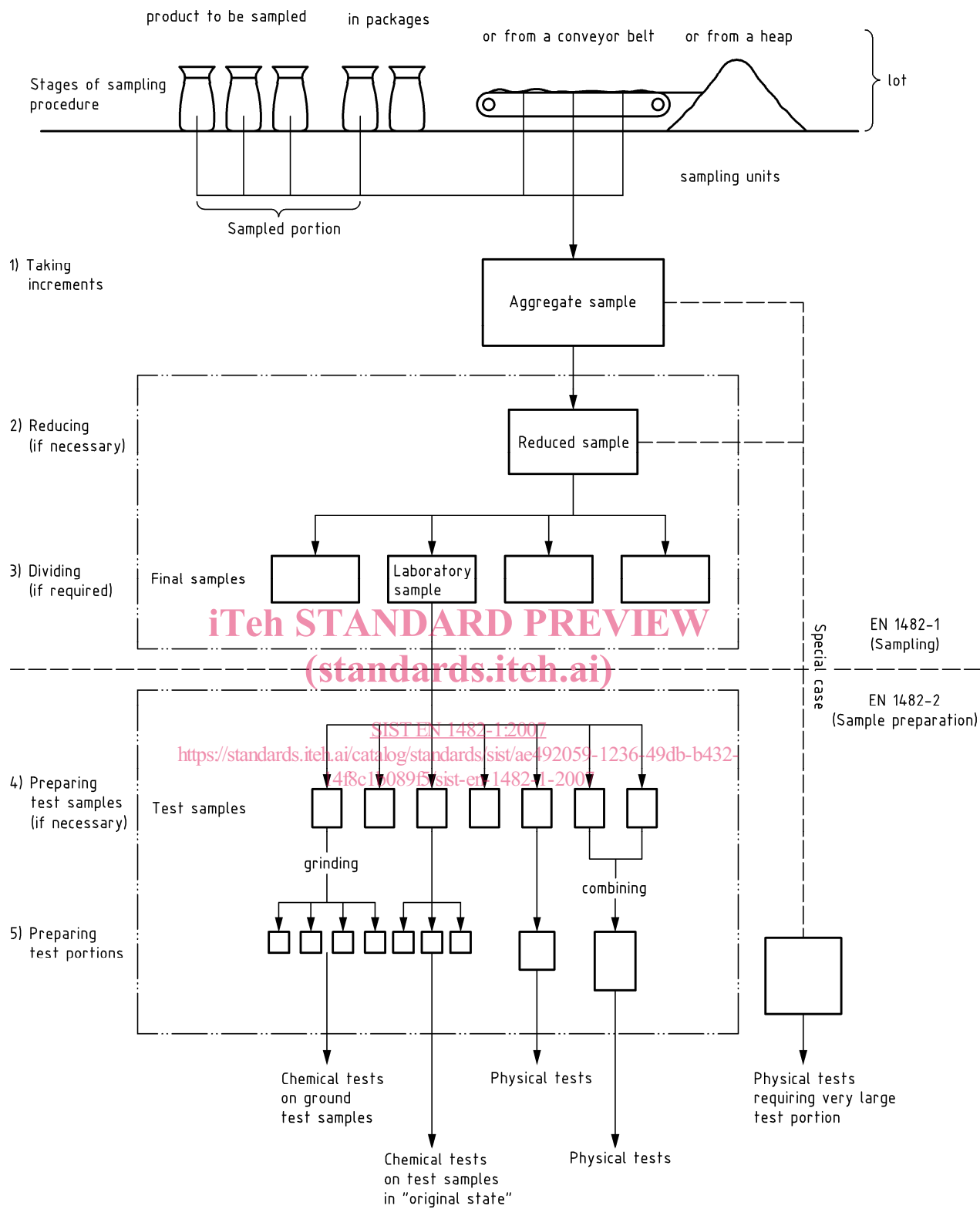

Figure 1 — Schematic diagram of sampling process for solids

## 1 Scope

This European Standard specifies sampling plans and methods of representative sampling of fertilizers and liming materials to obtain samples for physical and chemical analysis, from packages and containers up to and including 1 000 kg, from fluid products and from fertilizers in bulk provided the product is in motion.

It is applicable to the sampling of lots of fertilizer or liming material supplied or ready for supply to third parties, as such, or in smaller lots, each of which would be subject to local, national or regional legislation. Where legislation so requires, samples are taken in accordance with this European Standard.

NOTE The term fertilizer is used throughout the body of this European Standard and should be taken to include liming materials unless otherwise indicated.

This European Standard does not cover complete, statistical sampling plans.

## 2 Normative references

The following referenced documents are indispensable for the application of this document. For dated references, only the edition cited applies. For undated references, the latest edition of the referenced document (including any amendments) applies.

EN 1235, *Solid fertilizers — Test sieving (ISO 8397:1988 modified)*

ISO 2602, *Statistical interpretation of test results — Estimation of the mean — Confidence interval*

ISO 3310-1, *Test sieves — Technical requirements and testing — Part 1: Test sieves of metal wire cloth*

## 3 Terms and definitions

SIST EN 1482-1:2007

[https://standards.iteh.ai/catalog/standards/sist/ae492059-1236-49db-b432-](https://standards.iteh.ai/catalog/standards/sist/ae492059-1236-49db-b432-1482-10805/sist-en-1482-1-2007)

For the purposes of this document, the following terms and definitions apply.

### 3.1

#### **aggregate sample**

combination of all increments from the lot or sampled portion

NOTE The increments may be grouped together in equal numbers in order to form several aggregate samples which can be reduced and analysed separately.

### 3.2

#### **delivery**

quantity of material transferred at one time

### 3.3

#### **division**

process of producing a number of representative smaller portions, approximately equal in mass to each other, from a larger mass

### 3.4

#### **final sample**

representative part of the reduced sample or, where no intermediate reduction is required, of the aggregate sample

NOTE Often, more than one sample is prepared, at the same time, from the reduced sample (or from the aggregate sample). One or more of these final samples is used as a laboratory sample or as laboratory samples, while others may be stored for reference purposes.



**3.5****increment**

quantity of material taken from a sampling unit

NOTE An increment may be constituted from a number of sub samples.

**3.6****laboratory sample**

one final sample intended for laboratory inspection or testing

**3.7****lot**

total quantity of material, assumed to have the same characteristics, to be sampled using a particular sampling plan

**3.8****reduced sample**

representative part of the aggregate sample obtained by a process of reduction in such a manner that the mass is at least the mass of the required final samples

**3.9****reduction**

process of producing a representative smaller mass of fertilizer from a larger mass, with the remainder being discarded

**3.10****sampling unit**

defined quantity of material having a boundary, which can be physical or hypothetical

NOTE An example of a physical boundary is a container. An example of a hypothetical boundary is a time interval for a flow of material.

<https://standards.iteh.ai/catalog/standards/sist/ae492059-1236-49db-b432-14f8c1b089f5/sist-en-1482-1-2007>

**3.11****sampled portion**

quantity of a material consisting of all the sampling units from which increments are to be taken and having characteristics presumed to be uniform

**4 Sampling plans and quantitative data****4.1 General**

Correct sampling is a difficult operation which requires great care. The need to obtain a fully representative sample for both the chemical and physical testing of fertilizers cannot be stressed too much. Sampling plans have been produced to cover a range of quantities of fertilizer and these form the basis of International Standards (see Bibliography).

The sampling plans given in this European Standard are not based on strict statistical principles but samples obtained by following the procedures described in this clause shall be considered to be representative of the original lot or sampled portion.

This clause specifies sampling plans for the evaluation of deliveries of fertilizers as well as statutory control plans which have to be followed in certain circumstances.

For statutory control and the simple commercial evaluation of a small quantity of fertilizer, one final sample is sufficient but this may subsequently be divided into a number of identical samples.

For the commercial evaluation of a large delivery which is supplied for resale in smaller lots a number of samples representing parts of the delivery are required in order to assess the variability of the lot.

NOTE For example a delivery of 5 000 t should be treated as at least five deliveries of 1 000 t each and five separate samples should be collected and prepared. The determination in this European Standard is based on a simple relationship between the amount to be sampled and the minimum number of increments to be taken.

The methods of sampling to be used are described in Clause 5.

**4.2 Sampling plans**

**4.2.1 Determination of the number of sampling units which form the sampled portion**

**4.2.1.1 General**

The number of sampling units from which increments are to be taken depends on the size of the lot.

**4.2.1.2 Product in packages or containers**

In the case of product in packages or containers, the sampling unit is a package and the number of individual packages from which incremental samples are to be taken should be in accordance with Table 1. In this context a package is normally taken to hold no more than 50 kg – larger containers such as Intermediate Bulk Containers (IBC's) should be treated according to the procedure in 5.9 or 5.10. For packages weighing less than 1 kg each, it might be necessary to increase the number taken to ensure a sufficiently large aggregate sample.

iTeh STANDARD PREVIEW  
(standards.iTech.ai)

**Table 1 — Number of individual packages from which incremental samples are to be taken**

Lot size	Minimum number of sampling units
4 or fewer packages	All packages
More than 4 and up to 10 packages	4
More than 10 and up to 400 packages	The nearest whole number above the square root of the number of packages present.
More than 400 packages	20

**4.2.1.3 Product in bulk**

In the case of product in bulk, the number of sampling units from which incremental samples should be taken depends on the total mass present. The number of sampling units to be sampled should be in accordance with Table 2.

**Table 2 — Number of sampling units from which incremental samples are to be taken**

Lot size	Minimum number of sampling units
25 t or less	10
More than 25 t and up to 400 t	The nearest whole number above the square root of 4 times the number of tonnes present.
More than 400 t	40

## 4.2.2 Identification of the sampling units to be sampled

### 4.2.2.1 Solid and fluid fertilizer in packages or containers

Identify the packages in the lot or sampled portion consecutively and, by using a source of random numbers, select the packages from which incremental samples are to be taken and mark them.

### 4.2.2.2 Solid and fluid fertilizer in bulk during movement

Where the movement relates to loading or unloading using grabbing equipment such as a crane or automatic shovel loader, the sampling unit is the quantity of material corresponding to one grab. If the movement is a continuous operation such as on a conveyor belt or through a pipe, each sampling unit is made up of a mass of no more than 5 t.

Calculate the number of sampling units present from the total mass and by using a table of random numbers select the sampling units from which increments are to be taken during the movement. Number the sampling units in chronological order of their formation. Estimate the time taken for the material to pass the sampling point.

Divide this time into equal time intervals such that the number of intervals is at least twice the minimum number of sampling units to be sampled in accordance with Table 2 and each sampling unit is not more than 5 t. The time intervals are the sampling units. From these sampling units randomly select the number from which increments are to be taken. Within each of the selected sampling units randomly select a time at which the increment is to be taken.

NOTE As there will be some variation in the speed of the belt or the flow in the pipe and the quantity at any one point, it is recommended that the number of sampling units selected is at least 10 % more than the minimum in Table 2.

Automatic mechanical samplers normally work at fixed time intervals. In this case the increments are collected over the whole timescale and cannot be regarded as having been taken randomly. For legislative purposes the mechanical sampler shall be operated at the selected random times.

## 4.2.3 Collection of increments

### 4.2.3.1 General

All incremental samples shall be of approximately the same mass/volume.

### 4.2.3.2 Solid fertilizer in packages or containers up to and including 50 kg

Take one increment from each of the selected packages (sampling units 4.2.2.1), by the use of a divider (5.6 or 5.7) or by the manual method described in 5.8.

### 4.2.3.3 Product in intermediate bulk containers

Collect the relevant number of increments by using the method described in 5.9 and/or 5.10.

### 4.2.3.4 Solid fertilizer in bulk

Collect the relevant number of increments by using one of the methods described in 5.2 to 5.5.

### 4.2.3.5 Fluid fertilizers

Follow the appropriate procedure described in 5.11.

### 4.3 Quantitative data

#### 4.3.1 Mass of increments

Increments should normally be of at least 250 g each. For blended fertilizers and for liming materials coarser than 80 % passing 0,315 mm the minimum mass of each increment should be 500 g. For packages weighing 4 kg or less, the entire contents are taken as the increment.

#### 4.3.2 Mass of single aggregate/reduced samples

Combine and mix all the collected increments. When necessary, reduce the aggregate sample as described in Clause 6, so that the final mass for chemical testing is at least 2 kg and for physical testing at least 4 times the maximum amount required for the physical test method.

#### 4.3.3 Mass of multiple aggregate samples

Combine and mix all the collected increments for one sample before reduction to final samples. Each sample shall have at least a final mass equal to 4 times the maximum amount required for testing. Repeat this procedure for each sample.

#### 4.3.4 Mass of final sample

The mass of each final sample for chemical analysis shall be at least 500 g. For physical testing the mass is dependent on the test(s) to be carried out.

**iTeh STANDARD PREVIEW**  
(standards.iteh.ai)

## 5 Incremental sampling methods

### 5.1 General

[SIST EN 1482-1:2007](https://standards.iteh.ai/catalog/standards/sist/ae492059-1236-49db-b432-148c1b089f5/sist-en-1482-1-2007)

[https://standards.iteh.ai/catalog/standards/sist/ae492059-1236-49db-b432-](https://standards.iteh.ai/catalog/standards/sist/ae492059-1236-49db-b432-148c1b089f5/sist-en-1482-1-2007)

[148c1b089f5/sist-en-1482-1-2007](https://standards.iteh.ai/catalog/standards/sist/ae492059-1236-49db-b432-148c1b089f5/sist-en-1482-1-2007)

Packages of up to and including 50 kg in mass may be sampled by a process of reduction (see 5.6), starting with the total contents of the package, or by spear sampling from the selected packages but the latter only when the product is uniform or a single chemical (such as urea, ammonium nitrate or ammonium sulfate) and the sampling is only for chemical analysis. Intermediate bulk containers are best sampled by the method described in 5.9. All packages and IBC's may be sampled by emptying the contents as in the method described in 5.8.

Mechanical sampling devices, if installed in a transfer system, can be used to collect increments, provided they have been tested for the absence of bias (see Annex A) and the timing of the incremental samples can be controlled manually.

The sampling apparatus shall be clean, dry and inert (i.e. fabricated of materials which will not affect the characteristics of the fertilizers to be sampled).

All sampling operations should be carried out in such a way as to minimize changes to sample properties, e.g. moisture content.

### 5.2 Solid fertilizer in bulk being moved by conveyor belt - Stopping the belt method

#### 5.2.1 General

The sample is taken from a conveyor by stopping the belt.

Taking a representative sample from a consignment of fertilizer by sampling from a conveyor by stopping the belt is time-consuming and interrupts the loading or unloading process considerably. The method should, therefore, only be used if no other more convenient method is available.

NOTE This sampling technique is also used as a reference method to assess the accuracy of other techniques or apparatus.

**WARNING — This sampling method involves contact with machinery which is normally in motion. It is essential that precautions be taken so that there is no possibility of the conveyor starting up while the increments are being taken. An override start/stop button should be provided at the point of sampling.**

The sampler shall be able to reach the whole cross-section of the belt without undue physical strain. The position for sampling should be made as safe and convenient as possible, for example by using a suitable platform.

### 5.2.2 Principle

Stopping of the belt conveying the fertilizer. Insertion of two parallel rigid sheets into and at right angles to the stream of fertilizer and to the axis of the conveyor belt. Removal of the material between the sheets as an increment.

### 5.2.3 Apparatus

Two parallel rigid sheets, shaped to the characteristics of the trough of the belt, sufficiently long to project beyond the sides of the belt by about 500 mm and sufficiently wide for the upper edge to be at least 50 mm above the top of the fertilizer on the belt. It is recommended that a metal frame be made to carry the rigid sheets. This frame can then be placed across the belt in a single operation. Failing this, two marks should be made on the supporting structure on each side of the belt so that the sheets can be inserted in the same places each time.

iTeh STANDARD PREVIEW  
(standards.iteh.ai)

### 5.2.4 Procedure

Stop the belt at the times selected as described in 4.2.2.2. Once the belt has stopped, insert the two parallel rigid sheets at a sufficient distance apart to give an increment of at least 1 kg as follows:

<https://standards.iteh.ai/catalog/standards/sist/ac492059-1236-49db-b432-01015201-0000>

- a) if the conveyor belt is horizontal, insert the sheets vertically downwards into the stream of fertilizer;
- b) if the conveyor belt is inclined, insert the sheets quickly, at right angles to the stream, so as to avoid any backflow.

Push any fertilizer obstructing the insertion of the sheets as follows:

- a) in the case of the downstream sheet, into the sample;
- b) in the case of the upstream sheet, out of the sample.

As quickly as possible, completely remove the material between the two parallel rigid sheets into a suitable air-tight container.

Remove the sheets and make sure that nothing has been left on the belt which could cause damage further down. Restart the belt.

Repeat the process for each increment.

## 5.3 Solid fertilizer in bulk - Mechanical sampling whilst in motion

### 5.3.1 General

Mechanical sampling devices installed in a fertilizer handling system are a convenient means of collecting samples providing the timing of the taking of the incremental samples can be controlled manually to allow randomness in sampling times. A number of different types are available and this European Standard does

not recommend any particular type over another. All might be suitable provided they have been shown to be capable of operating without bias. Before any samples are taken by the device for control purposes, it should be checked for bias using the procedure described in Annex A.

The Annex A bias check test is applicable to any form of mechanical sampling device installed at some point in a bulk handling system, providing that either the fertilizer passes along a conveyor belt, before or after the device, or it is subsequently packed in bags in order that a reference collection can be made.

NOTE The mechanical sampling device may be used for the collection of samples for chemical analysis as well as for physical testing.

### **5.3.2 Procedure**

Obtain increments by operating the mechanical sampling device at the times selected as described in 4.2.2.2.

## **5.4 Solid fertilizer in bulk - Manual sampling from falling stream**

**WARNING — Manual sampling from bulk fertilizer in motion should only be undertaken when the operations can be performed safely.**

### **5.4.1 Principle**

Representative increments are taken by means of randomly timed cuts of the stream.

### **5.4.2 Apparatus**

To sample a free-falling stream as shown in Figure 2 a stainless steel sampling cup shall be used as shown in Figure 3. The length of the cup should be at least three times the depth of the falling stream to be sampled and the edges of the opening shall be thin to ensure a clean cut. The minimum capacity should be 500 g, the maximum capacity should be 5 kg. The width of the active opening of the cup shall be at least three times the maximum diameter of the particles of the product to be sampled.

### **5.4.3 Procedure**

Sample the fertilizer during the free fall by arranging the sampling cup in such a way that it passes horizontally through the falling stream. Ensure that the sampling cup extends completely through the stream (see Figure 2). Ensure that the sampling cup when not in use is protected from the stream.

Pass the cup through the stream at random times within each sampling unit as designated in accordance with 4.2.2.2, throughout the transfer operation. Make sure that passes are made at a uniform speed such that the cup is approximately half filled each time.

Empty the contents of the cup from each pass into a suitable air-tight container.

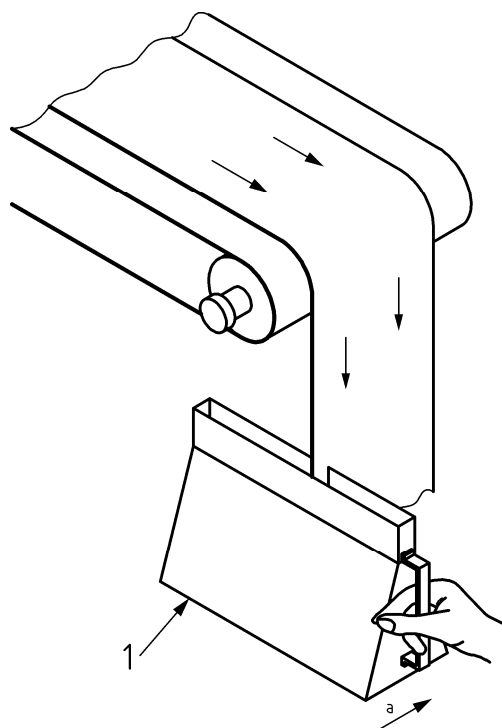
**Key**

- 1 sampling cup  
a direction of sampling cup movement

iTeh STANDARD PREVIEW  
(standards.iteh.ai)

SIST EN 1482-1:2007  
**Figure 2 — Method of sampling a free-falling stream**  
<https://standards.iteh.ai/catalog/standards/sist/ac492059-1236-49db-b452-148c1b089f5/sist-en-1482-1-2007>

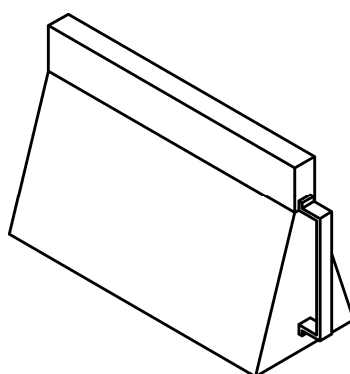

**Figure 3 — Example of stream sampling cup**

## 5.5 Solid fertilizer in bulk - Manual sampling method by moving the bulk

### 5.5.1 General

Where the fertilizer to be sampled is in a bulk static heap and is not to be moved at a time or by a method convenient for any of the other methods of sampling described above, then the heap will need to be moved by the sampling official.