



SLOVENSKI STANDARD
SIST-TS CEN/TS 15558:2008
01-marec-2008

HfXbU[bc^U!`8c`c Yj Ub^Yb]hfUbY[U]b`Ua cb]^j Y[UXi y]_Udc`I `gW i

Fertilizers - Determination of nitric and ammoniacal nitrogen according to Ulsch

Düngemittel - Bestimmung von Nitrat- und Ammoniumstickstoff nach Ulsch

Engrais - Détermination de l'azote nitrique et ammoniacal selon Ulsch

iTeh STANDARD PREVIEW

Ta slovenski standard je istoveten z: CEN/TS 15558:2007

[SIST-TS CEN/TS 15558:2008](https://standards.iteh.ai/catalog/standards/sist/cc9b143e-5181-4438-98e1-9f30316b3865/sist-ts-cen-ts-15558-2008)

<https://standards.iteh.ai/catalog/standards/sist/cc9b143e-5181-4438-98e1-9f30316b3865/sist-ts-cen-ts-15558-2008>

ICS:

65.080

SIST-TS CEN/TS 15558:2008

en,fr,de

iTeh STANDARD PREVIEW
(standards.iteh.ai)

SIST-TS CEN/TS 15558:2008

<https://standards.iteh.ai/catalog/standards/sist/cc9b143e-5181-4438-98e1-9f30316b3865/sist-ts-cen-ts-15558-2008>

ICS 65.080

English Version

Fertilizers - Determination of nitric and ammoniacal nitrogen according to Ulsch

Engrais - Détermination de l'azote nitrique et ammoniacal
selon Ulsch

Düngemittel - Bestimmung von Nitrat- und
Ammoniumstickstoff nach Ulsch

This Technical Specification (CEN/TS) was approved by CEN on 1 January 2007 for provisional application.

The period of validity of this CEN/TS is limited initially to three years. After two years the members of CEN will be requested to submit their comments, particularly on the question whether the CEN/TS can be converted into a European Standard.

CEN members are required to announce the existence of this CEN/TS in the same way as for an EN and to make the CEN/TS available promptly at national level in an appropriate form. It is permissible to keep conflicting national standards in force (in parallel to the CEN/TS) until the final decision about the possible conversion of the CEN/TS into an EN is reached.

CEN members are the national standards bodies of Austria, Belgium, Bulgaria, Cyprus, Czech Republic, Denmark, Estonia, Finland, France, Germany, Greece, Hungary, Iceland, Ireland, Italy, Latvia, Lithuania, Luxembourg, Malta, Netherlands, Norway, Poland, Portugal, Romania, Slovakia, Slovenia, Spain, Sweden, Switzerland and United Kingdom.

[SIST-TS CEN/TS 15558:2008](https://standards.iteh.ai/catalog/standards/sist/cc9b143e-5181-4438-98e1-9f30316b3865/sist-ts-cen-ts-15558-2008)

<https://standards.iteh.ai/catalog/standards/sist/cc9b143e-5181-4438-98e1-9f30316b3865/sist-ts-cen-ts-15558-2008>



EUROPEAN COMMITTEE FOR STANDARDIZATION
COMITÉ EUROPÉEN DE NORMALISATION
EUROPÄISCHES KOMITEE FÜR NORMUNG

Management Centre: rue de Stassart, 36 B-1050 Brussels

Contents

Page

Foreword.....	3
1 Scope	4
2 Normative references	4
3 Terms and definitions	4
4 Principle.....	4
5 Reagents.....	4
6 Apparatus	6
7 Sampling and sample preparation	11
8 Procedure	11
9 Calculation and expression of the result	13
10 Test report	13
Bibliography	14

iTeh STANDARD PREVIEW
(standards.iteh.ai)

[SIST-TS CEN/TS 15558:2008](https://standards.iteh.ai/catalog/standards/sist/cc9b143e-5181-4438-98e1-9f30316b3865/sist-ts-cen-ts-15558-2008)
<https://standards.iteh.ai/catalog/standards/sist/cc9b143e-5181-4438-98e1-9f30316b3865/sist-ts-cen-ts-15558-2008>

Foreword

This document (CEN/TS 15558:2007) has been prepared by Technical Committee CEN/TC 260 "Fertilizers and liming materials", the secretariat of which is held by DIN.

This document has been prepared under a mandate given to CEN by the European Commission and the European Free Trade Association.

According to the CEN/CENELEC Internal Regulations, the national standards organizations of the following countries are bound to announce this Technical Specification: Austria, Belgium, Bulgaria, Cyprus, Czech Republic, Denmark, Estonia, Finland, France, Germany, Greece, Hungary, Iceland, Ireland, Italy, Latvia, Lithuania, Luxembourg, Malta, Netherlands, Norway, Poland, Portugal, Romania, Slovakia, Slovenia, Spain, Sweden, Switzerland and the United Kingdom.

iTeh STANDARD PREVIEW (standards.iteh.ai)

SIST-TS CEN/TS 15558:2008

<https://standards.iteh.ai/catalog/standards/sist/cc9b143e-5181-4438-98e1-9f30316b3865/sist-ts-cen-ts-15558-2008>

1 Scope

This Technical Specification specifies a method for the determination of nitrate and ammoniacal nitrogen with reduction according to Ulsch.

The method is applicable to all nitrogenous fertilizers, including compound fertilizers, in which nitrogen is found exclusively in nitrate form, or in ammoniacal and nitrate form.

2 Normative references

The following referenced documents are indispensable for the application of this document. For dated references, only the edition cited applies. For undated references, the latest edition of the referenced document (including any amendments) applies.

EN 1482-2, *Fertilizers and liming materials — Sampling and sample preparation — Part 2: Sample preparation*

EN 12944-1:1999, *Fertilizers and liming materials and soil improvers — Vocabulary— Part 1: General terms*

EN 12944-2:1999, *Fertilizers and liming materials and soil improvers — Vocabulary— Part 2: Terms relating to fertilizers*

EN ISO 3696:1995, *Water for analytical laboratory use — Specification and test methods (ISO 3696:1987)*

iTeh STANDARD PREVIEW
(standards.iteh.ai)

3 Terms and definitions

[SIST-TS CEN/TS 15558:2008
https://standards.iteh.ai/catalog/standards/sist/cc9b143e-5181-4438-98e1-9f30316b3865/sist-ts-cen-ts-15558-2008](https://standards.iteh.ai/catalog/standards/sist/cc9b143e-5181-4438-98e1-9f30316b3865/sist-ts-cen-ts-15558-2008)

For the purposes of this document, the terms and definitions given in EN 12944-1:1999 and EN 12944-2:1999 apply.

4 Principle

Reduction of nitrates and nitrites to ammonia by means of metallic iron in an acid medium and displacement of the ammonia thus formed by the addition of an excess of sodium hydroxide: distillation of the ammonia and determination of the yield of ammonia in a known volume of standard sulfuric acid solution and titration of the excess sulfuric acid by means of a standard solution of sodium or potassium hydroxide.

5 Reagents

5.1 General

Use only reagents of recognized analytical grade and distilled or demineralized water, free from carbon dioxide and all nitrogenous compounds (grade 3 according to EN ISO 3696:1995).

5.2 Diluted hydrochloric acid

Mix one volume of concentrated hydrochloric acid solution, $\rho(\text{HCl}) = 1,18 \text{ g/ml}$, with one volume of water.

5.3 Sulfuric acid

$c = 0,05 \text{ mol/l}$

5.4 Sodium or potassium hydroxide solution

carbonate free, $c = 0,1 \text{ mol/l}$

5.5 Sulfuric acid solution

approximately 30 % H_2SO_4 (mass concentration), ammonia free

5.6 Powdered iron

Reduced in hydrogen (the prescribed quantity of iron shall be able to reduce at least 0,05 g of nitrate nitrogen)

5.7 Sodium hydroxide solution

30 % mass concentration, of approximately $\rho(\text{NaOH}) = 1,33 \text{ g/ml}$, ammonia free

5.8 Indicator solutions**5.8.1 Mixed indicator**

Solution A: Dissolve 1 g of methyl red in 37 ml of sodium hydroxide solution $c = 0,1 \text{ mol/l}$ and make up to 1 l with water.

Solution B: Dissolve 1 g of methylene blue in water and make up to 1 l.

Mix one volume of solution A with two volumes of solution B.

This indicator is violet in acid solution, grey in neutral solution and green in alkaline solution. Use 0,5 ml (10 drops) of this indicator solution.

5.8.2 Methyl red indicator solution

Dissolve 0,1 g of methyl red in 50 ml of 95 % ethanol. Make up to 100 ml with water and filter if necessary. This indicator may be used (4 to 5 drops) instead of that specified in 5.8.1.

5.9 Anti-bump granules of pumice stone

washed in hydrochloric acid and calcined

5.10 Sodium nitrate

p. a.

6 Apparatus

6.1 Distillation apparatus

Consisting of a round-bottomed flask of suitable capacity connected to a condenser by means of a splash head. The equipment is made of borosilicate glass.

NOTE The different types of equipment recommended for this determination are reproduced, showing all the features of construction, in Figures 1, 2, 3 and 4.

An automatic distillation apparatus may also be used, provided that the results are statistically equivalent.

iTeh STANDARD PREVIEW
(standards.iteh.ai)

[SIST-TS CEN/TS 15558:2008](https://standards.iteh.ai/catalog/standards/sist/cc9b143e-5181-4438-98e1-9f30316b3865/sist-ts-cen-ts-15558-2008)
<https://standards.iteh.ai/catalog/standards/sist/cc9b143e-5181-4438-98e1-9f30316b3865/sist-ts-cen-ts-15558-2008>

Dimensions in millimetres

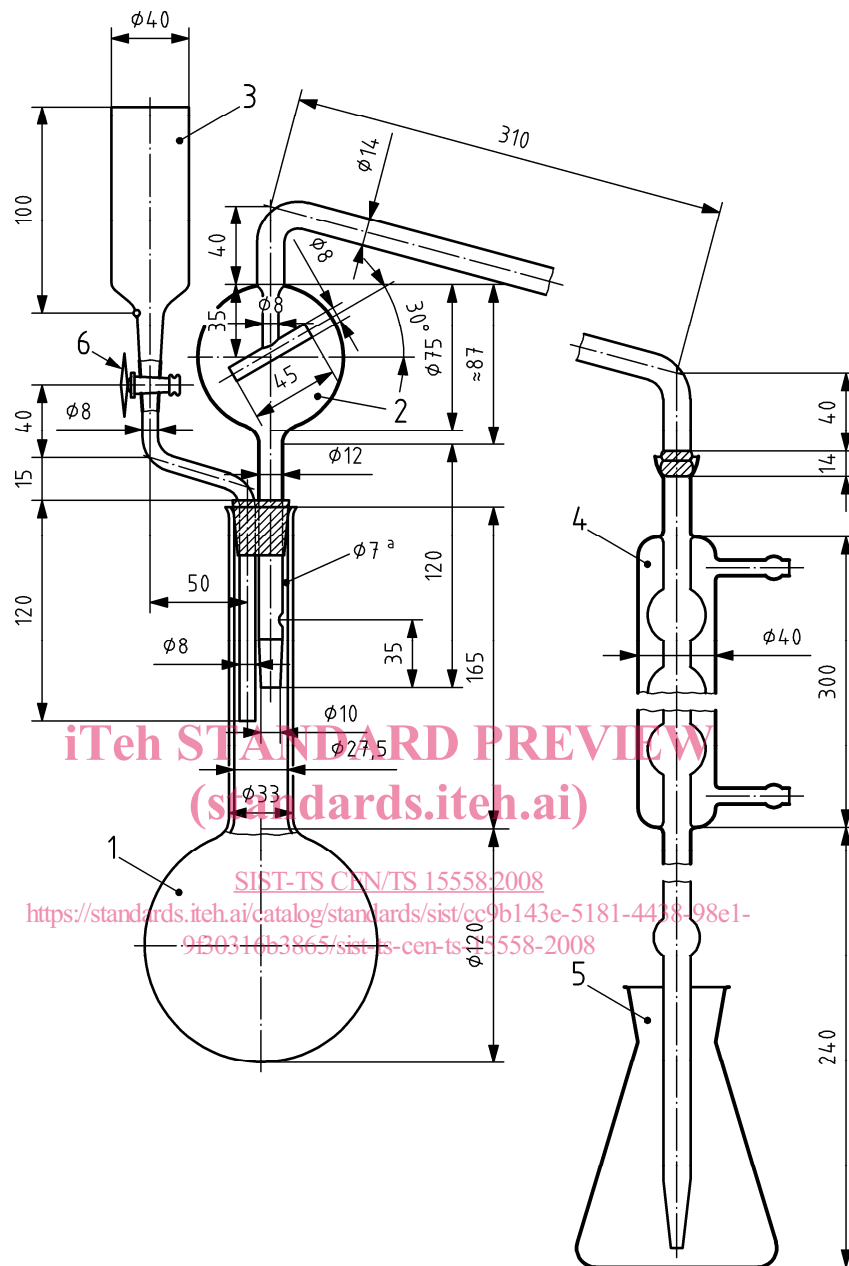

Key

- 1 round-bottomed, long-necked flask of 1 000 ml capacity
 - 2 distillation tube with a splash head, connected to the condenser by means of a spherical joint (No 18) (the spherical joint for the connection to the condenser may be replaced by an appropriate rubber connection)
 - 3 funnel with a polytetrafluoroethylene (PTFE) tap (6) for the addition of sodium hydroxide (the tap may likewise be replaced by a rubber connection with a clip)
 - 4 six-bulb condenser with spherical joint (No 18) at the entrance and joined at the issue to a glass extension tube by means of a small rubber connection (when the connection to the distillation tube is effected by means of a rubber tube, the spherical joint may be replaced by a suitable rubber bung)
 - 5 500 ml flask in which the distillate is collected
 - 6 PTFE-tap
- ^a hole

Figure 1 — Distillation apparatus 1