



SLOVENSKI STANDARD

SIST EN 1434-2:2007

01-maj-2007

BUXca Yý U

SIST EN 1434-2:1997

SIST EN 1434-2:1997/A1:2002

Toplotni števci - 2. del: Konstruktivske zahteve

Heat meters - Part 2: Constructional requirements

Wärmezähler - Teil 2: Anforderungen an die Konstruktion

Compteurs d'énergie thermique - Partie 2: Prescriptions de fabrication

Ta slovenski standard je istoveten z: **EN 1434-2:2007**

ICS:

17.200.10 Toplota. Kalorimetrija Heat. Calorimetry

SIST EN 1434-2:2007

en

iTeh STANDARD PREVIEW
(standards.iteh.ai)

SIST EN 1434-2:2007

<https://standards.iteh.ai/catalog/standards/sist/e687947e-a85d-40a6-9499-ad3bba299c40/sist-en-1434-2-2007>

English Version

Heat meters - Part 2: Constructional requirements

Compteurs d'énergie thermique - Partie 2: Prescriptions de fabrication

Wärmezähler - Teil 2: Anforderungen an die Konstruktion

This European Standard was approved by CEN on 7 January 2007.

CEN members are bound to comply with the CEN/CENELEC Internal Regulations which stipulate the conditions for giving this European Standard the status of a national standard without any alteration. Up-to-date lists and bibliographical references concerning such national standards may be obtained on application to the CEN Management Centre or to any CEN member.

This European Standard exists in three official versions (English, French, German). A version in any other language made by translation under the responsibility of a CEN member into its own language and notified to the CEN Management Centre has the same status as the official versions.

CEN members are the national standards bodies of Austria, Belgium, Bulgaria, Cyprus, Czech Republic, Denmark, Estonia, Finland, France, Germany, Greece, Hungary, Iceland, Ireland, Italy, Latvia, Lithuania, Luxembourg, Malta, Netherlands, Norway, Poland, Portugal, Romania, Slovakia, Slovenia, Spain, Sweden, Switzerland and United Kingdom.

ITIH STANDARD PREVIEW
(standards.iteh.ai)

SIST EN 1434-2:2007
<https://standards.iteh.ai/catalog/standards/sist/e687947e-a85d-40a6-9499-ad3bba299c40/sist-en-1434-2-2007>



EUROPEAN COMMITTEE FOR STANDARDIZATION
COMITÉ EUROPÉEN DE NORMALISATION
EUROPÄISCHES KOMITEE FÜR NORMUNG

Management Centre: rue de Stassart, 36 B-1050 Brussels

Contents

Page

Foreword.....	4
1 Scope	5
2 Normative references	5
3 Temperature sensors	5
3.1 General.....	5
3.2 Mechanical design	6
3.2.1 General.....	6
3.2.2 Materials of temperature probe sheath and pocket	6
3.2.3 Dimensions of direct mounted short probes - Type DS	6
3.2.4 Dimensions of direct mounted long probes - Type DL.....	6
3.2.5 Dimensions of pocket mounted long probes - Type PL	9
3.2.6 Dimensions of temperature pocket.....	9
3.2.7 Design of short probes with respect to installation	11
3.2.8 Design of long probes with respect to installation	11
3.3 Platinum temperature sensor.....	12
3.3.1 Specialised definitions for 2 wire temperature probes.....	12
3.3.2 Resistance characteristics	13
3.3.3 Signal leads	14
3.3.4 Temperature sensors for the 2-wire method	14
3.3.5 Temperature sensors for the 4-wire method	14
3.3.6 Thermal response time	15
3.4 Other temperature sensors.....	15
4 Flow sensors	15
4.1 Maximum admissible working pressure, PS in bar	15
4.2 Sizes and dimensions	15
4.3 Test signal output.....	17
4.4 Adjusting device	17
5 Calculators	17
5.1 Mechanical dimensions for calculators for domestic use.....	17
5.2 Terminals - specification and identification.....	18
5.2.1 General.....	18
5.2.2 Terminals for signal leads	18
5.2.3 Terminals for connection to the mains supply.....	19
5.3 Batteries.....	20
5.4 Dynamic behaviour.....	20
5.5 Test signal output.....	20
5.6 24 h interruption in supply voltage	20
6 Complete meter.....	20
7 Interfaces between sub-assemblies	20
7.1 Definitions for pulse device interfaces.....	21
7.1.1 General.....	21
7.1.2 Electrical connection.....	21
7.1.3 Classification of pulse output devices	21
7.1.4 Timing and electrical parameters for pulse output devices (other than test signals).....	22
7.1.5 Classification of pulse input devices	22
7.1.6 Timing and electrical parameter for pulse input devices	23
7.1.7 Compatibility	23
8 Marking and security seals	24

8.1	Marking	24
8.1.1	General	24
8.1.2	Temperature sensor pairs	24
8.1.3	Pockets	24
8.1.4	Flow sensor	24
8.1.5	Calculator	25
8.1.6	Complete meter	25
8.2	Sites for marking	26
8.3	Security seals	26
Annex A (informative) Examples of temperature sensors		27
Annex B (normative) Input and output test signals		36
Annex C (informative) Low voltage Power Supply for heat meters and their sub-assemblies		39
C.1	Remote supply	39
C.1.1	Voltage (DC or AC)	39
C.1.2	Current available	39
C.1.3	Cabling requirements	39
C.2	Local external DC supply	39
C.2.1	Voltage	39
C.2.2	Other data	40
C.3	Power supply specifications	40
Annex ZA (informative) Relationship between this European Standard and the Essential Requirements of EU Directive 2004/22/EC, MID		41
Bibliography		42

ITeH STANDARD PREVIEW
(standards.iteh.ai)

SIST EN 1434-2:2007

<https://standards.iteh.ai/catalog/standards/sist/e687947e-a85d-40a6-9499-ad3bba299c40/sist-en-1434-2-2007>

Foreword

This document (EN 1434-2:2007) has been prepared by Technical Committee CEN/TC 176 "Heat meters", the secretariat of which is held by DS.

This European Standard shall be given the status of a national standard, either by publication of an identical text or by endorsement, at the latest by August 2007, and conflicting national standards shall be withdrawn at the latest by August 2007.

This document supersedes EN 1434-2:1997.

The other parts are

Part 1 - General requirements

Part 3 - Data exchange and interfaces

Part 4 - Pattern approval tests

Part 5 - Initial verification tests

Part 6 - Installation, commissioning, operational monitoring and maintenance

According to the CEN/CENELEC Internal Regulations, the national standards organizations of the following countries are bound to implement this European Standard: Austria, Belgium, Bulgaria, Cyprus, Czech Republic, Denmark, Estonia, Finland, France, Germany, Greece, Hungary, Iceland, Ireland, Italy, Latvia, Lithuania, Luxembourg, Malta, Netherlands, Norway, Poland, Portugal, Romania, Slovakia, Slovenia, Spain, Sweden, Switzerland and United Kingdom.

iTeh STANDARD PREVIEW
(standards.iteh.ai)

SIST EN 1434-2:2007
<https://standards.iteh.org/catalog/standards/sist/c687947c-285d-40a6-b499-ad3bba299c40/sist-en-1434-2-2007>

1 Scope

This European Standard specifies the constructional requirements and applies to heat meters, that is to instruments intended for measuring the heat which, in a heat-exchange circuit, is absorbed (cooling) or given up (heating) by a liquid called the heat-conveying liquid. The heat meter indicates the quantity of heat in legal units.

Electrical safety requirements are not covered by this European Standard.

Pressure safety requirements are not covered by this European Standard.

Surface mounted temperature sensors are not covered by this European Standard.

2 Normative references

The following referenced documents are indispensable for the application of this document. For dated references, only the edition cited applies. For undated references, the latest edition of the referenced document (including any amendments) applies.

EN 1434-1:2007, *Heat meters — Part 1: General requirements*

prEN 1434-3, *Heat meters — Part 3: Data exchange and interfaces*

EN 60751:1995, *Industrial platinum resistance thermometer sensors (IEC 60751:1983 + A1:1986)*

EN 60947-5-6, *Low-voltage switchgear and controlgear — Part 5-6: Control circuit devices and switching elements — DC interface for proximity sensors and switching amplifiers (NAMUR) (IEC 60947-5- 6:1999)*

EN ISO 228-1, *Pipe threads where pressure tight joints are not made on the threads — Part 1: Dimensions, tolerances and designation (ISO 228-1:2000)*

ISO 4903, *Information technology — Data communication — 15-pole DTE/DCE interface connector and contact number assignments*

ISO 7005-1, *Metallic flanges — Part 1: Steel flanges*

ISO 7005-2, *Metallic flanges — Part 2: Cast iron flanges*

ISO 7005-3, *Metallic flanges — Part 3: Copper alloy and composite flanges*

3 Temperature sensors

3.1 General

The temperature sensor sub-assembly shall consist of platinum resistance temperature sensors selected as matched pairs.

Other types of temperature sensor pairs may be used, where the sub-assembly consists, inseparably, of temperature sensors and calculator.

The maximum admissible working pressure shall be declared by the supplier.

Where no dimensional tolerance is specified, the values shall be taken from Table 1.

Table 1 — Tolerances

Dimension mm	0,5 up to 3	over 3 up to 6	over 6 up to 30	over 30 up to 120	over 120 up to 400
Tolerance mm	± 0,2	± 0,3	± 1	± 1,5	± 2,5

3.2 Mechanical design

3.2.1 General

For pipe sizes up to and including DN 250, 3 different temperature sensor types are standardised:

direct mounted short probes - Type DS;

direct mounted long probes - Type DL;

pocket mounted long probes - Type PL.

Types PL and DL can be either head probes or have permanently connected signal leads. Type DS shall have permanently connected signal leads only.

STANDARD PREVIEW
(standards.iteh.ai)

3.2.2 Materials of temperature probe sheath and pocket

The temperature pocket and the protective sheath of direct mounted probes shall be of a material, that is adequately strong and resistant to corrosion and has the requisite thermal conductivity.

A suitable material has been shown to be EN 10088-3 - X6 Cr Ni Mo Ti 17 12 2

3.2.3 Dimensions of direct mounted short probes - Type DS

The dimensions shall be as given in Figure 1.

Further non-normative information is given in Annex A, Figure A.1.

The qualifying immersion depth shall be 20 mm – or less if so specified by the supplier.

3.2.4 Dimensions of direct mounted long probes - Type DL

The dimensions shall be as given in Figure 2.

Further information is given in Annex A, Figures A.2 and A.3.

The qualifying immersion depth shall be 50 % of the length B – or less if so specified by the supplier.

Dimensions in millimetres

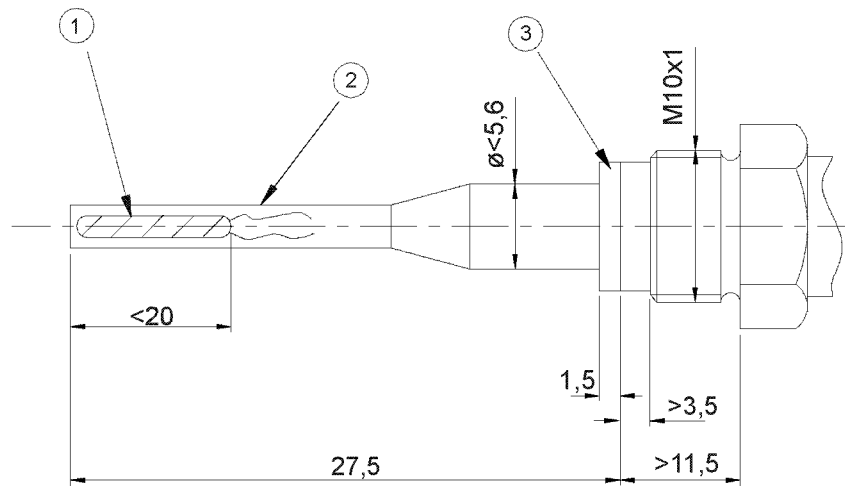
**Key**

- 1 temperature sensing element
- 2 protective sheath
- 3 sealing ring

iTeh STANDARD PREVIEW
(standards.iteh.ai)

Figure 1 — Temperature probes type DS

SIST EN 1434-2:2007

<https://standards.iteh.ai/catalog/standards/sist/e687947e-a85d-40a6-9499-ad3bba299c40/sist-en-1434-2-2007>

Dimensions in millimetres

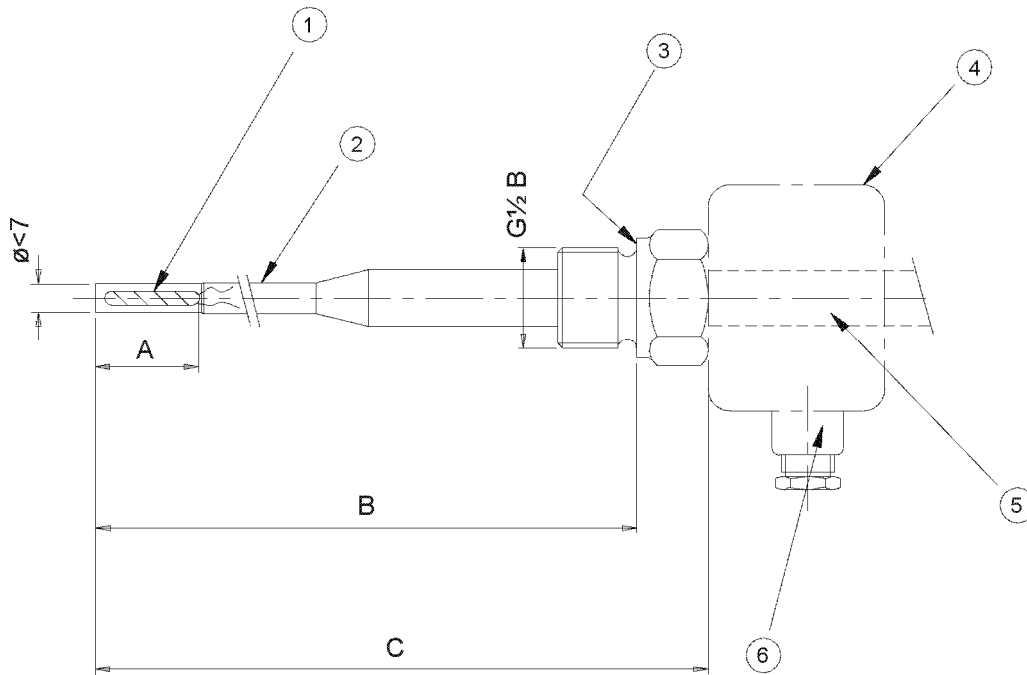

iTeh STANDARD PREVIEW
(standards.iteh.ai)

Key

G 1/2 B thread in accordance with EN ISO 228-1

[SIST EN 1434-2:2007](#)

A: < 30 mm or ≤ 50 mm for [PT1000 standards.iteh.ai/catalog/standards/sist/e687947e-a85d-40a6-9499-ad3bba299c40/sist-en-1434-2-2007](#)

Alternative lengths	
B	C head probe only
85	105
120	140
210	230

- 1 temperature sensing element
- 2 protective sheath
- 3 sealing face
- 4 outline of head probe
- 5 outline of permanently connected signal lead probe
- 6 inlet for signal cable – $\varnothing \leq 9$ mm

Figure 2 — Temperature probes type DL (head or cable)

3.2.5 Dimensions of pocket mounted long probes - Type PL

The dimensions shall be as given in Figure 3.

Further information is given in Annex A, Figures A.4 and A.5.

The qualifying immersion depth shall be 50 % of the length B for the shortest pocket specified – or less if so specified by the supplier.

3.2.6 Dimensions of temperature pocket

The temperature pocket is designed for use with type PL temperature probes only. It is designed to be capable of being inserted through a pipe wall to which has been externally brazed or welded a boss (see Annex A, Figure A.6 a) and b) and in this respect only, it is interchangeable with a direct mounted long probe of corresponding insertion length. The dimensions shall be as given in Figure 4.

iTeh STANDARD PREVIEW
(standards.iteh.ai)

[SIST EN 1434-2:2007](https://standards.iteh.ai/catalog/standards/sist/e687947e-a85d-40a6-9499-ad3bba299c40/sist-en-1434-2-2007)

<https://standards.iteh.ai/catalog/standards/sist/e687947e-a85d-40a6-9499-ad3bba299c40/sist-en-1434-2-2007>

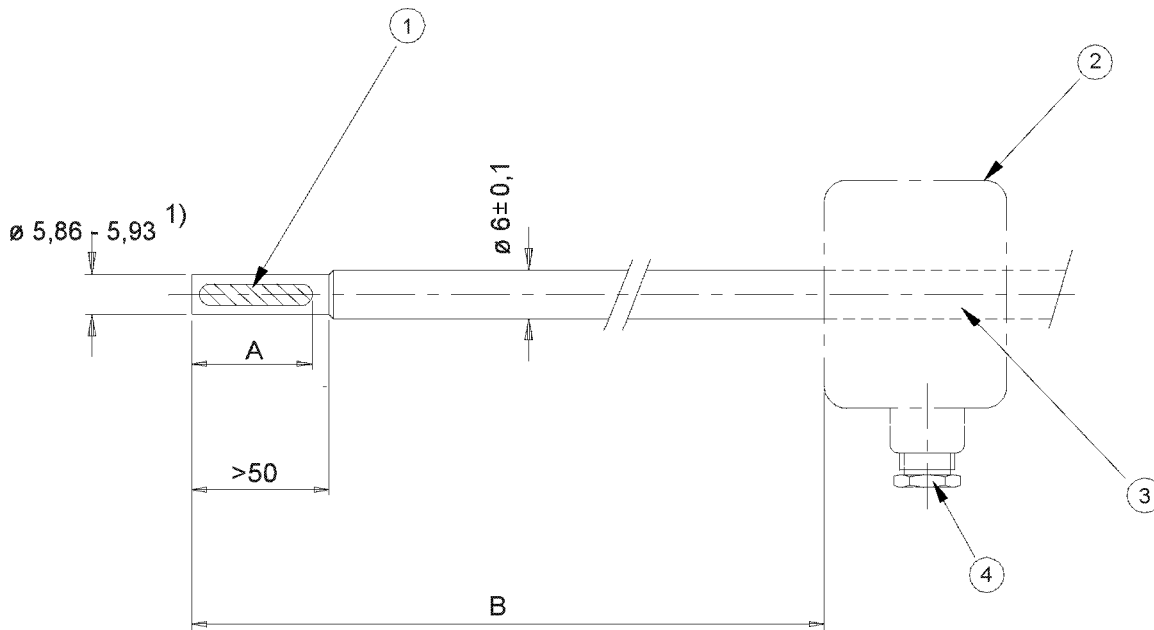

Key

1) Corresponding to c11 in ISO 286-2, rounded to 2 decimals

A: < 30 mm or ≤ 50 mm for PT1000

SIST EN 1434-2:2007
<https://standards.iteh.ai/catalog/standards/sist/e687947e-a85d-40a6-9499-ad3bba299c40/sist-en-1434-2-2007>

Alternative lengths
B (head probe only)
105
140
230

- 1 temperature sensing element
- 2 outline of head probe
- 3 outline of permanently connected signal lead probe
- 4 inlet for signal cable – $\varnothing \leq 9$ mm

Figure 3 — temperature probes – Type PL (head or cable)

Dimensions in millimetres

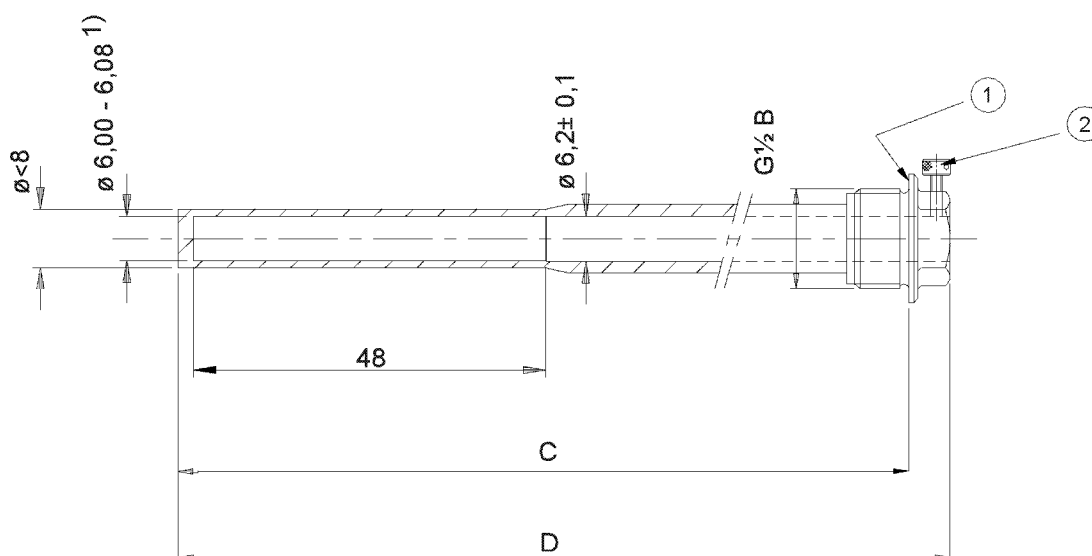
**Key**

1) Corresponding to H11 in ISO 286-2 rounded to 2 decimals

G 1/2 B thread in accordance with EN ISO 228-1

Alternative lengths	
C	D
85	≤ 100
120	≤ 135
210	≤ 225

1 sealing face

2 probe clamping screw with provision for security sealing

Figure 4 — Temperature pocket

3.2.7 Design of short probes with respect to installation

The sensor shall be mounted perpendicular to the flow and with the sensing element inserted to at least the centre of the pipe.

For internal pressures up to 16 bar, the sensor shall be designed to fit in a pipe fitting (see Annex A, Figure A.7).

3.2.8 Design of long probes with respect to installation

The sensor shall be mounted with the sensing element inserted to at least the centre of the pipe.