Kroglasti drsni zgibi - 3. del: Aksialni kroglasti drsni zgibi

Spherical plain bearings -- Part 3: Thrust spherical plain bearings

Rotules lisses -- Partie 3: Rotules lisses axiales

Ta slovenski standard je istoveten z: ISO 12240-3:1998[SIST ISO 12240-3:2001](https://standards.iteh.ai/catalog/standards/sist/9bbed2c5-0c59-4ce6-ae6e-047672acedf7/sist-iso-12240-3-2001)<https://standards.iteh.ai/catalog/standards/sist/9bbed2c5-0c59-4ce6-ae6e-047672acedf7/sist-iso-12240-3-2001>**ICS:**

21.100.10 Drsni ležaji Plain bearings

SIST ISO 12240-3:2001**en**

iTeh STANDARD PREVIEW
(standards.iteh.ai)

[SIST ISO 12240-3:2001](https://standards.iteh.ai/catalog/standards/sist/9bbed2c5-0c59-4ce6-ae6e-047672acedf7/sist-iso-12240-3-2001)

<https://standards.iteh.ai/catalog/standards/sist/9bbed2c5-0c59-4ce6-ae6e-047672acedf7/sist-iso-12240-3-2001>

INTERNATIONAL
STANDARD

ISO
12240-3

First edition
1998-08-15

**Spherical plain bearings —
Part 3:
Thrust spherical plain bearings**

Rotules lisses —

Partie 3: Rotules lisses axiales

iTeh STANDARD PREVIEW
(standards.iteh.ai)

[SIST ISO 12240-3:2001](https://standards.iteh.ai/catalog/standards/sist/9bbed2c5-0c59-4ce6-ae6e-047672acedf7/sist-iso-12240-3-2001)

<https://standards.iteh.ai/catalog/standards/sist/9bbed2c5-0c59-4ce6-ae6e-047672acedf7/sist-iso-12240-3-2001>



Reference number
ISO 12240-3:1998(E)

ISO 12240-3:1998(E)

Foreword

ISO (the International Organization for Standardization) is a worldwide federation of national standard bodies (ISO member bodies). The work of preparing International Standards is normally carried out through ISO technical committees. Each member body interested in a subject for which a technical committee has been established has the right to be represented on that committee. International organizations, governmental and non-governmental, in liaison with ISO, also take part in the work. ISO collaborates closely with the International Electrotechnical Commission (IEC) on all matters of electrotechnical standardization.

Draft International Standards adopted by the technical committees are circulated to the member bodies for voting. Publication as an International Standard requires approval by at least 75 % of the member bodies casting a vote.

International Standard ISO 12240-3 was prepared by Technical Committee ISO/TC 4, *Rolling bearings*, Subcommittee SC 7, *Spherical plain bearings*.

ISO 12240 consists of the following parts, under the general title *Spherical plain bearings*:

- *Part 1: Radial spherical plain bearings*
- *Part 2: Angular contact radial spherical plain bearings*
- *Part 3: Thrust spherical plain bearings*
- *Part 4: Spherical plain bearing rod ends*

© ISO 1998

All rights reserved. Unless otherwise specified, no part of this publication may be reproduced or utilized in any form or by any means, electronic or mechanical, including photocopying and microfilm, without permission in writing from the publisher.

International Organization for Standardization
Case postale 56 • CH-1211 Genève 20 • Switzerland
Internet iso@iso.ch

Printed in Switzerland

Spherical plain bearings —

Part 3: Thrust spherical plain bearings

1 Scope

This part of ISO 12240 specifies dimensions and tolerances for thrust spherical plain bearings.

The specified tolerance values apply to finished, thrust spherical plain bearings before any coating or plating.

Thrust spherical plain bearings need not conform to the design illustrated but compliance is required as regards dimensions and tolerances specified.

NOTE — Thrust spherical plain bearings for airframe applications are not covered by this part of ISO 12240.

2 Normative references

The following standards contain provisions which, through reference in this text, constitute provisions of this part of ISO 12240. At the time of publication, the editions indicated were valid. All standards are subject to revision, and parties to agreements based on this part of ISO 12240 are encouraged to investigate the possibility of applying the most recent editions of the standards indicated below. Members of IEC and ISO maintain registers of currently valid International Standards.

ISO 582 : 1995, *Rolling bearings – Chamfer dimensions – Maximum values.*

ISO 1132-1: —¹⁾, *Rolling bearings – Tolerances – Part 1: Terms and definitions.*

ISO 6811:1998, *Spherical plain bearings – Vocabulary.*

3 Definitions and symbols

For the purposes of this part of ISO 12240, the definitions given in ISO 1132-1 and ISO 6811 apply. The symbols (except those for tolerances) shown in figure 1 and the values given in the tables denote nominal dimensions unless specified otherwise.

<i>B</i>	Shaft washer height
<i>C</i>	Housing washer height
<i>D</i>	Outside diameter
<i>D</i> ₁	Bore diameter of housing washer
<i>d</i>	Bore diameter

1) To be published. (Revision of ISO 1132:1980)

d_1	Outside diameter of shaft washer
d_2	Diameter of plain back face of shaft washer
d_k	Sphere diameter
$r_{s \min 2)}$	Smallest single chamfer dimension, inner ring
$r_{1s \min 2)}$	Smallest single chamfer dimension, outer ring
s	Distance between sphere diameter centre and shaft washer back face
T	Bearing height
V_{Dmp}	Variation of mean outside diameter
V_{dmp}	Variation of mean bore diameter
V_{Dp}	Variation of outside diameter in a single radial plane
V_{dp}	Variation of bore diameter in a single radial plane
Δ_{Bs}	Deviation of a single shaft washer height
Δ_{Cs}	Deviation of a single housing washer height
Δ_{Dmp}	Deviation of mean outside diameter in a single plane
Δ_{dmp}	Deviation of mean bore diameter in a single plane
Δ_{Ts}	Deviation of the actual bearing height

iTech STANDARD PREVIEW
(standards.iteh.ai)

4 Dimensions and tolerances

SIST ISO 12240-3:2001

4.1 Dimensions

<https://standards.iteh.ai/catalog/standards/sist/9bbed2c5-0c59-4ce6-ae6e-047672acedf7/sist-iso-12240-3-2001>

See figure 1 and table 1.

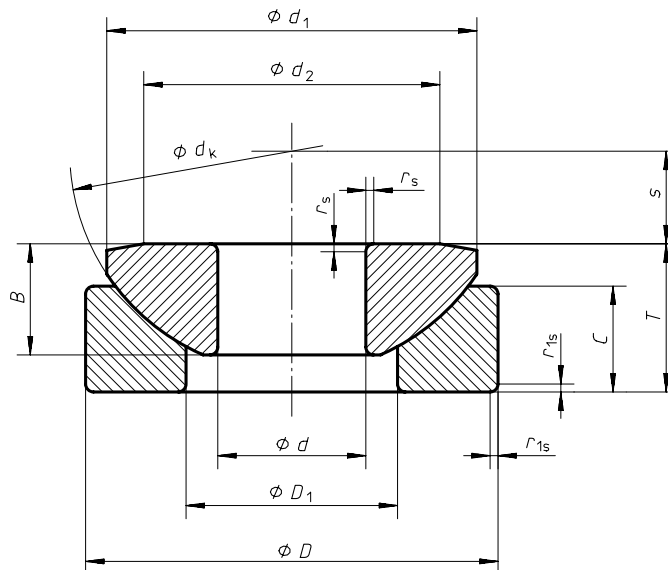

Figure 1 — Thrust spherical plain bearing

2) The corresponding maximum chamfer dimensions are given in table 5 of ISO 582:1995.

Table 1 — Dimensions for thrust spherical plain bearings

Dimensions in millimetres

d	D	B max.	C max.	T	d_k ¹⁾	s ≈	d_1 min.	d_2 ²⁾ ≈	D_1 max.	r_s, r_{1s} min.
10	30	8	7	9,5	32	7	27	21	17	0,6
12	35	10	10	13	38	8	31,5	24	20	0,6
15	42	11	11	15	46	10	38,5	29	24,5	0,6
17	47	12	12	16	51	11	43	34	28,5	0,6
20	55	15	14	20	60	12,5	49,5	40	34	1
25	62	17	17	22,5	67	14	57	45	35	1
30	75	19	20	26	81	17,5	68,5	56	44,5	1
35	90	22	21	28	98	22	83,5	66	52,5	1
40	105	27	22	32	114	24,5	96	78	59,5	1
45	120	31	26	36,5	129	27,5	109	89	68,5	1
50	130	34	32	42,5	140	30	119	98	71	1
60	150	37	34	45	160	35	139	109	86,5	1
70	160	42	37	50	173	35	149	121	95,5	1
80	180	44	38	50	196	42,5	167	135	109	1
100	210	51	46	59	221	45	194	155	134	1
120	230	54	50	64	248	52,5	213	170	155	1
140	260	61	54	72	274	52,5	243	198	177	1,5
160	290	66	58	77	313	65	271	213	200	1,5
180	320	74	62	86	340	67,5	299	240	225	1,5
200	340	80	66	87	365	70	320	265	247	1,5

1) Reference only.
2) At manufacturer's discretion.

4.2 Tolerances

See tables 2 and 3.

Table 2 — Tolerances for shaft washer and bearing height

d mm		Δ_{dmp} μm		V_{dp} μm max.	V_{dmp} μm max.	Δ_{Bs} μm		Δ_{Ts} μm	
over	including	high	low			high	low	high	low
2,5	18	0	- 8	8	6	0	- 240	+250	- 400
18	30	0	- 10	10	8	0	- 240	+250	- 400
30	50	0	- 12	12	9	0	- 240	+250	- 400
50	80	0	- 15	15	11	0	- 300	+250	- 500
80	120	0	- 20	20	15	0	- 400	+250	- 600
120	180	0	- 25	25	19	0	- 500	+350	- 700
180	200	0	- 30	30	23	0	- 600	+350	- 800

Table 3 — Tolerances for housing washer

D mm		Δ_{Dmp} μm		V_{Dp} μm max.	V_{Dmp} μm max.	Δ_{Cs} μm	
over	including	high	low			high	low
18	30	0	- 9	12	7	0	- 240
30	50	0	- 11	15	8	0	- 240
50	80	0	- 13	17	10	0	- 300
80	120	0	- 15	20	11	0	- 400
120	150	0	- 18	24	14	0	- 500
150	180	0	- 25	33	19	0	- 500
180	250	0	- 30	40	23	0	- 600
250	315	0	- 35	47	26	0	- 700
315	400	0	- 40	53	30	0	- 800