



SLOVENSKI STANDARD
oSIST-TS prCEN/TS 1992-4-1:2008
01-september-2008

Projektiranje pritrjevanja za uporabo v betonu - 4-1: Splošno

Design of fastenings for use in concrete - Part 4-1: General

Bemessung von Befestigungen in Beton - Teil 4-1: Allgemeines

Ta slovenski standard je istoveten z: prCEN/TS 1992-4-1

ICS:

21.060.01	Vezni elementi na splošno	Fasteners in general
91.080.40	Betonske konstrukcije	Concrete structures

oSIST-TS prCEN/TS 1992-4-1:2008 **en**

iTeh STANDARD PREVIEW
(standards.iteh.ai)

Full standard:
<https://standards.iteh.ai/catalog/standards/sist/67cddf05-e364-4494-b65b-0d6c7880639a/sist-ts-cen-ts-1992-4-1-2009>

TECHNICAL SPECIFICATION
SPÉCIFICATION TECHNIQUE
TECHNISCHE SPEZIFIKATION

FINAL DRAFT
prCEN/TS 1992-4-1

June 2008

ICS 21.060.01; 91.080.40

English Version

Design of fastenings for use in concrete - Part 4-1: General

Bemessung von Befestigungen in Beton - Teil 4-1:
Allgemeines

This draft Technical Specification is submitted to CEN members for formal vote. It has been drawn up by the Technical Committee CEN/TC 250.

CEN members are the national standards bodies of Austria, Belgium, Bulgaria, Cyprus, Czech Republic, Denmark, Estonia, Finland, France, Germany, Greece, Hungary, Iceland, Ireland, Italy, Latvia, Lithuania, Luxembourg, Malta, Netherlands, Norway, Poland, Portugal, Romania, Slovakia, Slovenia, Spain, Sweden, Switzerland and United Kingdom.

Warning : This document is not a Technical Specification. It is distributed for review and comments. It is subject to change without notice and shall not be referred to as a Technical Specification.

PRELIMINARY DRAFT
Technical Standard
(standards.international)
Full standard:
<https://standards.iteh.ai/catalog/standards/sist-ts-1992-4-1-2009>
4494-b65b-016c7880639a/sist-ts-1992-4-1-2009



EUROPEAN COMMITTEE FOR STANDARDIZATION
COMITÉ EUROPÉEN DE NORMALISATION
EUROPÄISCHES KOMITEE FÜR NORMUNG

Management Centre: rue de Stassart, 36 B-1050 Brussels

Contents

	Page
Foreword.....	4
1 Scope	5
1.1 General.....	5
1.2 Type of fasteners and fastening groups	5
1.3 Fastener dimensions and materials.....	7
1.4 Fastener loading	7
1.4.1 Type of loading	7
1.4.2 Direction of loading	8
1.5 Concrete strength	8
1.6 Concrete member loading	8
2 Normative references	9
3 Definitions and symbols	10
3.1 Definitions	10
3.2 Notations	15
3.2.1 Indices.....	15
3.2.2 Actions and Resistances	16
3.2.3 Concrete and steel.....	17
3.2.4 Units	19
4 Basis of design	20
4.1 General.....	20
4.2 Required verifications	20
4.3 Design format.....	21
4.4 Verification by the partial factor method.....	22
4.4.1 General.....	22
4.4.2 Partial factors for indirect and fatigue actions	22
4.4.3 Partial factors for resistance	22
4.5 Project specification and installation of fasteners.....	24
5 Determination of concrete condition and action effects	25
5.1 Non-cracked and cracked concrete	25
5.2 Derivation of forces acting on fasteners	25
5.2.1 General.....	25
5.2.2 Tension loads.....	26
5.2.3 Shear loads.....	29
6 Verification of ultimate limit state	36
6.1 General.....	36
7 Verification of fatigue limit state	37
7.1 General.....	37
7.2 Derivation of loads acting on fasteners	38
7.3 Resistance	39
8 Verification for seismic loading	41
8.1 General.....	41
8.2 Requirements	41
8.3 Actions.....	41
8.4 Resistance	41
9 Verification of serviceability limit state	44
Annex A (normative)	45
A.1 Local transmission of fastener loads into the concrete member.....	45
A.1.1 General.....	45
A.1.2 Verification of the shear resistance of the concrete member.....	45
A.1.3 Verification of the resistance to splitting forces	46

Annex B (normative).....	47
B.1 Plastic design approach, fastenings with headed fasteners and post-installed fasteners.....	47
B.1.1 Field of application.....	47
B.1.2 Loads on fastenings.....	49
B.1.3 Design of fastenings	51
Annex C (informative).....	54
C.1 Durability	54
C.1.1 General	54
C.1.2 Fasteners in dry, internal conditions	54
C.1.3 Fasteners in external atmospheric or in permanently damp internal exposure.....	54
C.1.4 Fasteners in high corrosion exposure by chloride and sulphur dioxide	54
Annex D (informative).....	55
D.1 Exposure to fire – design method	55
D.1.1 General	55
D.1.2 Partial factors.....	55
D.1.3 Resistance under fire exposure.....	55
Annex E (informative).....	59
E.1 Recommended additions and alterations to EN 1998-1:2004, 4.3.5 (Design of structures for earthquake resistance) for the design of fastenings under seismic loading.....	59
E.1.1 General	59
E.1.2 Additions to Section 4.3.5.1 of EN 1998-1:2004.....	59
E.1.3 Additions and alterations to EN 1998-1:2004, 4.3.5.2	59
E.1.4 Additions to EN 1998-1:2004, 4.3.5.3	61
E.1.5 Additions and alterations to EN 1998-1:2004, 4.3.5.4	61

iTeh STANDARD PREVIEW
 (standards.iteh.ai)
 Full standard:
<https://standards.iteh.ai/catalog/standards/sist/61c40d15-384-4494-b65b-016c7880639a/sist-ts-cen-ts-1992-4-1-2008>

prCEN/TS 1992-4-1:2008 (E)**Foreword**

This document (prCEN/TS 1992-4-1:2008) has been prepared by Technical Committee CEN/TC 250 “Structural Eurocodes”, the secretariat of which is held by BSI.

This document is currently submitted to the Formal Vote.

This Technical Specification CEN/TS 1992-4-1 — General, describes the general principles and requirements for safety, serviceability and durability of fasteners for use in concrete, together with specific requirements for structures serving as base material for the fasteners. It is based on the limit state concept used in conjunction with a partial factor method.

The numerical values for partial factors and other reliability parameters are recommended values and may be changed in a National Annex, if required. The recommended values apply when

- a) The fasteners comply with the requirements of 1.2.2, and
- b) The installation complies with the requirements of 4.5.

National Annex for CEN/TS 1992-4-1

This CEN/TS gives values with notes indicating where national choices may have to be made. When this CEN/TS is made available at national level it may be followed by a National Annex containing all Nationally Determined Parameters to be used for the design of fastenings according to this CEN/TS for use in the relevant country.

National choice of the partial factors and reliability parameters is allowed in design according to this CEN/TS in the following clauses:

- 4.4.2;
- 4.4.3.1.1;
- 4.4.3.1.2;
- 4.4.3.1.3;
- 4.4.3.2;
- 4.4.3.3;
- 5.1.2;
- B.1.3.1;
- D.1.2.

CEN/TS 1992-4 'Design of fastenings for use in concrete' is subdivided into the following parts:

- *Part 1: General*
- *Part 2: Headed fasteners*
- *Part 3: Anchor channels*
- *Part 4: Post-installed fasteners — mechanical systems*
- *Part 5: Post-installed fasteners — chemical systems*

Part 1 is applicable to all products. Special rules applicable to particular products are given in Parts 2 to 5 of the series CEN/TS EN 1992-4. These Parts should be used only in conjunction with Part 1.

1 Scope

1.1 General

1.1.1 This CEN/TS provides a design method for fasteners for structural purpose, which are used to transmit actions to the concrete.

Inserts embedded in precast concrete elements during production, under FPC conditions and with the due reinforcement, intended for use only during transient situations for lifting and handling, are covered by the CEN/TR "Design and Use of Inserts for Lifting and Handling Precast Concrete Elements", by CEN TC 229.

1.1.2 This CEN/TS is intended for applications in which the failure of fastenings will:

- 1) result in collapse or partial collapse of the structure, or
- 2) cause risk to human life, or
- 3) lead to significant economic loss.

1.1.3 The support of the fixture may be either statically determinate or statically indeterminate, defined as multiple anchor use in some European Technical Approvals (ETAs). Each support may consist of one fastener or a group of fasteners.

1.1.4 This CEN/TS is valid for applications which fall within the scope of the series EN 1992. In applications where special considerations apply, e.g. nuclear power plants or civil defence structures, modifications may be necessary.

1.1.5 This CEN/TS does not cover the design of the fixture. The design of the fixture shall be carried out to comply with the appropriate Standards. Requirements for stiffness and ductility of the fixture are given in clauses 5 and 8.

1.2 Type of fasteners and fastening groups

1.2.1 This CEN/TS applies to

- a) cast-in fasteners such as headed fasteners, anchor channels with rigid connection between fastener and channel;
- b) post-installed anchors such as expansion anchors, undercut anchors, concrete screws, bonded anchors, bonded expansion anchors and bonded undercut anchors.

For other types of fasteners modifications of the design provisions may be necessary.

1.2.2 This CEN/TS applies to fasteners with established suitability for the specified application in concrete covered by provisions, which refer to this CEN/TS and provide data required by this CEN/TS. The necessary data are listed in Parts 2 to 5.

NOTE Where there is no European Standard for a particular fastener which refers specifically to the use of this fastener or where the fastener deviates significantly from the European Standard, the establishment of suitability may result from:

- European Technical Approval (ETA) which refers specifically to the use of the fastener in concrete;
- relevant national standard or provision which refers specifically to the use of the fastener in concrete;
- documentation of the fastener should include the characteristic resistance of the fastener and consider effects influencing the reliability of fasteners both during installation and in service life under sustained and variable loads, as well as the sensitivity to possible deviations on any of the factors of importance.

prCEN/TS 1992-4-1:2008 (E)

- Factors to be addressed are:
 - Installation conditions in concrete on site.
 - Drilling method and drill bit diameter in case of post-installed fasteners.
 - Bore hole cleaning.
 - Installation tools.
 - Sustained (long term) and variable loads on the fastener.
 - Variable loads on the concrete structure (crack cycling).
 - Crack width in the concrete structure.
 - Environmental conditions such as air pollution, alkalinity, aggressive environment, humidity, concrete-installation temperature, service temperature...
 - Location of fasteners in the concrete component.
 - Minimum dimensions of the structural component.

In addition to the assumptions of EN 1992-1-1 it is assumed that both the design and execution of fastening systems in concrete structures is carried out by personnel having the appropriate skill and experience.

1.2.3 This CEN/TS applies to single fasteners and groups of fasteners. In a fastening group the loads are applied to the individual fasteners of the group by means of a common fixture. In this CEN/TS it is assumed that in a fastening group only fasteners of the same type and size are used.

The configurations of fasteners (cast-in place headed fasteners and post-installed fasteners) covered by this CEN/TS are shown in Figure 1.

Distinction is to be made between fastenings with and without hole clearance.

The following applications may be considered to have no hole clearance:

- a) bolts are welded to the fixture or screwed into the fixture, or
- b) any gap between the fastener and the fixture is filled with mortar of sufficient compression strength or eliminated by other suitable means;

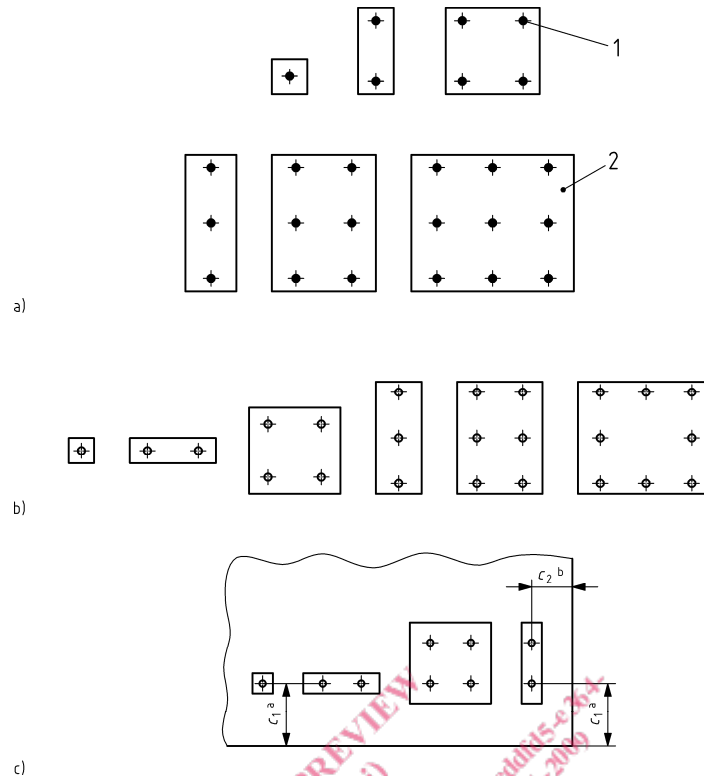

Key

- 1 Fastener
- 2 Steel plate

- a) Fastenings without hole clearance, all edge distances
- b) Fastenings with hole clearance situated far from edges
- c) Fastenings with hole clearance situated near to an edge

- a $c_1 < 10 h_{ef}$ or $c_1 < 60 d_{nom}$
- b $c_2 < 10 h_{ef}$ or $c_2 < 60 d_{nom}$

Figure 1 — Configuration of fastenings with headed and post-installed fasteners

For anchor channels the number of fasteners is not limited.

1.3 Fastener dimensions and materials

1.3.1 This CEN/TS applies to fasteners with a minimum diameter or a minimum thread size of 6 mm (M6) or a corresponding cross section. In general, the minimum embedment depth should be $h_{ef} \geq 40$ mm. The actual value for a particular fastener might be taken from the relevant European Technical Specification.

1.3.2 This CEN/TS covers metal fasteners made of either carbon steel (ISO 898), stainless steel (EN 10088, ISO 3506) or malleable cast iron (ISO 5922). The surface of the steel may be coated or uncoated. The fasteners may include non-load bearing material e.g. plastic parts. This document is valid for fasteners with a nominal steel tensile strength $f_{uk} \leq 1000$ N/mm². The binding material of bonded fasteners may be made primarily of resin, cement or a combination of the two. In addition inorganic fillers may be used.

1.4 Fastener loading

1.4.1 Type of loading

Loading on the fastenings may be static, cyclic (causing fatigue failure) and seismic. The suitability of the fastener type to resist either cyclic or seismic loading is stated in the relevant European Technical Specification.

prCEN/TS 1992-4-1:2008 (E)

1.4.2 Direction of loading

The loading on the fastener resulting from the actions on the fixture (e.g. tension, shear, bending or torsion moments or any combination thereof) will generally be axial tension and/or shear. When the shear force is applied with a lever arm a bending moment on the fastener will arise. Any axial compression on the fixture should be transmitted to the concrete either without acting on the fastener or via fasteners suitable for resisting compression (Figure 2).

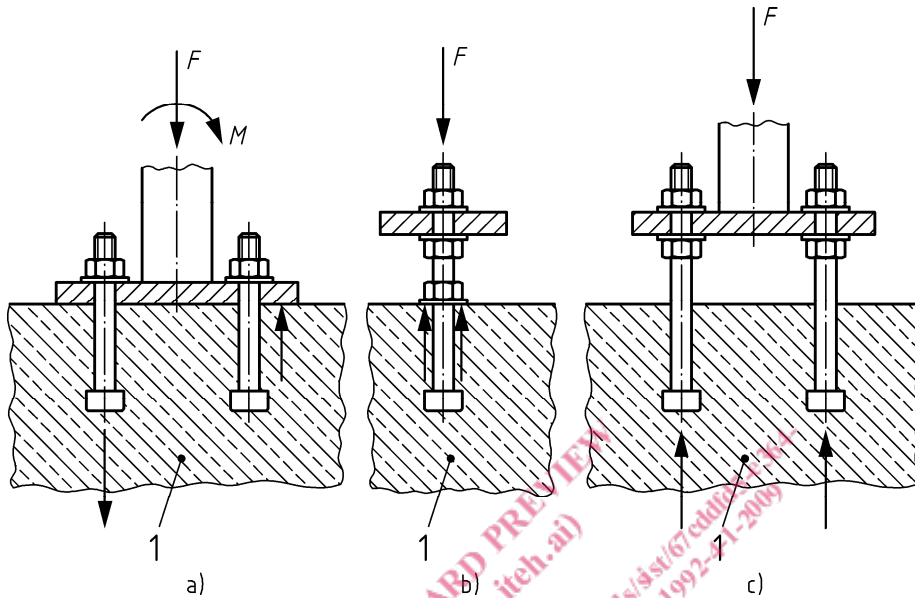

- Key**
 1 concrete
- a), b) fasteners not loaded in compression;
 in Figure (a) the compression force is transferred by the fixture and
 in Figure (b) by the washer
- c) fasteners loaded in compression

Figure 2 — Examples of fastenings loaded by a bending moment and a compression force

1.5 Concrete strength

This document is valid for members using normal weight concrete with strength classes in the range C12/15 to C90/105 all in accordance with EN 206-1. The range of concrete strength classes in which particular fasteners may be used is given in the relevant European Technical Specification and may be more restrictive than stated above.

1.6 Concrete member loading

If the concrete member is subjected to cyclic or seismic loading certain types of fasteners may not be allowed. This is stated in the corresponding European Technical Specification.

2 Normative references

This European Standard incorporates by dated or undated reference, provisions from other publications. These normative references are cited at the appropriate places in the text and the publications are listed hereafter. For dated references, subsequent amendments to or revisions of any of these publications apply to this European Standard only when incorporated in it by amendment or revision. For undated references the latest edition of the publication referred to applies.

NOTE The following references to Eurocodes are references to European Standards and European Prestandards. These are the only European documents available at the time of publication of this CEN/TS. National documents take precedence until Eurocodes are published as European Standards.

EN 1990:2002, *Eurocode — Basis of structural design*

EN 1992-1-1:2004, *Eurocode 2: Design of concrete structures — Part 1-1: General rules and rules for buildings*

EN 1993-1-1:2005, *Eurocode 3: Design of steel structures — Part 1-1: General rules and rules for buildings.*

EN 1993-1-8:2005, *Eurocode 3: Design of steel structures — Part 1-8: Design of joints.*

EN 1994-1-1:2004, *Eurocode 4: Design of composite steel and concrete structures — Part 1-1: General rules and rules for buildings.*

EN 1998-1:2004, *Eurocode 8: Design of structures for earthquake resistance — Part 1: General rules, seismic actions and rules for buildings*

EN 206-1, *Concrete — Part 1: Specification, performance, production and conformity.*

EN 10002-1, *Metallic materials — Tensile testing — Part 1: Method of test at ambient temperature.*

EN 10080, *Steel for the reinforcement of concrete — Weldable reinforcing steel — General requirements.*

EN 10088-2, *Stainless steels — Part 2: Technical delivery conditions for sheet/plate and strip of corrosion resisting sheets for general purposes.*

EN 10088-3, *Stainless steels — Part 3: Technical delivery conditions for semi-finished products, bars, rods, wire, sections and bright products of corrosion resisting sheets for general purposes.*

EN 12390-2, *Testing hardened concrete — Part 2: Making and curing specimens for strength tests.*

EN 12390-3, *Testing hardened concrete — Part 3: Compressive strength of test specimens.*

EN 12390-7, *Testing hardened concrete — Part 7: Density of hardened concrete.*

EN 12504-1, *Testing concrete in structures — Part 1: Cored specimens — Taking, examining and testing in compression.*

EN 13501-2, *Fire classification of construction products and building elements — Part 2: Classification using data from fire resistance tests, excluding ventilation services.*

EN ISO 13918, *Welding — Studs and ceramic ferrules for arc stud welding (ISO 13918:2008).*

ISO 273, *Fasteners — Clearance holes for bolts and screws.*

ISO 898-1, *Mechanical properties of fasteners made of carbon steel and alloy steel — Part 1: Bolts, screws and studs.*

prCEN/TS 1992-4-1:2008 (E)

ISO 898-2, *Mechanical properties of fasteners — Part 2: Nuts with specified proof load values — Coarse thread.*

ISO 1803:1997, *Building construction — Tolerances — Expression of dimensional accuracy — Principles and terminology.*

ISO 3506, *Mechanical properties of corrosion-resistant stainless-steel fasteners.*

ISO 5922, *Malleable cast iron (Revision of ISO 5922:1981).*

3 Definitions and symbols**3.1 Definitions****3.1.1****Anchor**

Element made of steel or malleable iron either cast into concrete or post-installed into a hardened concrete member and used to transmit applied loads (see Figures 3 to 5). In this CEN/TS 'anchor' and 'fastener' are used synonymously. In the case of anchor channels, a steel fastener is rigidly connected to the back of the channel and embedded in concrete

3.1.2**Anchor channel**

Steel profile with rigidly connected anchors (also called channel bar, see Figure 4) installed prior to concreting

3.1.3**Anchor channel loading: Axial tension**

Load applied perpendicular to the surface of the base material

3.1.4**Anchor channel loading: Bending**

Bending effect induced by a load applied perpendicular to the longitudinal axis of the channel

3.1.5**Anchor channel loading: Combined**

Axial and shear loading applied simultaneously (oblique loading)

3.1.6**Anchor channel loading: Shear**

Shear acting parallel to the concrete surface and transversely with respect to the longitudinal axis of the channel

3.1.7**Anchor group**

A number of fasteners with identical characteristics acting together to support a common attachment, where the spacing of the anchors does not exceed the characteristic spacing

3.1.8**Anchor loading: Axial**

Load applied perpendicular to the surface of the base material and parallel to the fastener longitudinal axis

3.1.9**Anchor loading: Bending**

Bending effect induced by a shear load applied with an eccentricity with respect to the centroid of resistance

3.1.10**Anchor loading: Combined**

Axial and shear loading applied simultaneously (oblique loading)

3.1.11**Anchor loading: Shear**

Shear induced by a load applied perpendicular to the longitudinal axis of the fastener

3.1.12**Anchor spacing**

Distance between the centre lines of the fasteners

3.1.13**Anchorage component**

Component (element) in which a fastener is anchored

3.1.14**Attachment**

Metal assembly that transmits loads to the fastener. In this CEN/TS 'attachment' and 'fixture' are used synonymously

3.1.15**Base material**

Material in which the fastener is installed

3.1.16**Blow-out failure**

Spalling of the concrete on the side face of the anchorage component at the level of the embedded head with no major breakout at the top concrete surface. This is usually associated with anchors with small side cover and deep embedment

3.1.17**Bonded anchor**

Fastener placed into a hole in hardened concrete, which derives its resistance from a bonding compound placed between the wall of the hole in the concrete and the embedded portion of the fastening (see Figure 3.3b))

3.1.18**Bond failure**

that occurs at the interface between the bonding compound and the base material or between the bonding compound and the metal part of a bonded anchor system

3.1.19**Bonded expansion anchor**

Bonded anchor designed such that the anchor bolt can move relative to the hardened bonding compound resulting in follow-up expansion (see Figure 5h))

3.1.20**Cast-in fastener**

Headed bolt, headed stud, hooked bolt or anchor channel installed before placing the concrete, see headed anchor

3.1.21**Characteristic spacing**

Spacing required to ensure the characteristic resistance of a single fastener