



SLOVENSKI STANDARD
oSIST-TS prCEN/TS 1992-4-3:2008
01-september-2008

Projektiranje pritrdjevanja za uporabo v betonu - 3. del: Sidrni kanali

Design of fastenings for use in concrete - Part 3: Anchor channels

Bemessung von Befestigungen in Beton - Teil 3: Ankerschienen

Ta slovenski standard je istoveten z: prCEN/TS 1992-4-3

ICS:

21.060.01	Vezni elementi na splošno	Fasteners in general
91.080.40	Betonske konstrukcije	Concrete structures

oSIST-TS prCEN/TS 1992-4-3:2008 **en**

ITeH STANDARD PREVIEW
(standards.iteh.ai)

Full standard:
<https://standards.iteh.ai/catalog/standards/sist/81f4eac5-3ea3-4c90-9e34-4e4c3ba45f33/sist-ts-cen-ts-1992-4-3-2009>

TECHNICAL SPECIFICATION
SPÉCIFICATION TECHNIQUE
TECHNISCHE SPEZIFIKATION

FINAL DRAFT
prCEN/TS 1992-4-3

June 2008

ICS 21.060.01; 91.080.40

English Version

Design of fastenings for use in concrete - Part 3: Anchor channels

Bemessung von Befestigungen in Beton - Teil 3:
Ankerschienen

This draft Technical Specification is submitted to CEN members for formal vote. It has been drawn up by the Technical Committee CEN/TC 250.

CEN members are the national standards bodies of Austria, Belgium, Bulgaria, Cyprus, Czech Republic, Denmark, Estonia, Finland, France, Germany, Greece, Hungary, Iceland, Ireland, Italy, Latvia, Lithuania, Luxembourg, Malta, Netherlands, Norway, Poland, Portugal, Romania, Slovakia, Slovenia, Spain, Sweden, Switzerland and United Kingdom.

Warning : This document is not a Technical Specification. It is distributed for review and comments. It is subject to change without notice and shall not be referred to as a Technical Specification.



EUROPEAN COMMITTEE FOR STANDARDIZATION
COMITÉ EUROPÉEN DE NORMALISATION
EUROPÄISCHES KOMITEE FÜR NORMUNG

Management Centre: rue de Stassart, 36 B-1050 Brussels

Contents	Page
Foreword.....	3
1 Scope	4
1.1 General.....	4
1.4 Anchor channel loading.....	4
1.4.3 Actions not covered	4
2 Normative references	4
3 Definitions and symbols	5
4 Basis of design	5
5 Determination of action effects	5
5.2 Derivation of forces acting on anchor channels	5
5.2.1 General.....	5
5.2.2 Tension loads.....	6
5.2.3 Shear loads.....	7
5.3 Tension forces in a supplementary reinforcement	8
5.3.3 Tension loads.....	8
5.3.4 Shear loads.....	8
6 Verification of ultimate limit state by elastic analysis	9
6.1 General.....	9
6.2 Tension loads.....	9
6.2.1 Required verifications	9
6.2.2 Design of supplementary reinforcement.....	9
6.2.3 Steel failure.....	11
6.2.4 Pullout failure	11
6.2.5 Concrete cone failure	12
6.2.6 Splitting failure.....	16
6.2.7 Blow-out failure.....	16
6.2.8 Steel failure of the supplementary reinforcement.....	18
6.2.9 Anchorage failure of the supplementary reinforcement in the concrete cone	18
6.3 Shear loads.....	19
6.3.1 Required verifications	19
6.3.2 Design of reinforcement	20
6.3.3 Steel failure.....	21
6.3.4 Concrete pry-out failure	21
6.3.5 Concrete edge failure	21
6.3.6 Steel failure of supplementary reinforcement	25
6.3.7 Anchorage failure of supplementary reinforcement in the concrete cone.....	26
6.4 Combined tension and shear loads	26
6.4.1 Anchor channels without supplementary reinforcement.....	26
6.4.2 Anchor channels with supplementary reinforcement.....	27
7 Fatigue	27
8 Seismic	27

Foreword

This document (prCEN/TS 1992-3:2008) has been prepared by Technical Committee CEN/TC 250 "Structural Eurocodes", the secretariat of which is held by BSI.

This document is currently submitted to the Formal Vote.

This Technical Specification CEN/TS 1992-4-3 — Anchor Channels, describes the principles and requirements for safety, serviceability and durability of anchor channels for use in concrete, together with specific provisions for structures serving as base material. It is based on the limit state concept used in conjunction with a partial factor method.

CEN/TS EN 1992-4 'Design of fastenings for use in concrete' is subdivided into the following parts:

- *Part 1: General*
- *Part 2: Headed fasteners*
- *Part 3: Anchor channels*
- *Part 4: Post-installed fasteners – mechanical systems*
- *Part 5: Post-installed fasteners – chemical systems*

Relation to CEN/TS 1992-4-1

The principles and requirements of Part 3 of this CEN/TS are additional to those in CEN/TS 1992-4-1, all the clauses and sub-clauses of which also apply to Part 3 unless varied in this Part. Additional information is presented under the relevant clauses/sub-clauses of CEN/TS 1992-4-1. The numbers for the clauses/sub-clauses of Part 3 continue from the number of the last relevant clauses/sub-clauses of Part 1.

The above principles also apply to Figures and Tables in Part 3.

prCEN/TS 1992-4-3:2008 (E)**1 Scope****1.1 General**

1.1.6 This document relies on characteristic resistances and distances which are stated in a European Technical Specification. In minimum the following characteristics should be given in a European Technical Specification as base for the design methods of this CEN/TS.

- $N_{Rk,s,a}$, $N_{Rk,s,c}$, $N_{Rk,s,l}$, $N_{Rk,s,s}$, $V_{Rk,s,s}$, $V_{Rk,s,l}$, $M_{Rk,s,flex}$, $M_{Rk,s}^0$
- $N_{Rk,p}$
- α_{cl} , α_p
- $c_{cr,N}$, $s_{cr,N}$
- $c_{cr,sp}$, $s_{cr,sp}$
- c_{min} , s_{min} , h_{min}
- limitations on concrete strength classes of base material
- k_5
- A_h , b_{ch} , d , h_{ef} , h_{ch} , I_y
- γ_{Mi} partial factors for material see also CEN/TS 1992-4-1:XXXX, clause 4

1.4 Anchor channel loading**1.4.3 Actions not covered**

The following actions are not covered by this CEN/TC:

- shear in the direction of the longitudinal axis of the channel
- fatigue loading
- seismic loading

2 Normative references

This European Standard incorporates by dated or undated reference, provisions from other publications. These normative references are cited at the appropriate places in the text and the publications are listed hereafter. For dated references, subsequent amendments to or revisions of any of these publications apply to this European Standard only when incorporated in it by amendment or revision. For undated references the latest edition of the publication referred to applies.

NOTE The following references to Eurocodes are references to European Standards and European Prestandards. These are the only European documents available at the time of publication of this TS. National documents take precedence until Eurocodes are published as European Standards.

EN 1992-1-1, *Design of concrete structures - Part 1-1: General rules and rules for buildings*

CEN/TS 1992-4-1:XXXX, *Design of fastenings for use in concrete — Part 1: General*

3 Definitions and symbols

The definitions and symbols are given in CEN/TS 1992-4-1.

4 Basis of design

4.5.4 The following assumptions in respect to installation have been made in this CEN/TS. The installation instructions should reflect them:

- 1) The anchor channel should be fixed to the formwork or auxiliary constructions in a way that no movement of the anchor channel will occur during placing of reinforcement or during pouring and compacting of the concrete.
- 2) Requirements for adequate compaction particularly under the head of the anchor and under the channel.
- 3) Requirements for inspection and approval of the correct installation of the anchor channels by appropriately qualified personnel.
- 4) Placing anchor channels by only pushing them into the wet concrete is not allowed.
- 5) It is accepted to vibrate the anchor channels into the wet concrete immediately after pouring under the following conditions:
 - The size and number of fastenings is limited to anchor channels with a length of <1 m if placed by 1 person, so that it can be placed simultaneously during vibrating by the available personnel. Longer channels should be placed by at least 2 persons.
 - The installation is carried out according to a quality system.
 - The anchor channels are not moved after vibrating has been finished.
 - The concrete in the region of the anchor and the anchor channel is properly compacted.

5 Determination of action effects

5.2 Derivation of forces acting on anchor channels

5.2.1 General

5.2.1.6 The distribution of tension loads acting on the channel to the anchors may be calculated using a beam on elastic support (anchors) with a partial restraint of the channel ends as statical system. The resulting anchor forces depend significantly on the assumed anchor stiffness and degree of restraint. For shear loads the load distribution is also influenced by the pressure distribution in the contact zone between channel and concrete.

5.2.1.7 As a simplification for anchor channels with two anchors the loads on the anchors may be calculated assuming a simply supported beam with a span length equal to the anchor spacing.

5.2.1.8 For anchor channels with more than two anchors as an alternative in the following the triangular load distribution method to calculate the distribution of tension and shear loads to the anchors is introduced.

prCEN/TS 1992-4-3:2008 (E)

5.2.1.9 In the case of shear loads, this CEN/TS covers only shear loads acting on the channel perpendicular to its longitudinal axis.

5.2.2 Tension loads

5.2.2.1 This clause supersedes CEN/TS 1992-4-1:XXXX, 5.5.2.

5.2.2.2 The tension forces in each anchor due to a tension load acting on the channel are calculated according to Equation (1), which assumes a linear load distribution over the influence length l_i and takes into account the condition of equilibrium. The influence length l_i shall be calculated according to Equation (3). An example for the calculation of the forces acting on the anchors is given in Figure 1.

$$N_{Ed,i}^a = k \cdot A_i' \cdot N_{Ed} \quad (1)$$

with

A_i' ordinate at the position of the anchor i of a triangle with the unit height at the position of load N and the base length $2l_i$

$$k = \frac{1}{\sum_{i=1}^n A_i'} \quad (2)$$

$$l_i = 13 \cdot I_y^{0,05} \cdot s^{0,5} \geq s \quad [\text{mm}] \quad (3)$$

n number of anchors on the channel within the influence length l_i to either side of the applied load N_{Ed} (see Figure 1)

I_y moment of inertia of the channel [mm^4], see Figure 3.2

s anchor spacing [mm]

The moment of inertia of the channel should be taken from the relevant European Technical Specification.

If several tension loads are acting on the channel a linear superimposition of the anchor forces for all loads should be assumed.

If the exact position of the load on the channel is not known, the most unfavourable loading position should be assumed for each failure mode (e.g. load acting over an anchor for the case of failure of an anchor by steel rupture or pull-out and load acting between anchors in the case of bending failure of the channel).

The bending moment in the channel due to tension loads acting on the channel may be calculated assuming a simply supported single span beam with a span length equal to the anchor spacing.

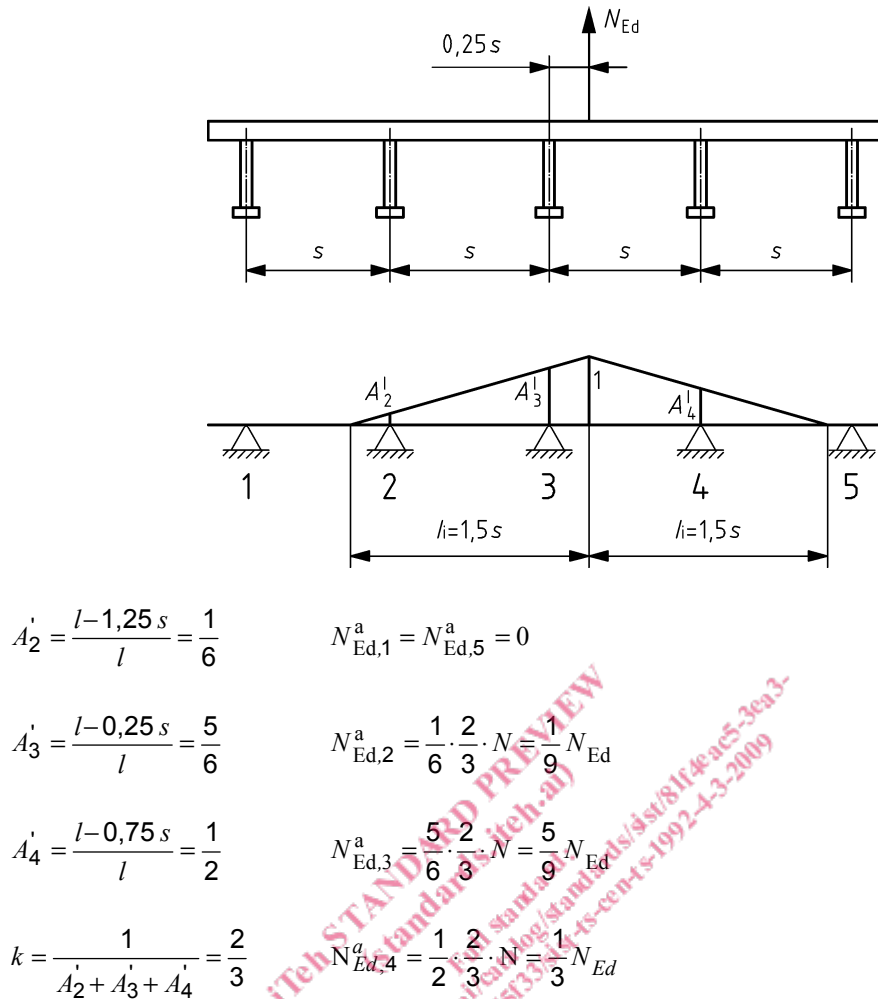

Figure 1 — Example for the calculation of anchor forces according to the triangular load distribution method for an anchor channel with 5 anchors - the influence length is assumed as $l_i = 1,5s$

NOTE The assumption of a simply supported beam to calculate the moments is a simplification which neglects the influence of partial end restraints, continuous beam action for channels with more than 2 anchors and catenary action after yielding of the channel. The characteristic values of the moments of the resistance given in the European Technical Specification take these effects into account. They may be larger than the plastic moment, calculated with the dimensions of the channel and nominal yield strength of the steel.

5.2.3 Shear loads

5.2.3.1 Section 5.2.3.2 supersedes CEN/TS 1992-4-1:xxxx, 5.2.3.1. The provisions given in CEN/TS 1992-4-1:xxxx, 5.2.3.2 and 5.2.3.3 should be used to determine whether a shear load acts with or without a lever arm on the special screw.

5.2.3.2 The shear forces of each anchor due to a shear load acting on the channel perpendicular to its longitudinal axis may be calculated as described in 5.2.2.

NOTE Shear loads applied perpendicular to anchor channels are transferred by compression stresses in the interface between channel and concrete mainly directly into the concrete and a small share to the anchors via bending of the anchor channel. In addition for reasons of equilibrium the anchors are stressed by tension forces. In the approach presented above it is assumed that shear forces are transferred by bending of the channel to the anchors and by the anchors into the concrete. This simplified approach has been chosen to allow for simple interaction between tension and shear forces acting on the channel.

prCEN/TS 1992-4-3:2008 (E)

5.3 Tension forces in a supplementary reinforcement

5.3.3 Tension loads

The design forces $N_{ED, re}$ in the supplementary reinforcement should be calculated using the design load on the anchor.

5.3.4 Shear loads

The design tension force $N_{ED, re}$ in the supplementary reinforcement caused by the design shear force V_{Ed} acting on a fixture is given by Equation (4).

$$N_{ED, re} = V_{Ed} \left(\frac{e_s}{z} + 1 \right) \quad (4)$$

with (see Figure 2):

e_s distance between reinforcement and shear force acting on the anchor channel

z internal lever arm of the concrete member

$$\approx 0,85 h'$$

$$\approx 0,85 \cdot (h - h_{ch} - 0,5d_s)$$

$$h' \leq \min \begin{cases} 2h_{ef} \\ 2c_1 \end{cases}$$

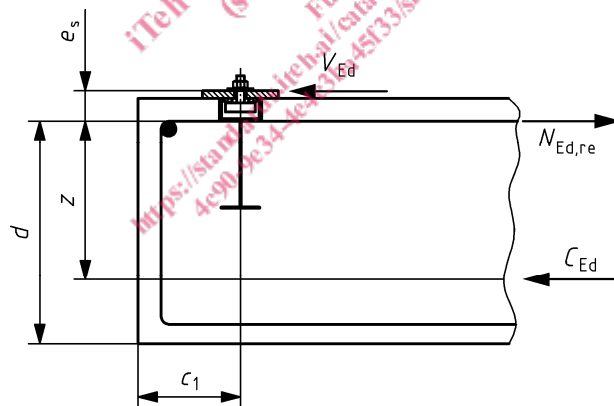

Figure 2 — Surface reinforcement to take up shear forces — detailing of reinforcement

If the supplementary reinforcement is not arranged in the direction of the shear force then this must be taken into account in the calculation of the design tension force of the reinforcement.

In the case of different shear forces on the anchors of the anchor channel, Equation (4) should be solved for the shear load V_{Ed}^h of the most loaded anchor channel resulting in $N_{ED, re}^h$.