



SLOVENSKI STANDARD

SIST EN 480-11:2005

01-december-2005

Nadomešča:
SIST EN 480-11:2002

**Kemijski dodatki za beton, malto in injekcijsko maso – Preskusne metode – 11.
del: Ugotavljanje značilnosti zračnih por v strjenem betonu**

Admixtures for concrete, mortar and grout - Test methods - Part 11: Determination of air void characteristics in hardened concrete

Zusatzmittel für Beton, Mörtel und Einpressmörtel - Prüfverfahren - Teil 11: Bestimmung von Luftporenkennwerten in Festbeton

Adjuvants pour bétons, mortiers et coulis - Méthodes d'essai - Partie 11: Détermination des caractéristiques des vides d'air dans le béton durci

Ta slovenski standard je istoveten z: EN 480-11:2005

ICS:

91.100.10	Cement. Mavec. Apno. Malta	Cement. Gypsum. Lime. Mortar
91.100.30	Beton in betonski izdelki	Concrete and concrete products

SIST EN 480-11:2005 en

iTeh STANDARD PREVIEW
(standards.iteh.ai)

[SIST EN 480-11:2005](#)

<https://standards.iteh.ai/catalog/standards/sist/f737b3e7-654c-4bd7-9398-ac63a447f9a9/sist-en-480-11-2005>

EUROPEAN STANDARD

EN 480-11

NORME EUROPÉENNE

EUROPÄISCHE NORM

September 2005

ICS 91.100.30

Supersedes EN 480-11:1998

English Version

Admixtures for concrete, mortar and grout - Test methods - Part 11: Determination of air void characteristics in hardened concrete

Adjuvants pour bétons, mortiers et coulis - Méthodes
d'essai -Partie 11: Détermination des caractéristiques des
vides d'air dans le béton durci

Zusatzmittel für Beton, Mörtel und Einpressmörtel -
Prüfverfahren - Teil 11: Bestimmung von
Luftporenkennwerten in Festbeton

This European Standard was approved by CEN on 28 July 2005.

CEN members are bound to comply with the CEN/CENELEC Internal Regulations which stipulate the conditions for giving this European Standard the status of a national standard without any alteration. Up-to-date lists and bibliographical references concerning such national standards may be obtained on application to the Central Secretariat or to any CEN member.

This European Standard exists in three official versions (English, French, German). A version in any other language made by translation under the responsibility of a CEN member into its own language and notified to the Central Secretariat has the same status as the official versions.

CEN members are the national standards bodies of Austria, Belgium, Cyprus, Czech Republic, Denmark, Estonia, Finland, France, Germany, Greece, Hungary, Iceland, Ireland, Italy, Latvia, Lithuania, Luxembourg, Malta, Netherlands, Norway, Poland, Portugal, Slovakia, Slovenia, Spain, Sweden, Switzerland and United Kingdom.

<https://standards.iteh.ai/catalog/standards/sist/f737b3e7-654c-4bd7-9398-ac63a447f9a9/sist-en-480-11-2005>



EUROPEAN COMMITTEE FOR STANDARDIZATION
COMITÉ EUROPÉEN DE NORMALISATION
EUROPÄISCHES KOMITEE FÜR NORMUNG

Management Centre: rue de Stassart, 36 B-1050 Brussels

Contents

	Page
Foreword	3
1 Scope	4
2 Normative references	4
3 Terms and definitions	4
4 Principle	5
5 Equipment	6
5.1 General	6
5.2 Specimen preparation	6
5.3 Microscopical analysis	6
6 Specimen production and preparation	7
6.1 Specimen production	7
6.2 Preparation of test surface	7
7 Microscopic procedure	8
7.1 Basic procedure	8
7.2 Values recorded	9
8 Calculations	10
8.1 Data obtained	10
8.2 Total traverse length	10
8.3 Total air content	10
8.4 Total number of chords measured	10
8.5 Specific surface of the air	11
8.6 Paste: air ratio	11
8.7 Spacing factor	11
8.8 Micro-air content	11
8.9 Air void distribution	11
9 Test report	13
Annex A (informative) Theoretical basis of calculation involved in Table 1	15
Annex B (informative) Worked example of the calculation of air void distribution	18

Foreword

This European Standard (EN 480-11:2005) has been prepared by Technical Committee CEN/TC 104 "Concrete and related products", the secretariat of which is held by DIN.

This European Standard shall be given the status of a national standard, either by publication of an identical text or by endorsement, at the latest by March 2006, and conflicting national standards shall be withdrawn at the latest by March 2006.

This document is part of the series EN 480 "Admixtures for concrete, mortar and grout – Test methods" which comprises the following

Part 1 *Reference concrete and reference mortar for testing*

Part 2 *Determination of setting time*

Part 4 *Determination of bleeding of concrete*

Part 5 *Determination of capillary absorption*

Part 6 *Infrared analysis*

Part 8 *Determination of the conventional dry material content*

Part 10 *Determination of water soluble chloride content*

Part 11 *Determination of air void characteristics in hardened concrete*

Part 12 *Determination of the alkali content of admixtures*

Part 13 *Reference masonry mortar for testing mortar admixtures*

Part 14 *Admixtures for concrete, mortar and grout - Test methods - Part 14: Measurement of corrosion susceptibility of reinforcing steel in concrete - Potentiostatic electro-chemical test method*¹⁾

This document is applicable together with the other standards of the EN 480 series.

This document supersedes EN 480-11:1998.

According to the CEN/CENELEC Internal Regulations, the national standards organizations of the following countries are bound to implement this European Standard: Austria, Belgium, Cyprus, Czech Republic, Denmark, Estonia, Finland, France, Germany, Greece, Hungary, Iceland, Ireland, Italy, Latvia, Lithuania, Luxembourg, Malta, Netherlands, Norway, Poland, Portugal, Slovakia, Slovenia, Spain, Sweden, Switzerland and United Kingdom.

1) This part is under preparation

EN 480-11:2005 (E)**1 Scope**

This document describes a test method for determination of the air-void structure in a hardened concrete sample which contains entrained air. The air-void structure is described by means of the following parameters, which are defined in Clause 3.

- i) Total air content
- ii) Specific surface of air void system
- iii) Spacing factor
- iv) Air-void size distribution
- v) Micro air content

The method as described is only suitable for use on hardened concrete specimens where the original mix proportions of the concrete are accurately known and the specimen is representative of these mix proportions. This will generally be the case only where the concrete concerned is produced in a laboratory.

2 Normative references

The following referenced documents are indispensable for the application of this document. For dated references, only the edition cited applies. For undated references, the latest edition of the referenced document (including any amendments) applies.

EN 480-1, *Admixtures for concrete, mortar and grout – Test methods – Part 1: Reference concrete and reference mortar for testing*;
[SIST EN 480-11:2005](https://standards.iteh.ai/catalog/standards/sist/1737b3e7-654c-4bd7-9398-)

<https://standards.iteh.ai/catalog/standards/sist/1737b3e7-654c-4bd7-9398->

EN 934-2, *Admixtures for concrete, mortar and grout – Part 2: Concrete admixtures – Definitions, requirements, conformity, marking and labelling*

ISO 1920-3, *Testing of concrete - Part 3: Making and curing test specimens*

3 Terms and definitions

For the purposes of this European Standard, the following terms and definitions apply.

3.1**air void**

space enclosed by the cement paste that was filled with air or other gas prior to the setting of the paste. This does not refer to voids of submicroscopic dimensions, such as the porosity inherent in a hydrated cement paste. For the purposes of this test method, all voids within the cement paste are considered that are visible at the test magnification with an intercepted chord length of up to 4 mm, other than obvious cracks

3.2**total air content *A***

proportion of the total volume of the concrete that is air voids; expressed as a percentage by volume

3.3**paste content *P***

proportion of the total volume of the concrete that is hardened cement paste, expressed as a percentage by volume. This is the sum of the proportional volumes of cement, mixing water and any admixtures present. For the purposes of this test method it is calculated from the batch weights of the test concrete.

3.4**specific surface of air void system α**

calculated parameter representing the total surface area of the air voids divided by their volume; units are mm^{-1} . The calculation method used is based on the average chord length and is valid for any system of spherical voids

3.5**spacing factor**

calculated parameter related to the maximum distance of any point in the cement paste from the periphery of an air void, measured through the cement paste; units are mm. The calculation of this parameter assumes that all air voids present are of uniform size and are evenly distributed through the cement paste such that the model system has the same total volume and surface area as the real system

NOTE This model is an approximation; the value obtained is probably larger than the actual value.

3.6**air-void distribution**

set of calculated values of the number and/or volume of air voids of various diameters within the hardened cement paste

NOTE The model used for this calculation assumes that only voids having diameters of certain discrete values are present. This model will therefore lie between the real case and the single diameter model that is used in the calculation of the spacing factor. A graphical representation of the distribution can be obtained by plotting the volume of air attributable to each size of void, either as a volume percentage of the cement paste or as a proportion of the total air content.

3.7**micro air content A_{300}**

calculated parameter representing the air content attributed to air voids of 0,3 mm (300 μm) diameter or less. The value for this parameter is obtained during the calculation of the air void distribution

3.8**traverse line**

One of a series of lines across the polished specimen face traced by the relative motion of the microscope and specimen during the test

3.9**length of traverse T_{tot}**

total distance traversed across the surface of the specimens during the test measurement. It is made up of two parts, the total traverse across the surface on solid phases, T_s , and across air voids, T_a , in each case the units are mm

3.10**chord length l**

distance along the traverse line across an air void, units are μm

3.11**chord length classification**

chord lengths across individual air voids are classified into classes based on the length of the chord. The total number of chords in any particular class, i , is designated by C_i . in 8.9 and Table 1 contain details of the boundary values for the classes

4 Principle

Hardened samples of air-entrained concrete are sectioned perpendicular to the original free upper surface to produce specimens for analysis. These specimens are then ground and polished to produce a smooth flat surface finish suitable for microscopic investigation.

EN 480-11:2005 (E)

The air void structure is examined by scanning along a series of traverse lines running parallel to the original free upper surface. The number of air voids intersected by the traverse lines are recorded, as are the individual chord lengths of the traverse across the air voids.

A mathematical analysis of the recorded data then allows a description of the air void system in terms of the required parameters.

Other methods of air void analysis such as the point count method may be used provided that they can be shown to give essentially the same results for the air void parameters required as the method described herein. In the case of dispute the method described in this document shall be used.

5 Equipment**5.1 General**

The following list of equipment has been found suitable for this test. Other apparatus may be used if it can be shown to produce satisfactory results. Not all the equipment may be required for individual test measurements.

5.2 Specimen preparation

- a) Diamond saw;
- b) Grinding machine. One or more instruments able to provide a finished surface of the required quality. These include instruments with a cast iron disc, usually with a minimum diameter of 400 mm, used in conjunction with silicon carbide powder of various grain sizes (typically 120, 60, 30, 16 and 12 μm) or instruments with special grinding discs of the varying grain sizes;
- c) Refrigerator and oven;
- d) Various chemicals for treatment of the polished surface, including; glycerol, stamp ink (matt or dull black, not water soluble), zinc paste and gypsum powder (grain size $\leq 3 \mu\text{m}$).

5.3 Microscopical analysis

- a) A motorised or hand operated cross traverse table. This consists of a platform, on which the specimen rests, which is mounted on lead screws by means of which it can be moved smoothly in two perpendicular directions. One lead screw is required for movement in a direction perpendicular to and two lead screws for movement parallel to the original upper surface. The lead screws should be capable of providing a measure of the total distance travelled to an accuracy of 1 %;
- b) Lighting equipment;
- c) A means of recording the traverse distances and the total number of air voids traversed, divided into classes based on the individual chord lengths;
- d) Stereoscopic microscope, magnification $(100 \pm 10) \times$. The instrument used must be capable of providing the necessary resolution to classify the chords measured into classes as detailed in section 7.2. Other forms of imaging may be used, such as a television camera mounted on the microscope with linked monitor. In these cases the image used for measurements shall be selected so as to produce results for voids counted which are consistent with those produced using direct visual examination through a microscope.

NOTE Use of imaging systems of other magnification may lead to differences in the diameter of the smallest visible voids. These may lead to counting variations and different values for calculated parameters.

6 Specimen production and preparation

6.1 Specimen production

Two samples, of minimum dimension 150 mm, shall be cast from the concrete under investigation. For testing admixtures in accordance with EN 934-2 the concrete shall conform with EN 480-1. Suitable sample geometries include 150 mm cubes or 150 mm diameter cylinders. Manufacture and curing of the samples shall conform with ISO 1920-3.

After the concrete has been cured for a minimum of 7 days, a specimen approximately 100 mm wide by 150 mm high by 20 mm thick shall be cut from the approximate centre of each sample, such that the four cut surfaces are perpendicular to the sample face that was uppermost during manufacture, see Figure 1. One of the largest faces of each specimen is used, after preparation, for microscopic examination.

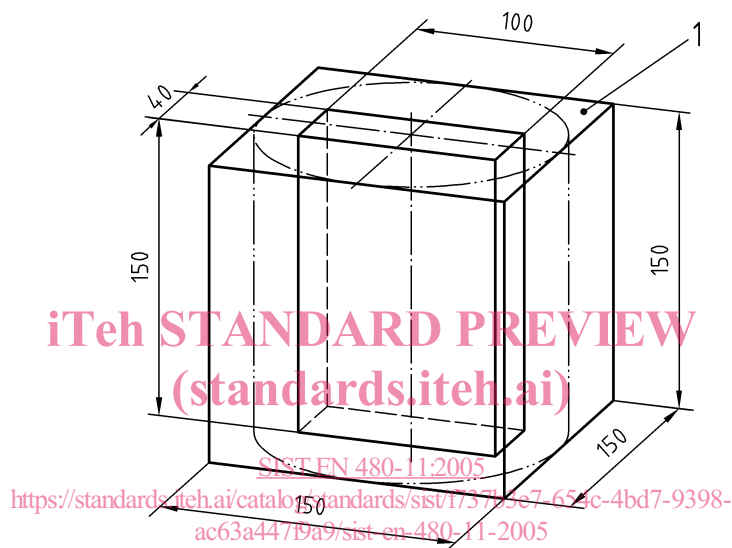

Key

- 1 Upper face during manufacture (original free upper surface)

Figure 1 — Production of 150 mm x 100 mm x 40 mm specimen from 150 mm sample (approximate dimensions)

6.2 Preparation of test surface

The intended test surfaces, one for each specimen, shall be wet ground until they are flat.

After wet grinding, a finely lapped finish to the test surface shall be produced. When this is complete the test surface shall be cleaned to remove any residues.

NOTE The time required for wet grinding depends on the equipment used and will take approximately 5 min. During this procedure, care should be taken to ensure that the test surface and the opposite face of the specimen are as plane parallel as possible.

The exact procedure used will depend on the equipment available. The purpose of the lapping procedure is to produce a surface suitable for microscopic examination of the air void structure within the concrete. A suitable surface should have a matt sheen when dry and have no noticeable relief between the paste and aggregate surface. The edges of voids should be sharp, and should not be broken or rounded. Care should be taken at all stages of the grinding and lapping processes to ensure that voids do not become clogged with grinding residues.

EN 480-11:2005 (E)

After the fine lapping is complete, the test surfaces should be cleaned to remove any residues. Suitable methods are to use water and compressed air or a suitable fine brush. Care should be taken during the cleaning process to ensure that the edges of the voids are not damaged. This may be of particular importance if ultrasonic cleansing is used.

Reproducible results can be expected only with careful and appropriate fine lapping and cleaning of the test surfaces.

The specimen surface can be treated to produce a better contrast between the air-voids and the cement paste, should this be required by the intended measurement procedure. It is likely that this will be necessary if automatic procedures are to be used. This can be done by first applying ink to the surface of the specimen from a stamp pad or roller. Care should be taken to prevent the ink from sinking into the air-voids. The specimen is then placed in an oven at 50 °C for 4 h. It is then covered with zinc paste and refrigerated before any excess zinc paste is removed. Finally, the surface is covered with fine gypsum powder which is pressed into the zinc paste filled air-voids. The excess gypsum powder is then removed with a scraper.

7 Microscopic procedure**7.1 Basic procedure**

The specimens are placed on the cross-traverse table so that the traverse lines which are to be followed run parallel to the original free upper surface of the specimen.

A minimum traverse distance of 1200 mm is required for each specimen, giving a minimum total of 2400 mm per test. A number of traverses across the specimen face are made to give the required total distance. As it is often difficult to ensure a perfect surface finish to the very edge of a specimen, care shall be taken to ensure that any damaged area is not included in the traverse length. The traverse lines shall be laid out as follows, see also Figure 2.

- SIST EN 480-11:2005
- a) Four traverse lines are made in the upper region of the surface, across its width. The uppermost line should be approximately 6 mm from the upper edge of the specimen and subsequent lines should be spaced by approximately 6 mm from each other;
 - b) A further four traverse lines are made in the lower region of the surface. The lowest line should be approximately 6 mm from the lower edge of the specimen and subsequent lines should be spaced by approximately 6 mm from each other;
 - c) Further traverse lines are laid out in the central region of the surface, spaced by approximately 6 mm from each other, so as to produce the total traverse distance required. A minimum of four traverse lines will be required in this area, more may be needed to provide the required minimum traverse lengths if damaged areas exist on the surface.

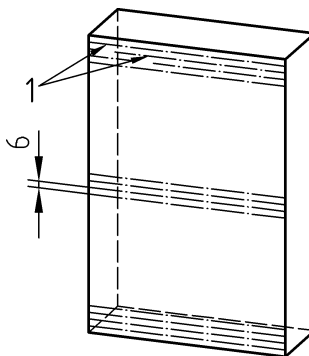
**Key**

- 1 Traverse lines at 6 mm separation

Figure 2 — Distribution of traverse lines on the test surface

7.2 Values recorded

The surface shall be viewed through the microscope at a magnification of $(100 \pm 10) \times$. The magnification shall not be changed during the period of measurement. The sample is viewed along the lines of traverse described in 7.1. During the traverse, the two lead screws for movement parallel to the original free upper surface shall be used to provide separate measures of the total distances traversed across;

- a) the solid portions of the specimen surface, T_s ;
- b) any voids intercepted, T_a ;

The sum of these two values gives the total traverse distance, T_{tot} ;

If the pore size distribution and/or the content of micro pores has to be determined then, in addition, a separate tally of the number of chords produced by the intersection of the traverse lines with air voids shall be kept as follows:

- c) estimated length of each chord to the nearest $5 \mu\text{m}$;
- d) total number of chords in each class, using the class limits given in Table 1 and further explained in 8.9.

This procedure provides a subdivision of all chords occurring into 28 classes of different lengths. This classification can then be used to calculate a corresponding air void distribution. In the counting procedure, include all chords which are across visible voids in the hardened cement paste with a chord length on the traverse line of between 0 and $4000 \mu\text{m}$. The only exceptions to this being obvious cracks.

If, in spite of careful grinding, the edges of voids are broken and such a breakage lies on a traverse then the completed circular section shall be used as the basis for determining the chord length. The method of determining the relevant chord length is shown in Figure 3.²⁾

2) Automatic imaging systems will not be able to make this correction and this may lead to errors in the final analysis.