**Starch and derived products — Heavy
metals content —**

Part 2:

**Determination of mercury content by atomic
absorption spectrometry**

iTeh STANDARD PREVIEW
*Amidons, fécules et produits dérivés — Teneur en métaux lourds —
Partie 2: Détermination de la teneur en mercure par spectrométrie
d'absorption atomique*

ISO 11212-2:1997

<https://standards.iteh.ai/catalog/standards/sist/044030e0-83e9-405e-b95a-ade25d5dd56/iso-11212-2-1997>



Foreword

ISO (the International Organization for Standardization) is a worldwide federation of national standards bodies (ISO member bodies). The work of preparing International Standards is normally carried out through ISO technical committees. Each member body interested in a subject for which a technical committee has been established has the right to be represented on that committee. International organizations, governmental and non-governmental, in liaison with ISO, also take part in the work. ISO collaborates closely with the International Electrotechnical Commission (IEC) on all matters of electrotechnical standardization.

Draft International Standards adopted by the technical committees are circulated to the member bodies for voting. Publication as an International Standard requires approval by at least 75 % of the member bodies casting a vote.

International Standard ISO 11212-2 was prepared by Technical Committee ISO/TC 93, *Starch (including derivatives and by-products)*.

ISO 11212 consists of the following parts, under the general title *Starch and derived products — Heavy metals content*:

- *Part 1: Determination of arsenic content by atomic absorption spectrometry*
- *Part 2: Determination of mercury content by atomic absorption spectrometry*
- *Part 3: Determination of lead content by atomic absorption spectrometry with electrothermal atomization*
- *Part 4: Determination of cadmium content by atomic absorption spectrometry with electrothermal atomization*

Annex A of this part of ISO 11212 is for information only.

© ISO 1997

All rights reserved. Unless otherwise specified, no part of this publication may be reproduced or utilized in any form or by any means, electronic or mechanical, including photocopying and microfilm, without permission in writing from the publisher.

International Organization for Standardization
Case postale 56 • CH-1211 Genève 20 • Switzerland
Internet central@iso.ch
X.400 c=ch; a=400net; p=iso; o=isocs; s=central

Printed in Switzerland

Starch and derived products — Heavy metals content —

Part 2:

Determination of mercury content by atomic absorption spectrometry

1 Scope

This part of ISO 11212 specifies a method for the determination of the mercury content of starch, including derivatives and by-products, by atomic absorption spectrometry with cold-vapour generation.

The cold-vapour generators currently available use very different techniques; it is thus impossible to propose a comprehensive method likely to ensure the attainment of satisfactory results on all types of apparatus. Each analyst should therefore optimize the conditions of use of his/her own apparatus on the basis of general or particular instructions.

iteh STANDARD PREVIEW
(standards.iteh.ai)

2 Definition

[ISO 11212-2:1997](https://standards.iteh.ai/catalog/standards/sist/044030e0-83e9-405e-b95a-2d925151156/iso-11212-2-1997)

[https://standards.iteh.ai/catalog/standards/sist/044030e0-83e9-405e-b95a-](https://standards.iteh.ai/catalog/standards/sist/044030e0-83e9-405e-b95a-2d925151156/iso-11212-2-1997)

[2d925151156/iso-11212-2-1997](https://standards.iteh.ai/catalog/standards/sist/044030e0-83e9-405e-b95a-2d925151156/iso-11212-2-1997)
For the purposes of this part of ISO 11212, the following definition applies.

2.1 mercury content: Quantity of mercury determined in accordance with the conditions specified in this method and expressed as mercury (Hg), in micrograms per kilogram of the product as received.

3 Principle

Wet digestion of the organic matrix. Reduction of mercury (Hg^{2+}) to metallic mercury by hydrogen resulting from the action of sodium borohydride (or tin(II) chloride) on hydrochloric acid. Entrainment of the mercury vapour by a flow of gas and determination of monoatomic mercury vapour by atomic absorption spectrometry in a quartz cell.

Measurement of the absorbance at a wavelength of 253,7 nm.

Determination of the concentration of mercury in the sample by means of a calibration curve.

4 Reagents

Use only reagents of recognized analytical grade and distilled water or water of equivalent purity.

4.1 Nitric acid ($\rho_{20} = 1,38$ g/ml).

4.2 Hydrogen peroxide, 30 % (V/V) solution.

4.3 Sodium borohydride solution

Prepare a solution at the concentration recommended in the instructions for use of the cold-vapour generator (5.3).

4.4 Tin(II) chloride solution

Prepare a solution at the concentration recommended in the instructions for use of the cold-vapour generator (5.3).

4.5 Hydrochloric acid solution

Prepare a solution at the concentration recommended in the instructions for use of the cold-vapour generator (5.3).

4.6 Mercury standard solution, 1 g/l.

Standard solutions are commercially available at this concentration. These solutions may be prepared by weighing and dissolving the salt or metal of known purity.

4.7 Calibration solutions

Before each series of measurements, prepare from the standard mercury solution (4.6) at least five calibration solutions covering the range of concentrations to be determined. 100 ml of each calibration solution shall contain 7,5 ml of nitric acid (4.1).

5 Apparatus

All the glassware used shall be previously washed by means of suitable products (such as nitric acid) and rinsed with distilled water to eliminate any trace of mercury.

Use ordinary laboratory apparatus and, in particular, the following.

5.1 Digestion apparatus (see figure 1), made of borosilicate glass and consisting of three elements terminating with conical ground joints (5.1.1 to 5.1.3).

5.1.1 Soxhlet extraction tube, of capacity 200 ml, equipped with a stopcock and a lateral tube connected directly to the flask (5.1.3).

5.1.2 Cooling apparatus, 35 cm long, connected to the top of the Soxhlet extraction tube (5.1.1).

5.1.3 Round-bottom flask, of capacity 250 ml, connected to the lower part of Soxhlet extraction tube (5.1.1).

When the stopcock is open, the device is under reflux; when it is closed the Soxhlet extraction tube (5.1.1) retains the condensed water and acid vapours.

5.2 Atomic absorption spectrometer, consisting of five elements (5.2.1 to 5.2.5).

5.2.1 High-resolution monochromator, allowing a 0,2 nm bandwidth slit.

5.2.2 Correcting device for non-specific absorption.

5.2.3 Measuring and photoelectric reception device, with a response time not exceeding about 10 ms.

5.2.4 Detector and signal processing system, allowing recording of the maximum and/or integrated absorbance signal.

5.2.5 Mercury discharge lamp or mercury hollow cathode lamp.

5.3 Generator of cold mercury vapour, allowing the generation of cold mercury vapour as well as its transport to a measuring cell whose wavelength is adapted to the spectrometer, and equipped with an automatic sampling device which is necessary to obtain good repeatability and to reduce the risk of contamination.

5.4 Pipettes and micropipettes, of suitable capacity.

5.5 Analytical balance.

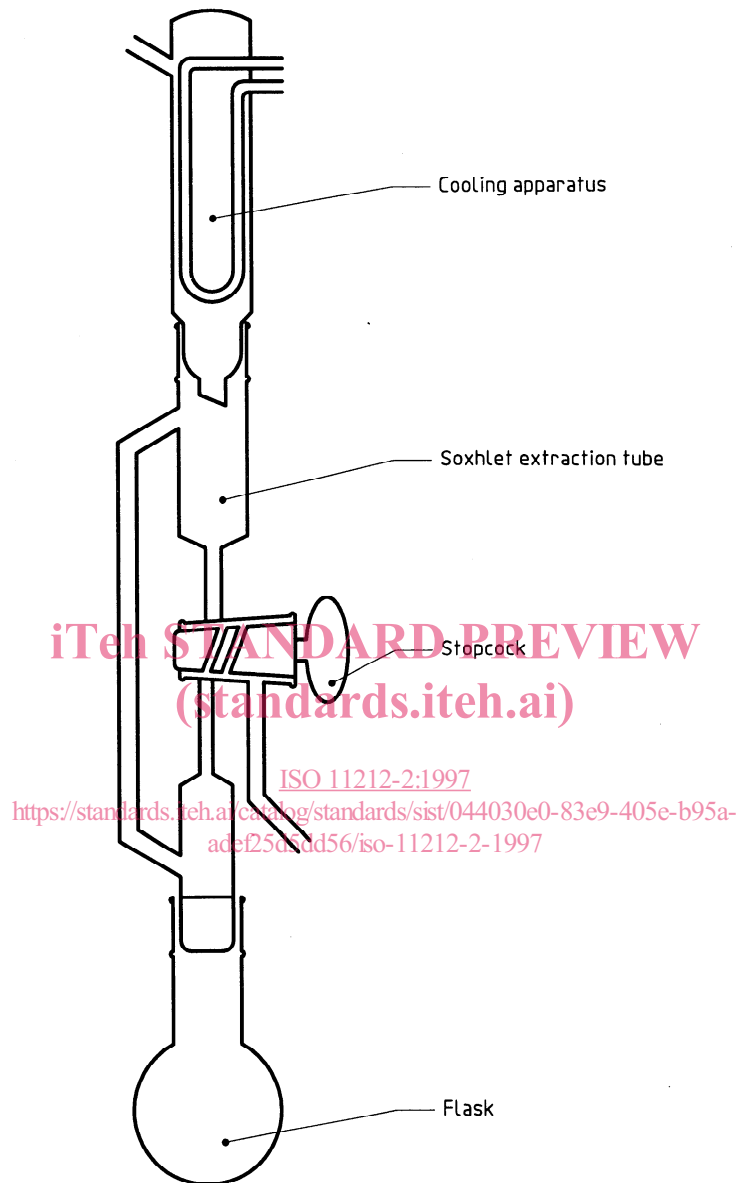

Figure 1 — Digestion apparatus

6 Procedure

WARNING — Mercury is highly toxic and is a very volatile element. It is thus necessary to verify the tightness of the ground joints and of the tap and to avoid any overheating at digestion in order to prevent any loss of mercury vapour.

6.1 Preparation of test sample

Thoroughly homogenize the sample.

6.2 Digestion

Use the digestion apparatus described in 5.1.

Weigh, to the nearest 1 mg, about 5 g of the test sample into the flask (5.1.3). Add 27,5 ml of nitric acid (4.1) and 1 ml of hydrogen peroxide (4.2). Distil under reflux for 4 h leaving the stopcock open. Turn the stopcock off, continue heating and distil until about 20 ml \pm 1 ml of liquid are recovered in the extraction tube (5.1.1). Stop heating and allow the flask to cool. Separate the flask from the extraction tube. Add 20 ml of water to the digested residue in the flask, bring to the boil for a few minutes, stop heating and allow to cool. Transfer the solution to a 100 ml volumetric flask, dilute to the mark with distilled water and stir.

NOTE — To reach the required precision, the tin(II) chloride or the gold amalgam enrichment technique can be used as reducing agent.

6.3 Blank test

Perform digestion under the same conditions as in 6.2, replacing the test portion by 5 ml of water.

6.4 Determination of the calibration curve

Carry out the analysis of the diluted calibration solutions (4.7) with reference to the instructions for use of the cold-vapour generator (5.3) by adding the recommended quantities of tin(II) chloride solution (4.4) and sodium borohydride solution (4.3). Measure the absorbance of each calibration solution at a wavelength of 253,7 nm using the spectrometer (5.2).

Draw the calibration curve by plotting the mercury concentrations of the calibration solutions, expressed in micrograms per litre, as the abscissa against the corresponding values of the signal, read either in maximum absorbance or in integrated absorbance, as the ordinate. The calibration curve shall be periodically checked depending on the length of the series of analyses.

6.5 Determination

ISO 11212-2:1997
<https://standards.iteh.ai/catalog/standards/sist/044030e0-83e9-405e-b95a-ade25d5dd56/iso-11212-2-1997>

Measure the absorbance of the test samples under the same conditions as the calibration solutions and compare the results with the previously plotted calibration curve.

7 Expression of results

With reference to the calibration curve, determine the concentrations corresponding to the signals of the test portion and the blank. The mercury concentration of the sample, w , expressed in micrograms per kilogram of the product as received, is given by the equation:

$$w = \frac{(\rho_1 - \rho_0) \times 100}{m}$$

where

ρ_1 is the numerical value of the mercury concentration, in micrograms per litre, of the test solution (6.2) read from the calibration curve (6.4);

ρ_0 is the numerical value of the mercury concentration, in micrograms per litre, of the blank test solution (6.3) read from the calibration curve (6.4);

m is the numerical value of the mass, in grams, of the test portion (6.2).

NOTE — When strictly following this method, the quantification limit can reach 20 $\mu\text{g}/\text{kg}$.

8 Precision

Details of an interlaboratory test on the precision of the method are summarized in annex A. The values derived from the interlaboratory test may not be applicable to analyte concentration ranges and matrices other than those given in annex A.

8.1 Repeatability

The absolute difference between two independent single test results, obtained using the same method on identical test material in the same laboratory by the same operator using the same equipment within a short interval of time, will not exceed the repeatability limit r deduced from table A.1 in more than 5 % of cases.

8.2 Reproducibility

The absolute difference between two single test results, obtained using the same method on identical test material in different laboratories with different operators using different equipment, will not exceed the reproducibility limit R deduced from table A.1 in more than 5 % of cases.

9 Test report

The test report shall specify:

- the method in accordance with which sampling was carried out, if known;
- the method used;
- the test result(s) obtained; and
- if the repeatability has been checked, the final quoted result obtained.

It shall also mention all operating details not specified in this part of ISO 11212, or regarded as optional, together with details of any incidents which may have influenced the test result(s).

The test report shall include all information necessary for the complete identification of the sample.

Annex A (informative)

Results of interlaboratory test

An interlaboratory test at the international level was carried out by 12 laboratories in 1993. The statistical results indicated in table A.1 were determined in accordance with ISO 5725¹⁾.

Table A.1 — Interlaboratory test on corn starch

| Parameter | Sample ¹⁾ | | |
|--|----------------------|-------|-------|
| | LC | HC | VHC |
| No. of laboratories retained after eliminating outliers | 7 | 8 | 8 |
| No. of outliers (laboratories) | 5 | 5 | 5 |
| No. of accepted results | 28 | 31 | 32 |
| Mean mercury content (µg/kg) | 49,4 | 98,5 | 161,5 |
| Repeatability standard deviation, s_r (µg/kg) | 5,4 | 10,7 | 11,7 |
| Repeatability limit, $r = 2,8 \times s_r$ (µg/kg) | 15,2 | 30,3 | 33,2 |
| Reproducibility standard deviation, s_R (µg/kg) | 18,7 | 43,4 | 71,8 |
| Reproducibility limit, $R = 2,8 \times s_R$ (µg/kg) | 53,0 | 122,9 | 203,2 |
| 1) Corn starch with LC: low content HC: high content VHC: very high content | | | |

ISO 11212-2:1997
<https://standards.iteh.ai/catalog/standards/sis/044030e0-83e9-403e-b95a-ade25d5dd56/iso-11212-2-1997>

1) ISO 5725:1986, *Precision of test methods — Determination of repeatability and reproducibility for a standard test method by inter-laboratory tests* (now withdrawn), was used to obtain the precision data.

iTeh STANDARD PREVIEW
This page intentionally left blank
(standards.iteh.ai)

ISO 11212-2:1997

<https://standards.iteh.ai/catalog/standards/sist/044030e0-83e9-405e-b95a-ade25d5dd56/iso-11212-2-1997>